

dynaco

PAS-3X

SERIAL NUMBER

This number must be mentioned in all communications concerning this equipment.

STEREO PREAMPLIFIER

INSTRUCTIONS FOR ASSEMBLY AND OPERATION



dynaco inc.

COLES ROAD & CAMDEN AVENUE / POST OFFICE BOX 88
BLACKWOOD, N. J. 08012, U.S.A.

Bob01605@aol.com

SPECIFICATIONS

- Inputs:** 3 stereo low level: RIAA phono, NAB tape head (7½"), "Special" (optional second phono, microphone, etc.). 4 stereo high level: FM-AM, FM-Multiplex, Spare, Tape.
- Outputs:** Tape output. Audio output.
- Controls:** Selector, Volume, Balance, Blend, Individual Treble and Bass for each channel, Tape Monitor, Loudness, Scratch Filter, Power.
- Tone Control Range:** ± 14 db at 20,000 cycles. ± 20 db at 20 cycles.
- Distortion:** Less than 0.05% intermodulation at 2 volts (sufficient output to drive any amplifier). Distortion does not increase at lower settings of volume control. Harmonic distortion below the measurement capabilities of regular commercial grade test equipment.
- Response:** ± .5 db 10 cps to 40 kc. Response not affected by position of volume control.
- Transient performance:** Passes square waves without ringing and with minimum deformation from 20 cps to 20,000 cps. No overshoot or bounce on pulse type signals. Instantaneous recovery from overload.
- Hum and noise:** 2 microvolt equivalent noise on RIAA. 74 db below level of 10 millivolt signal.
- Gain:** 60 db at 1,000 cycles on RIAA; 60 db on Tape Head; 20 db on Radio and other high level inputs.
- Impedances:** Output impedance 1,000 ohms; terminating impedance 100,000 ohms or higher. Low level input impedance 50,000 ohms; high level input impedance 250,000 ohms.
- Tubes:** 4 12AX7/ECC-83; 1 12X4; 1 selenium stack.

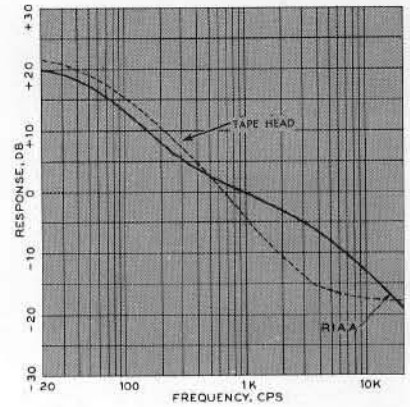

Equalization.

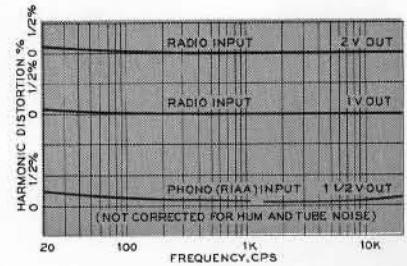

Harmonic distortion percentage.

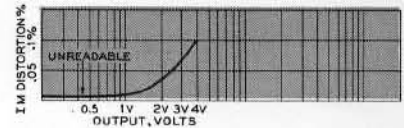

IM distortion.

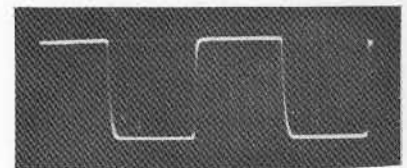

10 KC square wave from Dynakit (below) is much like original (above).

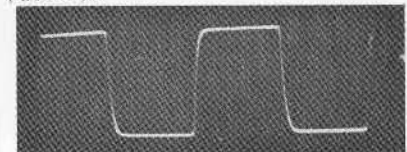

INSTRUCTIONS FOR ASSEMBLY OF THE DYNAKIT PAS-3X PREAMPLIFIER

DESCRIPTION

The Dynaco PAS-3X stereo preamplifier is a versatile two channel control center which permits either monophonic or stereophonic reproduction from any program source (records, tape, microphone, radio tuner) with any modern amplifier. This preamplifier design is most renowned for its low noise and low distortion, and it provides striking simplicity of operation while retaining full flexibility for the enthusiast's subtle adjustments.

The circuit of the Dynakit is unique, and is a subject of patent applications. All stages are enclosed in feedback loops and are adjusted for an absolute minimum of distortion and noise. Signals going through the preamplifier are not audibly changed by passage through this instrument, proving that its characteristics are ideal, since the goal of any high fidelity equipment is amplification and reproduction of the original signal without change.

The preamplifier essentially has five parts. The power supply is one part and is common to both channels. This power supply contains a full-wave rectifier and a power transformer. A separate rectifying system is used to provide direct current to heat the filaments of the tubes. This is one of the reasons why there is practically no hum in the Dynakit.

The remaining four sections have several functions. There are equalizer-amplifier stages: high-gain circuits designed to bring up the level of such devices as magnetic phonograph cartridges and at the same time to impose the proper playback characteristic on the frequency response. There is one of these stages for left and another for the right stereophonic channels. The remaining two sections consist of the two amplifying-tone control stages, one for left and one for right channel. High level signals such as those from a radio tuner are fed through these stages, and the functions of volume control, tone control, and similar control functions are accomplished at these points in the circuit.

Although the left and right channels are essentially independent, some control functions are common to both channels to facilitate use. For example, one volume control controls the volume of both channels simultaneously. A balance control is used to adjust the relative levels between the channels. A blend control, a unique Dynaco feature, permits controllable reduction of the stereophonic effect in order to eliminate any possibility of a "hole in the middle" which characterizes some types of stereophonic source material. The selector switch also controls both channels simultaneously as do the subsidiary switching functions of scratch filter, loudness, etc. However, the tone controls for each channel are independent, because it has been found that each channel must individually be adjusted for tonal balance because of differences between loudspeakers and room acoustics, which require such balancing in order to obtain optimum stereophonic effect.

Some of the hidden attributes of your Dynakit lie in the unusual circuit arrangement in which there is no possibility of overloading of inputs regardless of the output signal of the program source, nor is there any frequency discrimination as the volume is lowered. These common ailments of other designs have been completely eliminated in the Dynakit circuit. Some other built in advantages which are not obvious are covered in the following section which concerns the application of the Dynakit.

USING YOUR PREAMPLIFIER

Your Dynakit preamplifier has been designed to give you long time performance, ease of operation, and complete flexibility to handle all control requirements of both simple and elaborate Hi Fi systems. It serves as a central point of the entire Hi Fi system to which everything else connects. On the rear of the Dynakit are all of the input and output connections. These come in two groups. The upper row is for the left or "A" channel. The lower row is for the right or "B" channel. If your Dynakit is used monophonically only, you can use the upper row alone, although in some extremely complex monophonic system it might be desirable to use the lower row as a duplicate set of inputs, doubling the number of possible signal sources. However, since there are inputs for seven sources on either row, these should take care of practically all requirements.

Two of the sockets for each channel are for outputs. One of these, marked "audio output," is connected to your power amplifier or amplifiers. The other, marked "tape out," goes into the high level signal input of a tape recorder if one is used in the system. The input marked "radio" on the tape recorder can be used for this function. When using this connection, any signals going through the preamplifier can be recorded by turning on the tape recorder while the normal playing and operation of the preamplifier are not affected.

There are a large number of inputs for each channel. The three low level inputs (which include necessary equalization facilities for low level source material) are for magnetic phonograph cartridge, tape head (in a tape deck which does not have its own electronic amplification), and "special." This special input can be used for a variety of functions including an extra phonograph, microphone, a different equalization characteristic, etc.

There are four high level inputs for each channel. One of these is for radio, one for multiplex, one for tape recorder output (for tape recorders which have their own built in preamplifiers), and a spare which can be used for TV sets or other high level input sources. If you do not have a multiplex adapter or FM tuner with built in multiplex output, the multiplex input can be used as an auxiliary high level input source.

Also on the back of your preamplifier are four AC outlets. Two of these are switched on and off with the front panel "on-off" switch, and two are on all of the time. Switched outlets can be used to power your amplifier and tuner, and these will go on and off when you switch the preamplifier on and off. The un-switched outlets should be used for devices like the record player or tape recorder in which mechanical switch-off at the apparatus is desirable.

The line cord comes out of the back panel, and this should not be plugged in until you are familiar with the function of all of the controls. When it is plugged in it should be in an AC power source only. This preamplifier will not work on DC current.

The front panel contains all of the operating controls and switches. These will be discussed in turn.

Selector Switch

The selector switch is used to pick the program source to which you want to listen. When switching from one input to another this switch takes care of both channels simultane-

ously and also includes the necessary changes in equalization for the different program material. Below this switch is a small slide switch labeled TAPE-INPUT. This is part of the selection function. When this switch is on "input" (this is the normal position), all program material to which the selector switch is set comes through the entire preamplifier. When this switch is on "tape," the only signal which can be heard through the preamplifier is a signal which is applied to the tape input socket—normally the output of a tape playback machine. However, while the switch is on "tape," the signal source to which the selector switch is set will be available at the tape output socket on the rear. The reason for this arrangement is that a tape machine which has an *extra* head for monitor purposes can be recording the program material selected by the selector switch while flipping the TAPE-INPUT switch back and forth permits the user to compare the sound source material with the sound from the tape machine—enabling an A-B comparison of the recording process.

Volume Control

The output of both channels is controlled simultaneously by the volume control. This specially chosen control gives close tracking of the two stereo channels so that the program material will remain in balance over most of the range of the volume control. The taper rate of this control is chosen to provide a slow increase in volume over the first half of rotation and a more rapid volume increase above 12 o'clock. This enables most satisfactory operation with both low and high efficiency speakers. Below the volume control is the loudness switch which permits you to add loudness compensation at lower level settings of the volume control. Because the ear is not as sensitive to extreme frequencies at low levels of sound, when music is played softly, it sounds thinner. The loudness compensation gives increased bass below 400 cycles and effectively moves the listener toward the front of the concert hall. When the switch is off, there is no frequency discrimination in the volume control circuit, and this will be preferred by the high fidelity purist, but most listeners will find that its use in moderation will add enjoyment for listening at low levels. This sonic correction does not add boom or muddiness to the reproduction.

Blend Switch (Stereo-Mono Selector)

This switch fulfills the function of blending the program material. At extreme counter-clockwise position the two stereo channels are completely independent. As the control is rotated clockwise, the stereo effect is progressively eliminated. When the control passes the center position to the point marked "A + B," the two stereo channels are being added together. This is the proper position for playing monophonic records as it is desirable to combine the sound channels for maximum fidelity when playing monophonic discs. The two positions labeled "A" and "B" are positions in which monophonic sound sources are sent through both speaker channels. When on "A," the left input source appears through both; when on "B," the right input source appears through both loudspeakers. For example, if an AM-FM tuner of the stereo type is plugged into the radio sockets in the rear, the "A" position of this switch will give FM reproduction through both speakers, and the "B" position will give AM reproduction through both speakers. It is also practical by using this switch to use any other pair of inputs as separate monophonic sources. For example, it is possible to use the "special" input as a microphone source on the "A" channel and a monophonic cartridge input on the "B" channel.

Balance Control

Below the stereo-monophonic switch is a control which adjusts the balance between the two channels. In center position equal signals go through both channels. Rotation to one side or the other reduces the signal in one channel. This is a full range control which will permit cutting out sound from one channel completely. The need for balancing exists because some program sources are not balanced accurately, and it is also possible that the two loudspeakers being used have different efficiencies. Thus a certain amount of balancing is semi-permanent in nature while other balancing functions vary from program source to program source. Thus it is frequently necessary to rebalance when changing records or when switching the selector switch.

Tone Controls

There are individual bass and treble controls for each channel. These are of the type in which the center setting is flat response without frequency discrimination. These controls increase or decrease the signal level at frequency extremes depending on whether they are rotated clockwise or counter-clockwise. Normal "flat" use of these controls is in the center position with variation made to correct the tonal balance to please the taste of the listener. It is recommended that these should be left centered and adjustments made with reference to the flat setting rather than having the user fall in the habit of preserving a setting which offers a large amount of tonal correction all the time. The reference point should always be the center setting which gives no frequency discrimination. It is practical also to use the tone controls to correct for record compensation characteristics of records of old vintage which do not follow the RIAA standard playback characteristics.

Below the tone controls are located the scratch filter and power switch. The scratch filter, when "on," gives response essentially flat to 7,000 cycles with a rapid roll-off thereafter. This is a unique configuration which removes high frequency distortion and noise with practically no effect on the music. Since the effect is so high in the audible range, the action of the control will hardly be noticeable unless there is a significant amount of high frequency component present. However, where there is a great deal of hiss or high frequency distortion, it can be reduced significantly by proper use of the scratch filter.

GENERAL WIRING PRACTICE

Assembly of the Dynakit preamplifier is quite simple compared to general kit assembly requirements. This is true because all critical parts of the Dynakit are factory assembled for you on the printed circuit assemblies. Other parts are put out in the open through a free and uncluttered layout so there is easy accessibility for wiring or trouble shooting purposes. Construction of your Dynakit should not take more than about eight hours because of these simplifications.

Upon opening your kit, check the components with the parts list. Familiarize yourself with the components; they can be identified by comparison with the pictorial diagram and by specified color coding. Proper color coding will be mentioned for each resistor as it is used.

Tools required for easy assembly of your Dynakit are soldering iron (small tip) or soldering gun, long nose pliers, screwdriver, and wire cutters. Although not essential, a low cost wire stripper and cutter of the type which can be purchased for less than \$1.00 will greatly facilitate cutting and stripping the various leads in the kit.

Good soldering technique is valuable in obtaining satisfactory results from any electronic equipment. ALL SOLDERING MUST BE DONE WITH ROSIN CORE SOLDER. There is no warranty on any equipment in which acid core solder has been used. Make sure that the solder used is plainly marked "Rosin Core." If you have solder on hand the origin of which is doubtful it is wise to obtain new 50/50 or 60/40 rosin core solder. Whenever soldering is required, the assembly instructions specify it by "(S)." If this symbol is not shown after a connection is specified, it indicates that further connections will be made at that point before soldering.

Soldering is accomplished by heating the joint with the iron until solder is hot enough to flow when touched to the joint. It is not desirable to feed the solder to the iron. It should be fed to the junction of iron and joint. After the solder flows, the iron should be held in place for a few seconds and removed when it is seen that the solder has contacted both parts of the connection—the lug and the wire to which it is connected. It should not show a ball of solder but a smooth transition from solder to component lead.

Before applying solder the joint should be clean and the lead should be crimped in place so as to have mechanical security. It is not necessary to wrap leads around contacts many times. A single turn and pinching together with long nose pliers is suitable. After soldering, there should be no play at the joint if the lead is wiggled with a pair of pliers. It is practical to do all soldering with a pencil type iron of low wattage rating. A small tip is extremely useful when working in a confined space. If a soldering gun is used, it should be used with discretion since the amount of heat available is far more than required for soldering light wires.

Component leads should be trimmed as they are used; the length should be such that the proper connection can be made from point to point without strain on lugs or components. Care should be exercised not to allow wires to touch one another unless they are actually connected to the same point.

The instructions which follow have been arranged for simplified procedure in which the work can be done without interference between the various portions of the wiring. It is recommended that the instructions be followed on a step by step basis, checking off each stage as it is completed. The pictorial diagrams should be used for reference and all connections checked against these before going on to the next stage. If the wiring is done methodically and each step checked carefully, your preamplifier should work without difficulty as soon as it is completed.

Mechanical assembly of front panel subassembly

Place the front panel in front of you so that you are looking at the inside. Note that the pictorial diagram identifies the parts which are fitted in the various holes. These parts are referred to by abbreviations—BC, for Balance Control, LT for Left Treble, etc.

- 1 () Mount the pilot light socket, PL, with #4 hardware, (the smallest size of screws, nuts, and lockwashers supplied). Insert the #4 screw in the dimpled hole, place the socket mounting flange over the screw, then a lockwasher, and fasten securely with a #4 nut.
- 2 () All four of the slide switches which mount on the bottom of the panel have threaded holes in their mounting flanges so that lockwashers and nuts are unnecessary. Mount the AC power switch, PS, (the one with two connecting lugs). Note the location of

the connecting lugs of this switch in the pictorial. Fasten with #4 screws.

- 3 () Mount the scratch filter switch, FS. The remaining slide switches are identical with six lugs in each. Fasten with #4 screws.
- 4 () Mount the loudness switch, LS. Fasten with #4 screws.
- 5 () Mount the tape monitor switch, MS. Fasten with #4 screws.
- 6 () There are two 750,000 ohm potentiometers, these are the left bass control, LB, and the right bass control, RB. For ease of identification when wiring you may mark the backs of these and other controls with their symbols. Place a $\frac{3}{8}$ lockwasher on the shaft of LB and insert the shaft in the proper hole. Fasten with a $\frac{3}{8}$ nut.
- 7 () Mount bass control, RB. Use a lockwasher on the shaft, insert in hole, and fasten with a $\frac{3}{8}$ nut.
- 8 () There are two 400,000 ohm potentiometers; these are the left treble control, LT, and the right treble control, RT. These may also be marked for identification later. Place a $\frac{3}{8}$ lockwasher on the shaft of LT and mount it. Fasten with a $\frac{3}{8}$ nut.
- 9 () Place a $\frac{3}{8}$ lockwasher on the shaft of RT and mount in the proper hole. Fasten with a $\frac{3}{8}$ nut.
Be sure that all potentiometers are mounted with their lugs facing as indicated in the pictorial.
- 10 () Mount the dual 750,000 ohm balance control BC. Use a $\frac{3}{8}$ lockwasher and nut.
- 11 () Mount the blend switch, BS, (switch with one wafer). Use a $\frac{3}{8}$ lockwasher and nut. Mount the switch so that the red dot on the frame is at the top.
- 12 () Mount the dual 250,000 ohm volume control VC, using a $\frac{3}{8}$ lockwasher and nut.
The selector switch, SS, (with three wafers) will be mounted later after it is wired.

Wiring front panel subassembly

In the following procedure, a number of wires will be connected only at one end. The other ends of these will be connected later when the sub-assembly is connected to the main chassis.

REMINDER—All lengths of wire specified include $\frac{1}{4}$ " at each end from which the insulation should be stripped unless other instructions are given for the amount of stripping.

- 1 () Twist together a pair of $5\frac{1}{2}$ " black wires. From one pair of ends connect one to PL lug #1 (S). Connect the other to PL lug #2 (S).
- 2 () Twist together a 10" black wire and a 14" black wire so that one pair of ends are even. From the even pair of ends connect one to PS lug #1; connect the other to PS lug #2.
- 3 () Trim each lead of the .02 disc capacitor to $\frac{3}{4}$ ", and slide a $\frac{1}{2}$ " piece of insulating sleeving over each. Connect one lead to PS lug #1 (S). Connect the other lead to PS lug #2 (S). Position the capacitor under the switch.
- 4 () Strip one end of a 2" black wire $\frac{5}{8}$ ". Feed the longer bare end through FS lug #4 and connect to FS lug #1.

- 5() Feed one end of a 3.3 megohm (orange-orange-green) resistor through FS lug #5 and connect to FS lug #4 (S). Connect the other end of the resistor to FS lug #6. Leads of resistors should be trimmed to size as they are used to make proper and neat connections.
 - 6() Connect one end of a 5" red wire to FS lug #6 (S).
 - 7() Feed one end of a 3.3 megohm (orange-orange-green) resistor through FS lug #2 and connect to FS lug #5 (S). Connect the other end to FS lug #3. Solder at FS lug #2.
 - 8() Connect one end of a 4½" green wire to FS lug #3 (S).
 - 9() Connect one end of a .002 mfd tubular capacitor to RT lug #1 (S). Connect the other end to RB lug #1.
 - 10() Connect one end of a .002 mfd tubular capacitor to LT lug #1 (S). Connect the other end to LB lug #1.
 - 11() Connect one end of a .02 mfd tubular capacitor to LT lug #3 (S). Connect the other end to FS lug #1.
 - 12() Connect one end of a .02 mfd tubular capacitor to RT lug #3 (S). Connect the other end to FS lug #1 (S).
 - 13() Connect one end of a 2½" red wire to RB lug #1 (S).
 - 14() Connect one end of a 3¾" red wire to RT lug #2 (S).
 - 15() Connect one end of a 3" red wire to RB lug #2 (S).
 - 16() Cut the (+) lead of a 1 mfd capacitor to ¾". Connect this (+) end to RB lug #3 (S).
 - 17() Connect one end of a 3¼" green wire to LB lug #1 (S).
 - 18() Connect one end of a 4½" green wire to LT lug #2 (S).
 - 19() Connect one end of a 3¼" green wire to LB lug #2 (S).
 - 20() Cut the (+) lead of the remaining 1 mfd capacitor to ¾". Connect this (+) end to LB lug #3 (S).
- NOTE:** The lugs of the switch BS are counted *counter clockwise* starting at the top left lug when *viewed from the rear*.
- 21() Connect one end of a 47,000 ohm (yellow-violet-orange) resistor to BS lug #12 (S). Connect the other end to BS lug #10.
 - 22() Connect one end of a 6½" green wire to BS lug #10 (S). Connect the other end to MS lug #2 (S).
 - 23() Connect one end of a 2" black wire to BS lug #11 (S). Connect the other end to BS lug #6.
 - 24() Connect one end of a 47,000 ohm (yellow-violet-orange) resistor to BS lug #9. Connect the other end to BS lug #7 (S).
 - 25() Connect one end of a 7½" red wire to BS lug #9 (S). Connect the other end to MS lug #5 (S).
 - 26() Connect one end of a 1½" red wire to BS lug #8. Connect the other end to BS lug #4.
 - 27() Connect one end of a 33,000 ohm (orange-orange-orange) resistor to BS lug #4 (S). Connect the other end to BS lug #3.
 - 28() Connect one end of a 68,000 ohm (blue-grey-orange) resistor to BS lug #3 (S). Connect the other end to BS lug #2 (S).
 - 29() Connect one end of a 3" green wire to BS lug #1 (S). Connect the other end to BC lug #4 (S).
 - 30() Connect one end of a 1½" black wire to BS lug #6 (S). Connect the other end to BC lug #1.
 - 31() Connect one end of a 2½" red wire to BS lug #8 (S). Connect the other end to BC lug #3 (S).
 - 32() Connect one end of a 2" red wire to BC lug #2 (S). Connect the other end to VC lug #1 (S).
 - 33() Connect one end of a 8" red wire to VC lug #2 (S).
 - 34() Connect one end of a 4" green wire to VC lug #6 (S).
 - 35() Connect one end of a 2" black wire to BC lug #1 (S). Connect the other end to VC lug #7.
 - 36() Connect one end of a 2¼" green wire to BC lug #5 (S). Connect the other end to VC lug #5 (S).
 - 37() Feed one end of a 4700 ohm (yellow-violet-red) resistor through VC lug #7 and connect to VC lug #3. Connect the other end to LS lug #1.
 - 38() Connect one end of a 4700 ohm (yellow-violet-red) resistor to BC lug #6. Connect the other end to LS lug #4.
 - 39() Connect one end of a 3½" black wire to VC lug #3 (S).
 - 40() Connect one end of a 2" black wire to BC lug #6 (S). Connect the other end to VC lug #7 (S).
 - 41() Connect one end of a .1 mfd tubular capacitor to LS lug #4 (S). Use sleeving on bare wire to prevent contact with adjacent parts. Connect the other end to VC lug #4.
 - 42() Connect one end of a 3½" red wire to VC lug #4 (S). Connect the other end to LS lug #5 (S).
 - 43() Connect one end of a .1 mfd tubular capacitor to LS lug #1 (S). Connect the other end to VC lug #8.
 - 44() Connect one end of a 3" green wire to VC lug #8 (S). Connect the other end to LS lug #2 (S).
 - 45() Connect one end of a 12" red wire to MS lug #6 (S).
 - 46() Connect one end of a 13" green wire to MS lug #3 (S).

Main chassis mechanical assembly

Consult the pictorial for location of components.

- 1() Mount the power transformer (PA-211 or PA-522) in the right rear corner of the chassis. Use #8 screws, lockwashers, and nuts. The screws are inserted from the bottom of the chassis with the screw heads below the chassis. Note that the red and red/yellow transformer wires go through the hole nearest the side of the chassis and the black wires go through the hole nearer the rear edge of the chassis.
- 2() Mount the seven pin socket in the next group of holes toward the front. The socket is mounted from the bottom of the chassis and fastened with #4 hardware. Instead of a lockwasher use the single ground lug on the front mounting screw but use a lockwasher on the other screw. Observe that the open space between pins #1 and #7 should face the cutout for the filter capacitor.
- 3() Mount the quadruple section filter capacitor (in a can) in the special cutout just in front of the tube socket. Note the symbols at the base of each connecting lug; be sure these are located according to the pictorial. Fasten the capacitor can by giving each mounting tab a half twist with your pliers.
- 4() Insert the long #8 screw in the small hole near the rear center of the chassis from the bottom. Fasten it

in place with a #8 lockwasher and nut. Place the two 2000 mfd capacitors on either side of the screw, paying particular attention to the location of the positive and negative symbols on each one as indicated in the pictorial diagram.

Place the capacitor bracket on the screw over the capacitors and then place the selenium rectifier on the screw so that the yellow connecting lug faces to the rear and the red and black lugs face the power transformer. Now place the one lug terminal on the screw and fasten the whole assembly with another #8 lockwasher and nut.

- 5() Mount the printed circuit board PC-5 at the large cutout in the chassis. The board is mounted below the chassis. Note that most of the eyelets are at the forward edge. Use #4 hardware.
- 6() The printed circuit board PC-6 is mounted at the other large cutout, also below the chassis, and with #4 hardware. Be sure to orient the board properly, as indicated by the pictorial diagrams.
- 7() With four #6 sheet metal screws fasten the front panel sub-assembly to the main chassis.

Wiring the main chassis

The eyelets on the printed circuit boards already have solder in them. Each eyelet has a number which will be referred to in these instructions. Before making a connection to the board, "tin" the stripped portion of the wire to be connected by heating it with the soldering iron and touching solder to it. To solder to the eyelet, heat the eyelet with the iron, insert the wire in the eyelet when the solder flows, remove the iron, and allow a few seconds for the solder to set. Although the metal eyelet does protect the printed wiring from overheating, a small iron should be used to avoid excessive heat. Where the wire connects to an eyelet above the board, tilt chassis on end; heat the eyelet below the board while inserting tinned wire end from above. When the wire connects to a terminal above the board, the top of the terminal should be heated.

- 1() Twist together the two red transformer leads. Connect one red lead to pin #1 of the seven pin socket V1 (S). Connect the other red lead to pin #6 of V1 (S).
- 2() Connect the red-yellow lead to a ground lug (mounting tab) of the quad filter capacitor. (See pictorial)
- 3() Connect one of the black twisted pair of wires from PL lugs #1 and #2 to pin #3 of V1. Connect the other of the pair to pin #4 of V1.
- 4() Twist together a pair of 9" black wires. Connect one end of one wire to pin #3 of V1 (S). Connect one end of the other wire to pin #4 of V1 (S). Feed the twisted pair through the hole between the transformer and the 2000 mfd capacitors. Connect one of the pair to the lug terminal which is mounted above the selenium rectifier. Connect the other of the pair to the yellow lug of the rectifier.
- 5() Twist together the blue transformer wires. Connect one of the blue wires to the yellow lug of the rectifier (S). Connect the other blue wire to the lug terminal on top of the selenium rectifier.
- 6() Twist together a pair of 6" black wires. Connect one end of one wire to the red lug of the selenium rectifier; connect one end of the other wire to the black

lug of the rectifier. Feed this pair of wires through the hole in the chassis. Connect one wire to printed circuit board PC-5 eyelet #18 (S). Connect the other wire to PC-5 eyelet #19 (S).

- 7() Cut a piece of black wire and a piece of red wire each 8½" long. Twist these together. Connect one end of the red wire to the red lug on the selenium rectifier and one end of the black wire to the black lug on the rectifier. Feed this pair through the hole in the chassis. Connect the red wire to printed circuit board PC-6 eyelet #15 (S). Connect the black wire to PC-6 eyelet #14 (S).
 - 8() Connect the negative (-) lead of the 2000 mfd capacitor nearest the rear of the chassis to the black lug of the rectifier (S). Connect the positive (+) lead of the other capacitor to the red lug of the rectifier (S). Connect both the remaining positive lead of the one capacitor and the negative lead of the other, to the one lug terminal at the top of the rectifier (S).
 - 9() Connect one end of a 1½" black wire to pin #7 of V1 (S). Connect the other end to lug #1 of the quad-rect section capacitor.
 - 10() Connect one end of a 10,000 ohm (brown-black-orange) resistor to lug #1 of the quad capacitor (S). Connect the other end to lug #2 of the quad capacitor.
 - 11() Connect one end of a 10,000 ohm (brown-black-orange) resistor to lug #2 of the quad capacitor. Connect the other end to lug #3 of the quad filter.
 - 12() Connect one end of a 47,000 ohm (yellow-violet-orange) resistor to lug #2 of the quad capacitor (S). Connect the other end to lug #4 of the capacitor. Use sleeving on the bare wires.
 - 13() Connect one end of a 4" black wire to lug #3 of the quad capacitor (S). Connect the other end to eyelet #16 of PC-5 (S).
 - 14() Connect one end of a 14" black wire to lug #4 of the quad capacitor (S). Connect the other end to eyelet #16 of PC-6 (S).
 - 15() Connect one end of an 8½" black wire to the ground lug which is one of the mounting prongs of the quad capacitor (S) (See pictorial) and connect the other end to eyelet #1 of PC-5 (S).
 - 16() Connect one end of a 12" black wire to the ground lug of the quad capacitor. Connect the other end to eyelet #4 of PC-6 (S). (See pictorial)
 - 17() Connect one end of a 14½" black wire to the same ground lug as in step 16 (S). Connect the other end to eyelet #11 of PC-6 (S).
 - 18() Connect one end of a 1½" black wire to the ground lug at the tube socket mounting screw (S). Connect the other end to the same capacitor ground lug as in step #2 (S).
- The following steps up to step 35 all refer to PC-5.
- 19() Connect the black wire from VC 3 to eyelet #1 (S). This is the second wire to eyelet #1.
 - 20() Connect the green wire from VC 6 to eyelet #2 (S).
 - 21() Connect the green wire from LT 2 to eyelet #3 (S).
 - 22() Connect the green wire from LB 1 to eyelet #4 (S).
 - 23() Trim the remaining lead of the capacitor from LB 3 as required, and connect it to the top of eyelet #5 (S). Be sure it clears adjacent circuitry.

- 24 () Connect the green wire from LB 2 to eyelet #6 (S).
- 25 () Connect the green wire from FS 3 to eyelet #15 (S).
- 26 () Connect the black wire from FS 4 to eyelet #8 (S)
- 27 () Dress the red wire from VC 2 close against the front of the chassis. Connect the red wire from VC 2 to eyelet #9 (S).
- 28 () Connect the red wire from RT 2 to eyelet #10 (S).
- 29 () Connect the red wire from RB 1 to eyelet #11 (S).
- 30 () Trim the remaining lead of the capacitor from RB 3 as required, and connect it to the *top* of eyelet #12 (S). Be sure it clears adjacent circuitry.
- 31 () Connect the red wire from RB 2 to eyelet #13 (S).
- 32 () Connect the red wire from FS 6 to eyelet #17 (S).
- 33 () Connect one end of a 12" red wire to eyelet #14 (S). Heat the eyelet from the bottom and insert the wire from the top of PC-5.
- 34 () Connect one end of a 8" green wire to eyelet #7 (S). Heat the eyelet from the bottom and insert the wire from the top.
- 35 () Connect one end of an 8½" black wire to eyelet #1 (S). This wire is to be connected at the top of the board. There are already two wires connected at the bottom of the board. Be careful to see that all three wires are properly soldered.

Back panel mechanical assembly

Place the back panel in front of you so that you are looking at the inside.

- 1 () At the bottom right of the panel there are four groups of holes in a row, each with a rectangular hole and two small round holes. Mount an AC outlet at each of these using #4 hardware.
- 2 () Insert the rubber grommet in the 3/8 hole at the right end of the panel.
- 3 () The multiple input connectors are next; note that each socket has a long center terminal and a short side terminal. The short side terminal is the ground lug. Mount the two four socket connectors in the two right hand cutouts with four sets of #4 hardware each.
- 4 () Mount the two five socket connectors in the remaining cutouts. Note specifically the arrangement of the sockets; the odd side (ground) lug goes to the extreme left. Use #4 hardware. Be sure the sockets do not contact the chassis.

Back panel wiring

The upper row of sockets is the left channel socket group. The lower row is the right channel group.

- 1 () Connect a 2" black wire to the ground (short) lug of left socket #1. Connect the other end to the pair of ground lugs between left sockets #2 and #3 (S).
- 2 () Connect one end of a 2½" black wire to the pair of ground lugs between left sockets #4 and #5 (S). Connect the other end to the pair of ground lugs between left sockets #6 and #7.
- 3 () Connect one end of a 10 ohm (brown-black-black) resistor to the pair of ground lugs between left sockets #6 and #7 (S). Connect the other end to the pair of ground lugs between left sockets #8 and #9.
- 4 () Connect one end of a 510,000 ohm resistor (green-brown-yellow) to the pair of ground lugs between left sockets #8 and #9. Connect the other end to the long lug left socket #9.
- 5 () Strip a 2" piece of wire completely. Connect one end to the ground lugs between left sockets #8 and #9 (S). Connect the other end to the pair of ground lugs between right sockets #8 and #9.
- 6 () Connect one end of a 510,000 ohm (green-brown-yellow) resistor to the ground lugs between right sockets #8 and #9. Connect the other end to the long lug of right socket #9.
- 7 () Connect one end of a 10 ohm (brown-black-black) resistor to the ground lugs between right sockets #8 and #9 (S). Connect the other end to the pair of ground lugs between right sockets #6 and #7.
- 8 () Connect one end of a 2½" black wire to the ground lugs between right sockets #6 and #7 (S). Connect the other end to the pair of ground lugs between right sockets #4 and #5 (S).
- 9 () Connect one end of a 2" black wire to the ground lugs between right sockets #2 and #3 (S). Connect the other end to the ground lug of right socket #1.
- 10 () Connect one end of a 3" black wire to lug A of AC outlet #1 (S). Connect the other end to lug A of outlet #2.
- 11 () Connect one end of a 3" black wire to lug B of outlet #1 (S). Connect the other end to lug B of outlet #2.
- 12 () Connect one end of a 3" black wire to lug B of outlet #2. Connect the other end to lug B of outlet #3.
- 13 () Connect one end of a 3" black wire to lug B of outlet #3 (S). Connect the other end to lug B of outlet #4.
- 14 () Connect one end of a 3" black wire to lug A of outlet #3 (S). Connect the other end to lug A of outlet #4.

Selector switch subassembly

Note that there is a red dot on the forward part of the frame of the selector switch. This is between lugs #1 and #12. The lugs are numbered from the red dot in *clockwise* fashion when viewing the switch from the *front*. This is true for all three wafers; the front wafer (closest to the shaft) will be called wafer A, the middle wafer B, and the rear wafer C. Where a pair of lugs is at one position, the wire is passed through both, and they are wired as if they are a single lug.

- 1 () Connect one end of a 27,000 ohm (red-violet-orange) resistor to lug #2 of wafer B. Connect the other end to lug #10 of wafer B (S).
- 2 () Connect one end of a 750 PF (or MMF) capacitor to lug #2 wafer B. Connect the other end to lug #11 wafer B (S).
- 3 () Connect one end of a 27,000 ohm (red-violet-orange) resistor to wafer B lug #4 (S). Connect the other end to wafer B lug #8.
- 4 () Connect one end of a 750 PF (or MMF) capacitor to wafer B lug #5 (S). Connect the other end to wafer B lug #8.
- 5 () Connect one end of a 1½" red wire to wafer A lug #4 (S). Connect the other end to wafer A lug #7.

- 6() Connect one end of a 1" red wire to wafer A lug #10. Connect the other end to wafer A lug #12 (S).
- 7() Connect one end of a 1½" green wire to wafer C lug #4 (S). Connect the other end to wafer C lug #7.
- 8() Connect one end of a 1" green wire to wafer C lug #10. Connect the other end to wafer C lug #12 (S).
- 9() Connect one end of a 12" red wire to wafer A lug #1.
- 10() Connect one end of a 3¾" red wire to wafer A lug #1 (S).
- 11() Connect one end of a 3" red wire to wafer A lug #2 (S).
- 12() Connect one end of a 9½" black wire to wafer A lug #3.
- 13() Connect one end of a 2¾" black wire to wafer A lug #3 (S).
- 14() Connect one end of a 2" red wire to wafer A lug #5 (S).
- 15() Connect one end of a 7½" red wire to wafer A lug #6 (S).
- 16() Connect one end of a 7" red wire to wafer A lug #7 (S).
- 17() Connect one end of a 7" red wire to wafer A lug #8 (S).
- 18() Connect one end of a 9" red wire to wafer A lug #9 (S).
- 19() Connect one end of a 9½" red wire to wafer A lug #10 (S).
- 20() Connect one end of a 10½" red wire to wafer A lug #11 (S).
- 21() Connect one end of a 3½" red wire to wafer B lug #2 (S).
- 22() Connect one end of a 4" red wire to wafer B lug #12 (S).
- 23() Connect one end of a 3" green wire to wafer B lug #6 (S).
- 24() Connect one end of a 4¼" green wire to wafer B lug #8 (S).
- 25() Connect one end of a 7" green wire to wafer C lug #1.
- 26() Connect one end of a 7" green wire to wafer C lug #1 (S).
- 27() Connect one end of a 2¾" green wire to wafer C lug #2 (S).
- 28() Connect one end of a 8" black wire to wafer C lug #3.
- 29() Connect one end of a 2¾" black wire to wafer C lug #3 (S).
- 30() Connect one end of a 2¼" green wire to wafer C lug #5 (S).
- 31() Connect one end of a 6" green wire to wafer C lug #6 (S).
- 32() Connect one end of a 6" green wire to wafer C lug #7 (S).
- 33() Connect one end of a 5½" green wire to wafer C lug #8 (S).

- 34() Connect one end of a 4½" green wire to wafer C lug #9 (S).
- 35() Connect one end of a 6" green wire to wafer C lug #10 (S).
- 36() Connect one end of a 6½" green wire to wafer C lug #11 (S).

Final assembly

Fasten the back panel assembly to the main chassis with four sheet metal screws.

- 1() Connect the short black wire of the twisted pair from PS #1 and #2 to lug A of AC outlet #4. Connect the long black wire of the pair to lug A of AC outlet #2.
 - 2() Connect one of the black transformer leads to lug A of outlet #4 (S). Connect the other black transformer lead to lug B outlet #4 (S).
- NOTE: If you are using the optional 120/240 volt power transformer PA-522, replace this step with the steps specified on Page 13.
- 3() Install the selector switch SS. Place a ⅜ lockwasher on the shaft, insert in hole SS and fasten with a ⅜ nut. Be sure that the red dot on the frame of the switch is at the top.
 - 4() Connect the short red wire from SS wafer A lug #1 to MS lug #4 (S).
 - 5() Connect the red wire from SS wafer A lug #2 to eyelet #1 of PC-6 (S).
 - 6() Connect the short black wire from SS wafer A lug #3 to eyelet #4 of PC-6 (S) (In addition to the wire already soldered below the board).
 - 7() Connect the red wire from SS wafer A lug #5 to eyelet #6 (S) of PC-6.
 - 8() Connect the red wire from SS wafer A lug #6 to right input socket (long lug) #3 (S).
 - 9() Connect the red wire from SS wafer A lug #7 to right socket (long lug) #2 (S).
 - 10() Connect the red wire from SS wafer A lug #8 to right socket (long lug) #1 (S).
 - 11() Position the long black wire from SS wafer A lug #3 across the rear of the wafer, between the center rotor shaft and the lower spacer. Wrap this wire around the three red wires from lugs #6, #7 and #8, and connect it to the ground (short) lug of right channel input socket #1 (S).
 - 12() Connect the red wire from SS wafer A lug #9 to right socket #4 (S).
 - 13() Connect the red wire from SS wafer A lug #10 to right socket #5 (S).
 - 14() Connect the red wire from SS wafer A lug #11 to right socket #6 (S).
 - 15() Connect the long red wire from SS wafer A lug #1 to right socket #8 (S).
 - 16() Connect the red wire from MS lug #6 to right socket #7 (S).
 - 17() Connect the red wire from PC-5 eyelet #14 (top of board) to right socket #9 (S).
 - 18() Connect the red wire from SS wafer B lug #12 to PC-6 terminal #2 (S). These elevated terminals facilitate lead connections to eyelets which are difficult to reach. For best results, first heat the terminal with the iron, and flow a small quantity of solder into it. Then "tin" the wire end with solder before inserting it into the terminal.

PC-5

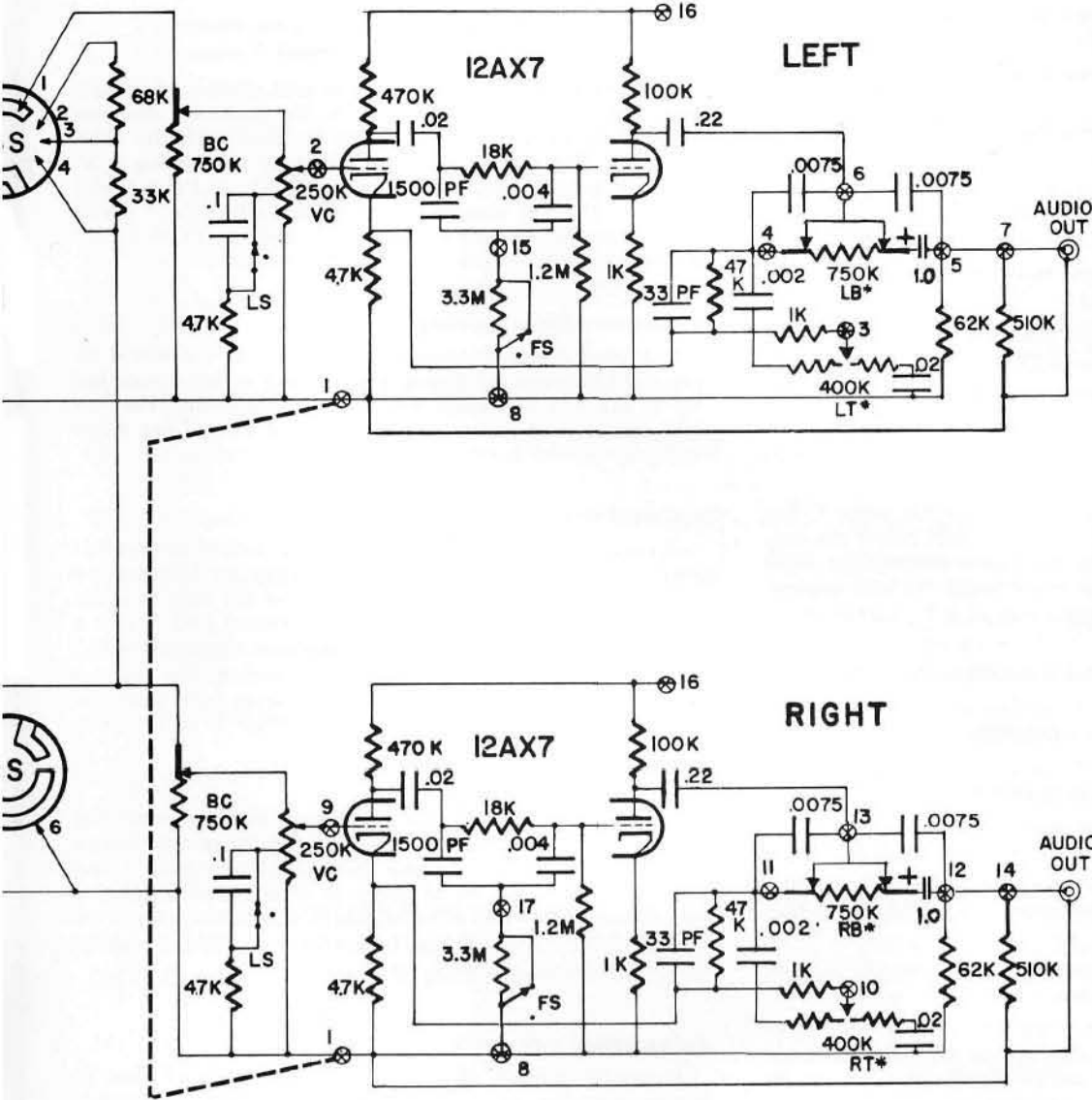

VOLTAGE CHART

Tube pins numbered clockwise viewed from the bottom.

All readings taken from pin to chassis (except #3 and #4 of 12X4) using a vacuum tube voltmeter.

Either tube PC-6

- 1 115 V DC
- 2 0
- 3 .7 V DC
- 4 0
- 5 ± 11 V DC
- 6 135 V DC
- 7 0
- 8 .8 V DC
- 9 ± 5.5 V DC

Either tube PC-5

- 1 175 V DC
- 2 0
- 3 1.45 V DC
- 4 Less than 1 volt
- 5 ± 11 V DC
- 6 200 V DC
- 7 0
- 8 1.25 V DC
- 9 ± 5.5 V DC

12X4

- 1 335 V AC
- 2 0
- 3 10.5 V AC
- 4 10.5 V AC
- 5 0
- 6 335 V AC
- 7 405 V DC

Quad Filter Capacitor

- 405 V DC
- ▲ 355 V DC
- 330 V DC
- 210 V DC

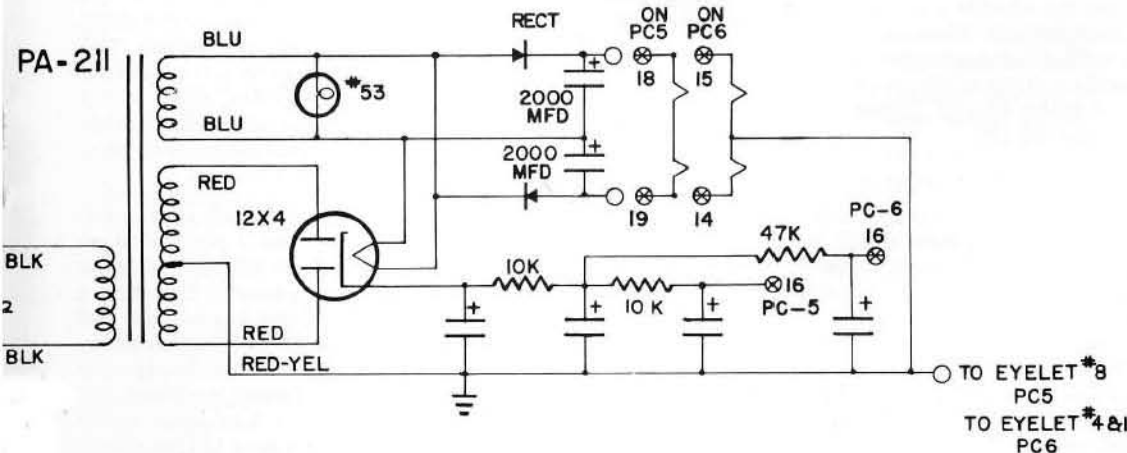

* special potentiometers—patent

- 19() Connect the red wire from SS wafer B lug #2 to PC-6 terminal #3 (S).
- 20() Connect the green wire from SS wafer B lug #6 to PC-6 terminal #8 (S).
- 21() Connect the green wire from SS wafer B lug #8 to PC-6 terminal #9 (S).
- 22() Connect one green wire from SS wafer C lug #1 to MS lug #1 (S).
- 23() Connect the green wire from SS wafer C lug #2 to PC-6 terminal #7 (S).
- 24() Connect the short black wire from wafer C lug #3 to PC-6 eyelet #11 (S) (In addition to the wire already soldered below the board).
- 25() Connect the green wire from SS wafer C lug #5 to eyelet #13 of PC-6 (S).
- 26() Connect the green wire from SS wafer C lug #6 to left socket (long lug) #3 (S).
- 27() Connect the green wire from SS wafer C lug #7 to left socket #2 (S).
- 28() Connect the green wire from SS wafer C lug #8 to left socket #1 (S).
- 29() Position the long black wire from SS wafer C lug #3 across the rear of the wafer, and below the center rotor shaft. Wrap this wire around the three green wires from lugs #6, #7 and #8, and connect it to the ground (short) lug of left channel input socket #1 (S).
- 30() Connect the green wire from SS wafer C lug #9 to left socket #4 (S).
- 31() Connect the green wire from SS wafer C lug #10 to left socket #5 (S).
- 32() Connect the green wire from SS wafer C lug #11 to left socket #6 (S).
- 33() Connect the green wire from SS wafer C lug #1 to left socket #8 (S).
- 34() Connect the green wire from MS lug #3 to left socket #7 (S).
- 35() Connect the green wire from PC-5 eyelet #7 (top of the board) to left socket #9 (S).
- 36() Connect the black wire from PC-5 eyelet #1 (top of the board) to the center of the bare wire between right ground lugs #8 and #9 and left ground lugs #8 and #9 (S).
- 37() Insert the line cord from the outside and pull about seven inches through the grommet. Tie a knot in the cord so that about five inches remains inside the knot. Position the cord under the outlets as shown and connect one end to lug A of outlet #2 (S). Connect the other end to lug B of outlet #2 (S).

"Special" Input

The Special input offers a variety of options which can provide considerable flexibility for the user. If left unwired, the equalization characteristic (augmented by the tone controls) is suitable for 78 rpm records. When wired as indicated below, it can be used for a low level stereo source or one channel can be wired for one monophonic input, and the other channel for a different mono input. Then the "A" and "B" selector function of the stereo-mono (blend) switch enables selection of either source, and the blending function permits limited mixing of the two signals at the audio output.

Please note that each channel can be wired for only one function at a time. If you change from one characteristic to another, be sure that you first remove all special wiring. *Factory assembled preamplifiers are connected for microphone input on both channels.*

a. Microphone (Dynamic or Velocity types)

A microphone requiring standard 50K ohms load impedance may be wired as shown in the pictorial diagram (crystal or ceramic mikes cannot be used with the PAS preamp). The right channel is wired by connecting a 3" red wire from switch wafer B, lug #9 (S), to PC-6 eyelet #5 (S). The left channel is connected with a 3½" green wire from switch wafer B, lug #3 (S) to PC-6 eyelet #12 (S).

b. Magnetic Phono Cartridge

A second magnetic phono cartridge can be connected on the right channel by wiring a short link of wire from lug #9 to lug #11 of switch wafer B (solder both). For the left channel, connect a wire between lug #3 and lug #5 of wafer B (solder both).

c. Crystal or Ceramic Phono Cartridge

A ceramic or crystal cartridge (½ volt output or greater) may be connected by first wiring the input for Microphone as in paragraph "a" above. Then remove the wire to input socket #3 on the back panel of the preamp and solder a 3.3 megohm one-half watt resistor between (in series with) the wire and the long lug of the input socket. The resistor leads should be cut to ½" to avoid excess bare wire. Do this for each channel if a stereo cartridge is to be used.

d. Tape Head

A second 7½" NAB tape head input may be connected by wiring a short link of wire from lug #9 to lug #10 of switch wafer B for the right channel (solder both), and from lug #3 to lug #4 of wafer B (solder both) for the left channel. As there is no standard equalization for 3¾" speed, the tone controls may be needed for optimum results with such tapes.

Completion

Carefully inspect all the wiring to make sure that it agrees with the pictorial diagrams and the photographs. Because the pictorials must be exaggerated for clarity, the photographs best define lead placement. Note particularly the placement of the wires leading the selector switch. The green wires to the rear (C) wafer of the switch should be kept above the chassis and grouped together, and the red wires to the front (A) wafer should be grouped together and kept close to the chassis. Be sure that no twisted pairs of wires are positioned across the circuit boards.

Insert the four 12AX7 tubes into the sockets on the circuit boards. The 12X4 tube goes into the 7 pin socket on the chassis. Install the pilot light. Each rubber foot is installed in a corner hole in the bottom plate by inserting a #6 screw through the foot so that the head is recessed, and securing it with a nut on the inside of the bottom plate. The other two holes in the bottom plate are used only with the brackets for cabinet installations. Install the cover and bottom plate, and secure them with the four sheet metal screws through the sides. Remove the paper backing from the adhesive identification label, and smooth it into position on the bare part of the back panel.

The pilot light jewel should be inserted through the front plate, and secured with the spring clip, which is squeezed open for installation by gripping it with pliers. Install the front plate, and secure it with $\frac{3}{8}$ " nuts on each control. Use care to avoid scratching the front plate.

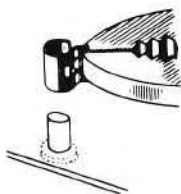

Install the two large knobs on the selector switch and volume control. The set screw tightens onto the flat portion of the switch shaft, and the volume control shaft should be turned fully counter-clockwise and the knob positioned so that its pointer indicates seven o'clock, and the set screw tightened. The small knobs are then installed on the other six control shafts. Rotate the blend switch fully counter-clockwise, and position the knob pointer so that it indicates full stereo (the longest rectangle). The knobs on the balance control and on the four tone controls should be installed so that rotation is symmetrical either side of center. This will provide flat response when the pointer is straight up. Tighten the set screws securely.

INSTALLING YOUR PREAMPLIFIER

Your Dyna preamplifier serves as the control center for the entire music system, and is of a quality level which justifies the finest associated equipment. Be sure it is connected to AC current sources only.

As you have completed it, the PAS-3X is designed to work into power amplifiers with input impedances of 100,000 ohms or higher, requiring between 0.5 and 2.5 volts input for rated output. This includes all of the generally available tube and transistor amplifiers. Those having an input impedance lower than 100,000 ohms will require slight adaptation of the preamplifier, and factory consultation will enable you to secure optimum results.

The position of the Blend Switch (stereo-mono selector) marked with the smallest rectangle provides the exact amount of blending to achieve maximum separation when a center channel speaker is used in accordance with the patented Dynaco 3 speaker stereo arrangement. Information on the proper connection of speakers to the power amplifiers for this system is available from Dynaco on request.

Should you desire to use headphones with your music system, they must be connected to the output of the power amplifier in accordance with the headphone manufacturer's recommendations. It is not possible to connect headphones directly to the PAS preamplifier.

When installing the preamplifier in a cabinet, ventilation is not critical unless continuous duty operation is anticipated, for the preamp produces very little heat. When it is panel mounted, a supporting shelf flush with the bottom of a $1\frac{3}{16}$ " x $3\frac{13}{16}$ " cutout is suggested, and the rubber feet are not used. A PBK bracket kit is available from Dynaco for \$2 which takes the place of the shelf, and accommodates panel thicknesses up to 1". No CODs please.

ADDITIONAL STEREOPHONIC CONTROL FUNCTIONS

Those who are experimentally inclined may occasionally want two stereo functions which are not usually required on a preamplifier because of standardization in all program material. These special functions are phase reversal and channel reversal. Both can be added easily with small double-pole-double-throw switches in the speaker connections to the power amplifier.

A third, or center channel, output can also be added at the output of the power amplifier. A request to Dynaco for either of these data sheets will provide detailed information.

SPECIAL INSTRUCTIONS FOR OPTIONAL 120-240 VOLT POWER TRANSFORMERS

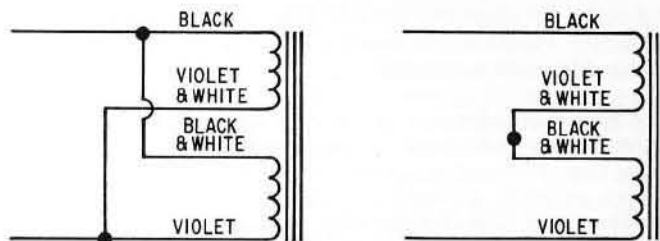

Dynakit preamplifiers supplied with power transformer PA-522 can be wired for use with either 120 or 240 volt, 50 or 60 cycle AC power sources, as follows:

For 120 volt operation

- 1 () Twist together the black and black-white leads, and connect both to lug A of outlet #4 (S).
- 2 () Twist together the violet and violet-white leads, and connect both to lug B of outlet #4 (S).

For 240 volt operation

- 1 () Connect the black lead to lug A of outlet #4 (S).
- 2 () Connect the violet lead to lug B of outlet #4 (S).
- 3 () Twist together above the chassis the violet-white and the black-white leads, and solder them together. Insulate this connection with electrical insulating tape.

ENJOYING STEREOPHONIC SOUND

Stereophonic sound offers an important enhancement of enjoyment of your high fidelity system. The proper setup and use of your stereophonic system will bring considerable satisfaction. However, stereophony introduces problems in high fidelity reproduction which can diminish your enjoyment of your hi fi system unless these problems are understood and corrected. These few notes on the subject should assist materially in the installation and use of a stereophonic system which adds to your listening pleasure.

The pieces of equipment to be used should be as similar as possible in each channel. This is particularly true for the loudspeaker to be used. Different types and brands of speakers have very great differences in frequency response and other important characteristics. If, for example, one speaker has a peak in response at a certain frequency where the other does not, the stereophonic balance will be changed at that frequency. The need for frequent rebalancing is due to this type of dissimilarity.

There has been a relatively high proportion of dissatisfaction with stereo which has arisen because of the attempt to attach an inferior second channel to complete a system. If this channel differs from the first channel it frequently destroys any potential benefits of stereophonic sound.

IN CASE OF TROUBLE

The proper reproduction of monophonic discs through the stereo system requires the cancellation of identical signals (of opposite phase) so that there is no unwanted vertical signal component in the output. This requires either the paralleling of the two sides of the cartridge or the paralleling of the outputs of identical preamps. If the preamps are slightly different, the vertical components cannot be eliminated properly. In the Dynakit preamplifier, the critical components which determine the response characteristics of the preamplifier playback characteristics have a tolerance of only 1% so that this problem cannot cause difficulty. Paralleling is done by using the "A + B" position of the Stereo-Mono Switch.

Channel phasing is a problem of stereo which is readily solved, once understood. If, on a single sound, one speaker cone moves inward while the other moves out, the system is not properly phased, and the sound area between the speakers will lack homogeneity. All tapes and all discs are now reproduced so that their phasing is consistent. Therefore, once phasing of the playback equipment is set it can be maintained for all tape and disc sources without further change.

To check for proper phasing, play a monophonic recording so that one signal comes through both channels. Then move back and forth between the speakers. If phasing is correct, there will be a smooth transition of sound between the speakers. If it is not correct, there will be an intermediate area where the sound will shift from one to the other. If phasing is not correct, it can be rectified by interchanging the two leads between one of the amplifier channels and its associated speaker. There should be no need to change phasing once the system is set up properly.

If there is a drop in volume using a *monophonic* tape or record when switching from "Stereo" to "A+B", this indicates probable incorrect phasing of the cartridge or tape head connections. An interchange of ground and "hot" leads to one of the cartridge channels, or of the two leads to one channel of the tape head will remedy this type of incorrect phasing.

Hum is another problem which the stereo cartridge can introduce. In some cases the use of a common ground lead on the two inputs will introduce hum. Most stereo pickup manufacturers provide separate ground connections for each channel by using four cartridge terminals. The cable shields of the two channels should be kept separated. When a three terminal cartridge arrangement is used, it is useful to intertwine the two shielded cables.

Positioning of the loudspeakers will affect the quality of your stereophonic reproduction. Generally, moderate distances of six to ten feet along the same wall provide the best effect. If greater spacing is required, there may be a "hole-in-the-middle" effect. If this happens, the "blending" of the two channels with the Stereo-Mono switch can improve the naturalness of the sound. However, if extreme distance is required between loudspeakers, a third channel may be useful (requiring a center loudspeaker). Information on adding this is available from Dynaco on request.

The most basic consideration of the installation and use of a stereophonic music system is that stereo alone does not create realism and high quality sound. Two low grade stereo channels will not give the quality of one high grade monophonic channel. There is no substitute for high quality components, carefully installed.

Although your Dynakit has been made as trouble free as possible there is always the possibility that a mistake in assembly or a defective part will prevent it from functioning properly. If any difficulties are encountered, the following routine should be followed.

Check the wiring carefully, making sure that all solder connections are firm, that adjacent parts are not touching, and that no pieces of solder or wire clippings have gone across adjacent points to cause shorts. Make sure the TAPE-INPUT switch is on INPUT.

Are the tube heaters lighted? These do not light brightly but should be visible under dim light. If tubes are not lighted, this indicates a possible open connection through the heater circuit or in one of the tubes. The pilot light is on the same circuit as the tube heaters so that if it lights, it indicates that up to that point the heater circuit is satisfactory. However, if the pilot light glows, and none of the four 12AX7 tubes light, there is probably a defect in the DC heater supply which consists of the selenium rectifier and the two large 2,000 mfd tubular capacitors.

If the tubes light on one printed circuit board and not on the other, there are two possible causes: one, that the connections to the board on one side are not made properly; two, that there is a defective tube on one of the boards. If one tube on the board has an open heater the other will not light because the two are wired in series. A simple test for this is to transfer the two tubes from the other printed circuit board to see if they light in the same sockets. If they do, then the fault was in one of the original tubes.

If there is no signal at all, it is frequently possible to find the trouble through isolation of the specific section of the preamplifier which is at fault. Since there are two independent circuits, each of which is divided into two halves, there are four possible points to which trouble can be isolated. A simple procedure can be established.

If no signal comes through any input, either radio or phono, on either channel, the fault is probably in the power supply. This comprises the 12X4 tube, the quad filter capacitor, and the DC supply for the heaters. Failure in any one of these points will prevent any signal since this power supply is common to all parts of the circuit.

If sound is obtained on one channel only, then trouble shooting can be simplified by comparing the two channels—by interchanging tubes between the two channels to test the tubes, and by comparing wiring between input and output sockets and the selector switch to see what differences exist. The switch and the sockets are symmetrical with respect to the two channels.

Once the trouble is isolated to one channel, it is possible to localize it to either the PC-6 circuit (the amplifier-equalizer section) or to the PC-5 circuit (the tone control section). If a radio will produce a signal but the phonograph will not, for example, the fault is in PC-6, the amplifier-equalizer section. However, if the defect is in the tone control section, the signals will be available at the tape output of the channel involved, but not at the audio output. A simple test is to take one of the output connecting cables from the tape output of the inoperative channel to the phono input of the operating channel. Set the stereo-mono selector on stereo, and play a record (selector switch on "phono") with the input connected only to the inoperative channel. If a signal comes through when this is done—even if the signal is highly distorted due to overloading by misusing the circuit—this indicates that the first part of the inoperative channel is working and the difficulty lies solely in the tone control section, which contains the PC-5 printed circuit board and related components.

SERVICE AND LIMITED WARRANTY

Some hum and hiss will always exist at high volume settings—depending on speaker efficiency—but of course this would be masked by the loud sound. However, it should be negligible at normal listening levels. Hiss will always be apparent at high volume control settings. With the volume control high, and no input connected, hiss should be louder than hum on the phono, tape head and special inputs.

If noise is heard in the preamplifier, all inputs should be disconnected. If the noise disappears, then trouble shooting should be confined to the accessory equipment. Likewise, if the noise is removed when disconnecting the preamplifier from the amplifier, then obviously it is in the preamplifier. On the other hand, if the same noise exists after disconnecting the preamplifier from the power amplifier, then the problem is in the power amplifier.

If the noise drops when the volume control is turned down, then it is in the PC-6 section of the circuit or the selector switch wiring. If the noise is constant at any setting of the volume control, it is in the PC-5 section which follows the volume control.

Hum which is definitely in the preamplifier is usually caused by poor lead orientation or bad solder connections (particularly ground points). Check solder connections by re-heating them, especially at eyelets #4 and #11 on PC-6, eyelets #1 and #8 on PC-5, and the mounting lugs on the quad capacitor used for grounding purposes. Be sure that the wires going to eyelets #4, #11 and #16 on PC-6 are positioned as shown in the underside photograph. Also position the various twisted leads exactly as shown in this photo. Keep AC leads close to the back panel as shown.

Hiss is invariably caused by a tube or noisy resistor. First interchange the tubes on a given circuit board to see if the hiss now reverses channels. It is unlikely that more than one tube would be noisy.

The resistors which may cause hiss are the 150,000 ohm and 1000 ohm resistors in the plate and cathode of the first stage on the PC-6 board. However, if hiss is apparent with the volume control turned fully off, the trouble will be on the PC-5 board; here the 470,000 ohm and 4700 ohm resistors in the first stage on that board are suspect. Others of the same value should be substituted. Note that the 150,000 ohm and 1000 ohm resistors on PC-6 are a very low noise type and, if substitution of another resistor does not lower the hiss, then the original ones should be reinstalled.

Crackling or intermittent noises are usually caused by poor solder connections. Pay particular attention to the solder connections on the selector switch and to terminals #2, #3, #7, #8 and #9 on PC-6. To check for a bad connection, pull at each lead going to a joint with long-nosed pliers and reheat or resolder the connection as necessary.

Please note that when the cover is not on the preamplifier, the hum level will be many times higher than when the cover is on and properly secured with the sheet metal screws. Therefore, test for hum or noise only with the cover in place.

Another aid to trouble shooting which requires a good grade of voltmeter (preferably a vacuum tube voltmeter or a 20,000 ohms per volt meter) can be the taking of voltage measurements. These should be compared with the enclosed voltage chart. Deviations of greater than 20% from these voltages may be an indication of malfunctioning, although deviations as high as 50% will not cause complete lack of sound.

In the event that trouble shooting will not correct the problem, factory consultation is available without charge, and factory service at moderate charge.

This PAS-3X kit is designed to provide reliable performance for a long time when it has been properly assembled and operated. It is intended for operation with normal 120 volt AC lines. The guarantee is void if the line exceeds 130 volts AC. A regulating device is necessary if such excessive line voltage is likely. When the PA-522 power transformer is installed, the nominal line voltage may alternately be 240 volts.

To provide rapid, reliable service, Dynaco has authorized competent, well-equipped service facilities in the U.S. and Canada, in addition to its service facility at the factory. These stations are authorized to make repairs in or out of warranty under the terms below. A current list of these facilities is available on request. It is the owner's responsibility to take or send the unit freight prepaid to the service station. Shipment should be via United Parcel Service or Bus Package Express if possible. REA Express is an alternative (or CN or CP Express in Canada). DO NOT USE PARCEL POST. IT IS NOT A SAFE METHOD OF SHIPPING ELECTRONIC EQUIPMENT. The service facilities cannot handle Parcel Post claims, so repairs thus incurred will be made at the owner's expense at net prices.

Pack the unit properly in the original carton with all protective inserts, or double-pack it with cushioning between the cartons. Insure it for \$150. Include the following information: 1) Your name and complete shipping address (Post Office box numbers are not adequate); 2) the serial number from the cover of this manual, *together with a copy of your dated bill of sale*; 3) the symptoms, brief but complete. Specify if the problem is intermittent.

All components in this PAS-3X are guaranteed against manufacturing defects for a full year from the date of purchase, except tubes, which carry the standard EIA 90 day warranty. Defective parts will be replaced at no charge if they are returned prepaid to Dynaco. Local service stations are not obligated to supply separate parts. If you suspect a defect in a transformer, cutting the leads too short for re-use may void its warranty.

Warranties apply only to the original purchaser. They do not cover units physically or electrically modified, or abused, or units which are incompletely assembled, or units on which other than rosin core solder has been used. Units assembled with acid core solder or paste flux will be returned unserviced.

Dynaco maintains a Technical Services Department to help you locate the source of, and possibly correct a problem yourself. You may write or telephone. When writing, include the serial number and any tests you have made.

If service is required, ship the PAS-3X to the nearest service facility. In-warranty parts will be replaced at no charge, although a nominal service fee will be charged for the labor to diagnose, correct and test the unit to ensure that it meets factory specifications. Shipping charges to and from the service facility are the owner's responsibility. Units will normally be returned on a COD basis via UPS. A 90 day warranty is provided on the service work performed.

After the warranty period Dynaco establishes maximum labor fees which may be charged without prior approval of the owner. Dynaco cannot assume responsibility for service at other than its authorized service facilities.

Dynaco reserves the right to limit the service facility or the fees to two years from the date of purchase. Dynaco assumes no liability or responsibility for damages or injuries sustained in the assembly or operation of this equipment.

PARTS LIST

(Parts of similar type which do not change performance
may sometimes be included as a matter of expediency).

	PART #		PART #
1 PC-5—Tone Control Printed Circuit Assembly	552005	CAPACITORS	
1 PC-6—Amplifier Equalizer Printed Circuit Assembly	552006	1 Quadruple section electrolytic filter can	297806
4 12AX7/ECC-83 Tubes	517003	2 2000 mfd tubular	218208
1 12X4 Tube	514002	2 1.0 mfd tubular	283105
		2 .002 mfd tubular	275202
		2 .02 mfd tubular	245203
		2 .1 mfd tubular	275104
		2 750 pf (precision)	275751
		1 .02 mfd Disc	227203
RESISTORS			
2 10,000 ohm (brown-black-orange)	111103	1 Bracket	717005
2 510,000 ohm (green-brown-yellow)	113514	1 Selenium Rectifier	544235
2 4,700 ohm (yellow-violet-red)	113472	1 Lug Terminal	371001
3 47,000 ohm (yellow-violet-orange)	112473	1 7 Pin Socket	399007
1 33,000 ohm (orange-orange-orange)	112333	2 5 socket strip	355005
1 68,000 ohm (blue-gray-orange)	112683	2 4 socket strip	355004
2 3.3 meg ohm (orange-orange-green)	111335	4 AC Outlets	351001
2 27,000 ohm (red-violet-orange)	112273	6 Knobs — small	764185
2 10 ohm (brown-black-black)	111100	2 Knobs — large	764186
HARDWARE			
43 #4-40 x 1/4" Screw	611245	3 Slide switch DPDT (six lugs)	332201
35 #4-40 Hex Nut	614245	1 Slide switch SPST (two lugs)	331101
35 #4 Lockwasher	617205	1 #53 Lamp	526053
2 #8-32 x 3/8" Screw	611465	1 Lamp bracket	386001
4 #8-32 Hex Nut	614465	2 400K Treble Control*	147404
4 #8 Lockwasher	617405	2 750K Bass Control*	147754
12 #6 Sheet Metal Screws	612339	1 750K Balance Control (dual)	167754
1 #8 x 2 1/4" Screw	611405	1 250K Volume Control (dual)	177254
4 Rubber Feet	859001	1 Piece Sleeving	
1 Grommet	895003	3 pieces Hook-up Wire (red-black-green)	
1 Pilot Light Jewel	834004	1 Blend Switch (Stereo-Mono selector)	331001
1 Spring Clip for pilot light jewel	712001	1 Selector Switch (three deck)	333120
1 Ground Lug	639308	1 Transformer PA-211 (464007) or PA-522(120/240V)	464022
8 3/8" Lockwasher	617065	1 Line Cord	322092
16 3/8" Hex Nuts	614065	2 Shielded Cables	321072
4 6-32 x 3/16" Screws	611355	1 Front Plate	769007
4 6-32 Nuts	614355	1 Chassis — 5 pieces (including cover)	711020
		1 Set Instructions & Warranty card	
		1 Back Panel Label	926001

*special controls—patent

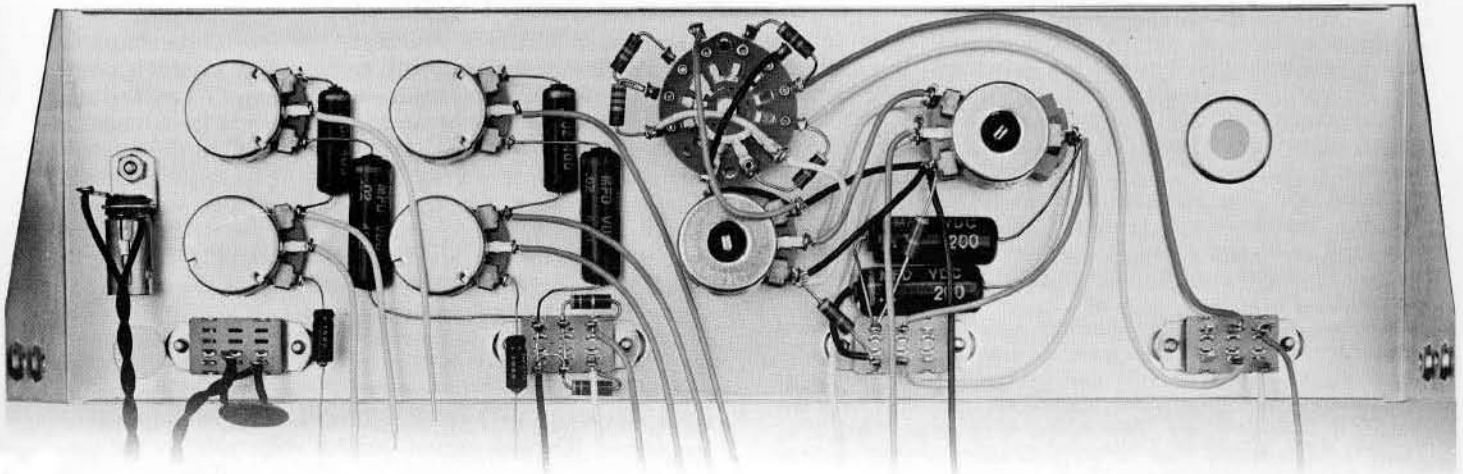

Bob01605@aol.com

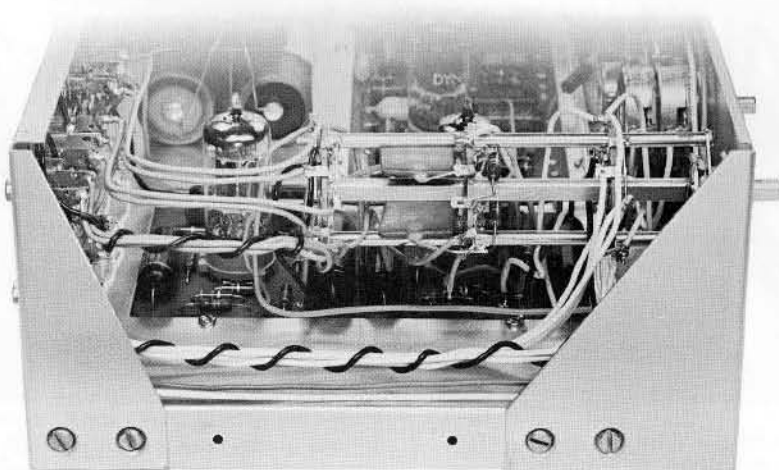
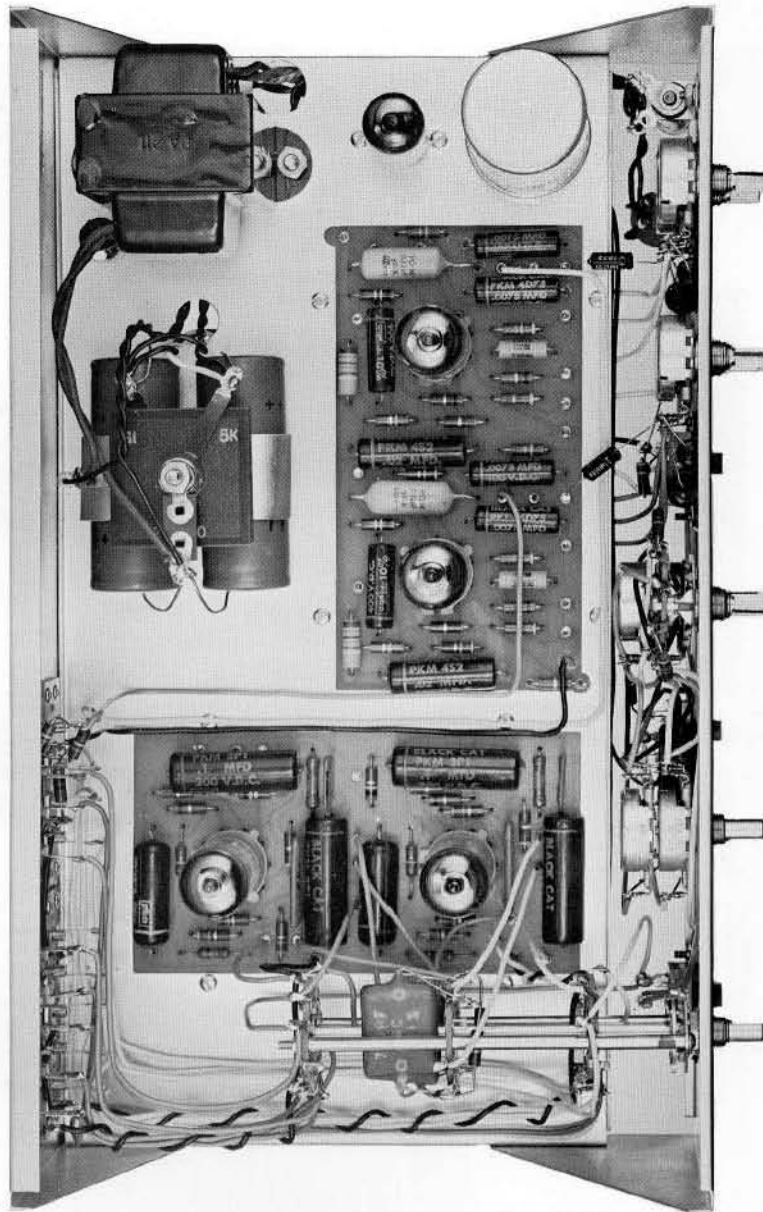

Bob01605@aol.com