

SERVICE MANUAL

C-2a PRE-AMPLIFIER

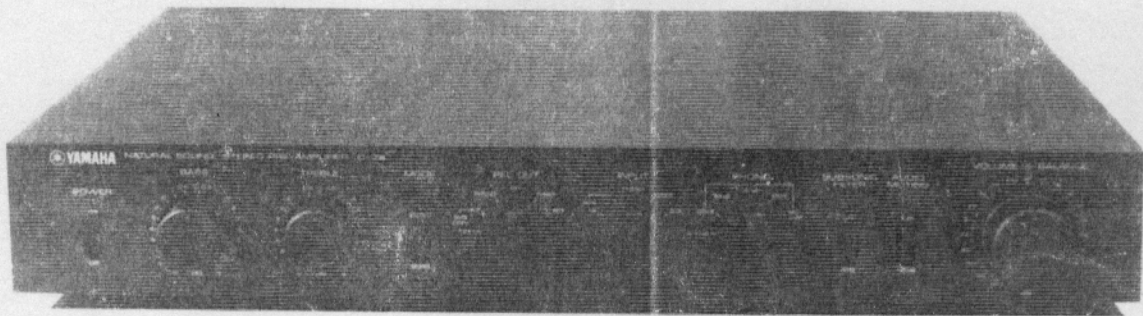

004375

SINCE 1887



YAMAHA

NIPPON GAKKI CO., LTD. HAMAMATSU, JAPAN

NOV. '78 2.2K T.T



Printed in Japan

CONTENTS

PANEL OPERATION	2
PACKAGE INSTRUCTION	4
COMPONENTS LOCATION	5
PARTIAL DISASSEMBLY	6
BLOCK DIAGRAM/LEVEL DIAGRAM	7
SPECIFICATIONS	8
ADJUSTMENT	9
ADJUSTING POINTS	10
CIRCUIT BOARDS	11
SCHEMATIC DIAGRAM	12

PANEL OPERATION

FRONT PANEL

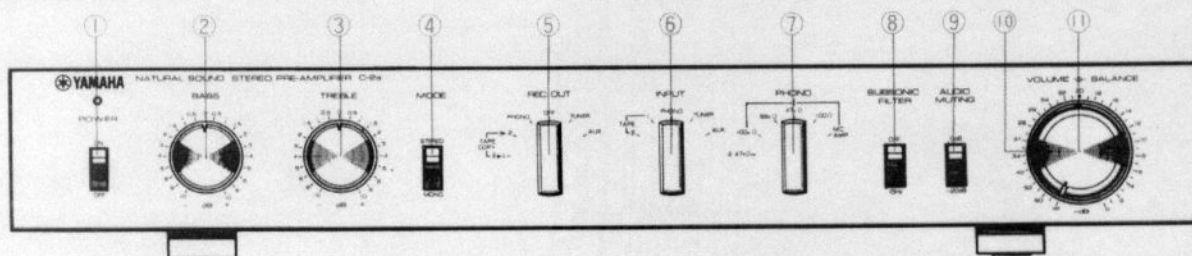

- | | |
|---------------------------|--------------------------|
| ① POWER Switch | ⑦ PHONO Selector Switch |
| ② TONE CONTROL (BASS) | ⑧ SUBSONIC FILTER Switch |
| ③ TONE CONTROL (TREBLE) | ⑨ AUDIO MUTING Switch |
| ④ MODE Switch | ⑩ BALANCE Control |
| ⑤ REC OUT Selector Switch | ⑪ VOLUME Control |
| ⑥ INPUT Selector Switch | |

REAR PANEL

U.S. and CANADIAN Models

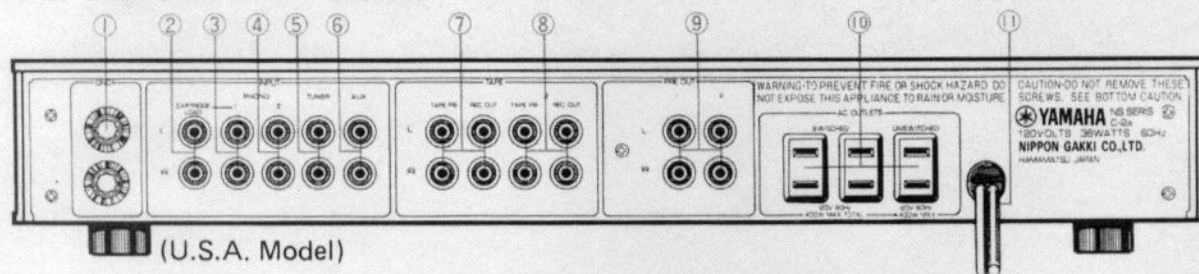

- | | |
|--------------------------------|-----------------------|
| ① Ground Terminals | ⑦ TAPE 1 PB/REC Jacks |
| ② PHONO-1 CARTRIDGE LOAD Jacks | ⑧ TAPE 2 PB/REC Jacks |
| ③ PHONO-1 Input Jacks | ⑨ PRE OUT 1,2 Jacks |
| ④ PHONO-2 Input Jacks | ⑩ AC OUTLETS |
| ⑤ TUNER Input Jacks | ⑪ AC Power Cord |
| ⑥ AUX Input Jacks | |

NORTH EUROPEAN, BRITISH and AUSTRALIAN Models

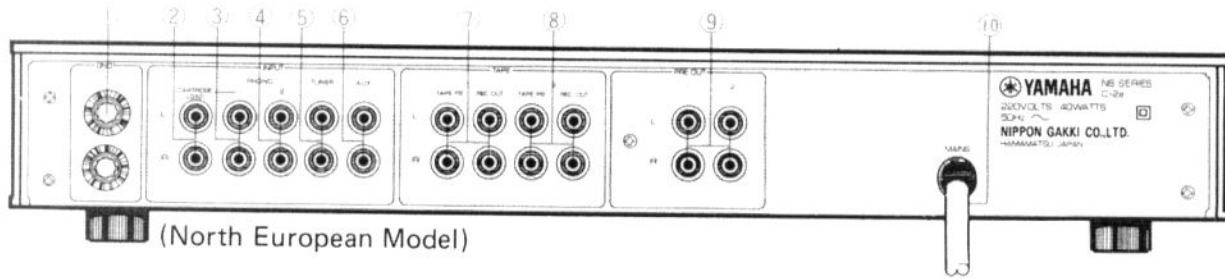

- ① Ground Terminals
- ② PHONO-1 CARTRIDGE LOAD Jacks
- ③ PHONO-1 Input Jacks
- ④ PHONO-2 Input Jacks
- ⑤ TUNER Input Jacks
- ⑥ AUX Input Jacks
- ⑦ TAPE 1 PB/REC Jacks
- ⑧ TAPE 2 PB/REC Jacks
- ⑨ PRE OUT 1,2 Jacks
- ⑩ AC Power Cord

GENERAL and EUROPEAN Models

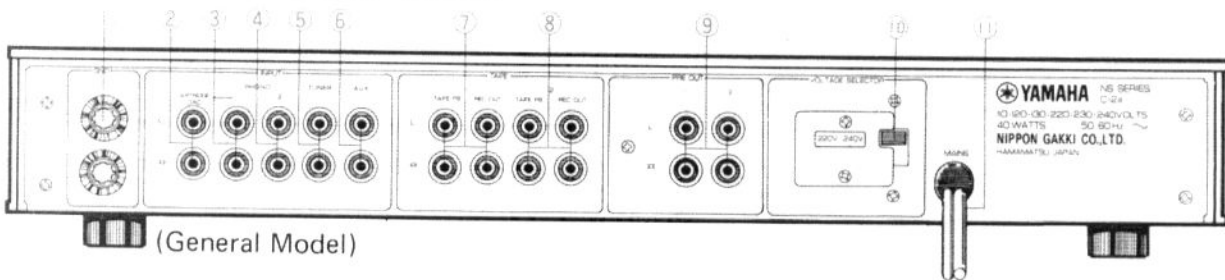

- ① Ground Terminals
- ② PHONO-1 CARTRIDGE LOAD Jacks
- ③ PHONO-1 Input Jacks
- ④ PHONO-2 Input Jacks
- ⑤ TUNER Input Jacks
- ⑥ AUX Input Jacks
- ⑦ TAPE 1 PB/REC Jacks
- ⑧ TAPE 2 PB/REC Jacks
- ⑨ PRE OUT 1,2 Jacks
- ⑩ VOLTAGE SELECTOR
- ⑪ AC Power Cord

PACKAGE INSTRUCTION

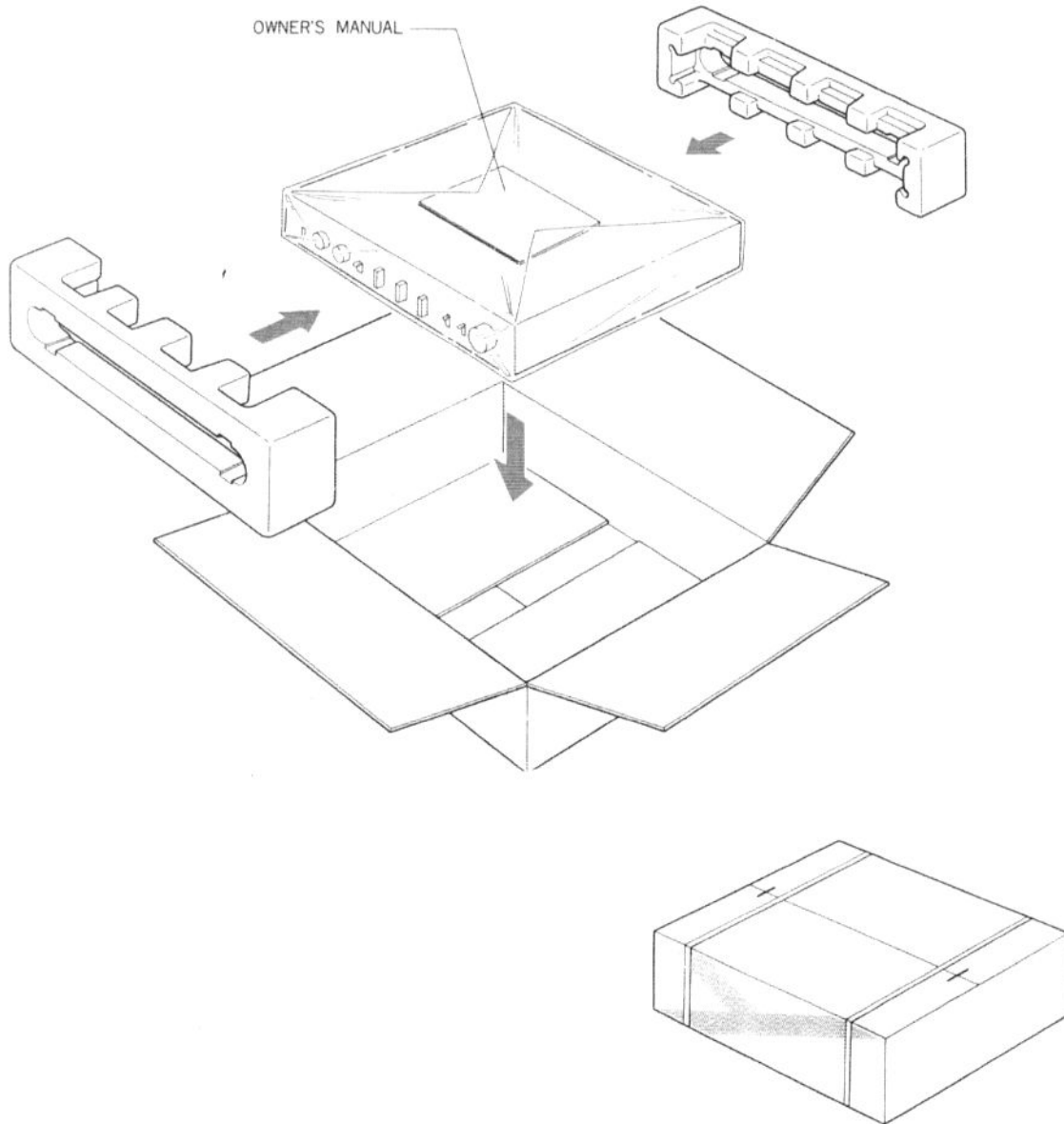

COMPONENTS LOCATION

TOP VIEW

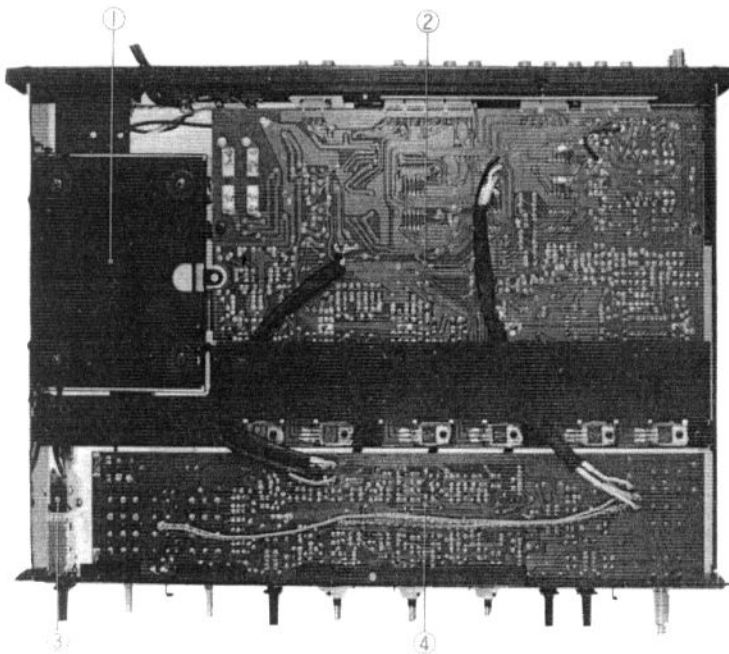

- ① Power Transformer
- ② EQ C. Board
(Canadian : NA07186)
(N.European, British and European : NA07187)
(General and Australian : NA07188)
(U.S.A. : NA07237)
- ③ Power Switch
- ④ Tone Control C. Board
(NA07236)

BOTTOM VIEW

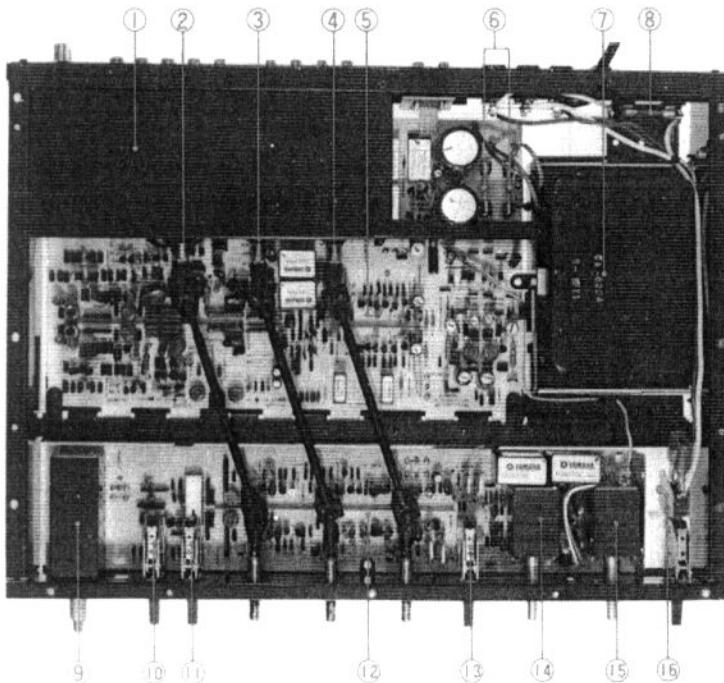

- ① MC Shield
- ② Phono Selector Switch
- ③ Input Selector Switch
- ④ Rec out Selector Switch
- ⑤ EQ C. Board
(Canadian : NA07186)
(N.European, British and European : NA07187)
(General and Australian : NA07188)
(U.S.A. : NA07237)
- ⑥ Fuse (F201, F202)
- ⑦ Power Transformer
- ⑧ Fuse
- ⑨ Volume/Balance VR
- ⑩ Audio Muting Switch
- ⑪ Subsonic Filter Switch
- ⑫ Tone Control C. Board
(NA07236)
- ⑬ Mode Switch
- ⑭ Treble VR
- ⑮ Bass
- ⑯ Power Switch

PARTIAL DISASSEMBLY

1. Removing the Bottom Cover

Remove screws ① through ⑦ in photo 1.

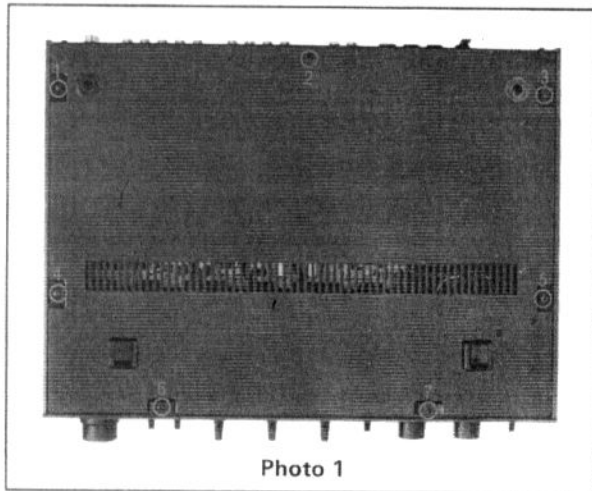

2. Removing the Case

- (1) Remove knobs BASS , TREBLE , REC OUT, INPUT , PHONO , VOLUME , BALANCE by loosening the set screws with a 1.5φ hexagonal wrench.
- (2) Remove screws ① ~ ⑪ in photo 2.
- (3) Pull out LED (Power supply indicator lamp) connector #2 in photo 3.
- (4) Pull chassis out gently from the case and front panel which are constructed as a unit.

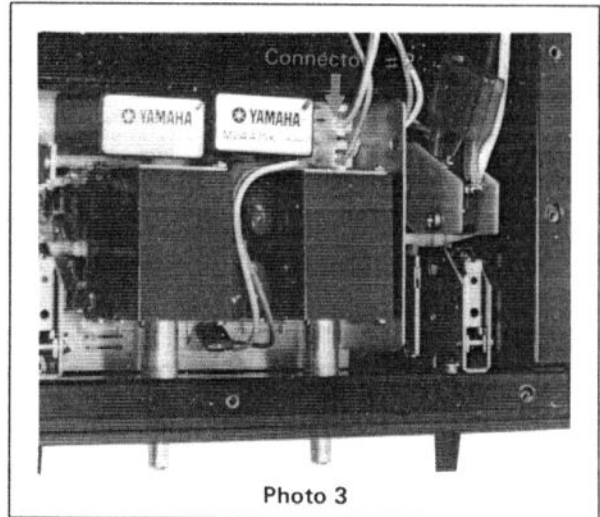
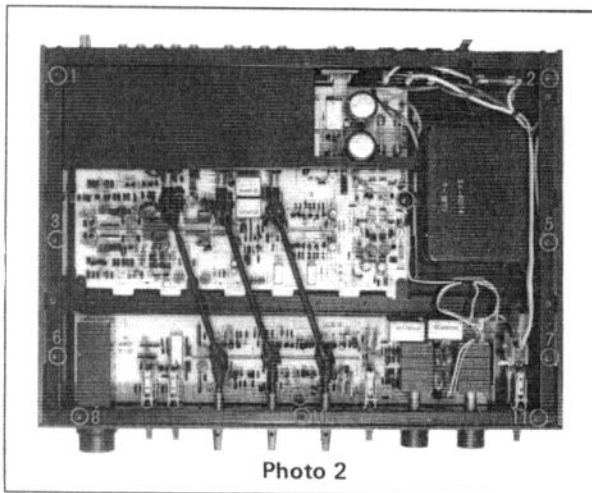

3. Removing MC shield

- (1) Remove screws ① and ②
- (2) Lift the side frame of the MC shield and push to the left.
The hook is detached and MC shield is removal.

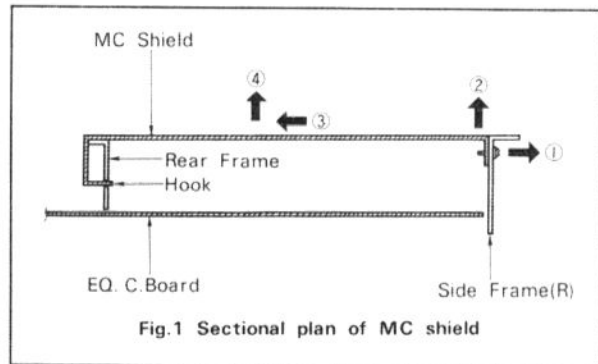
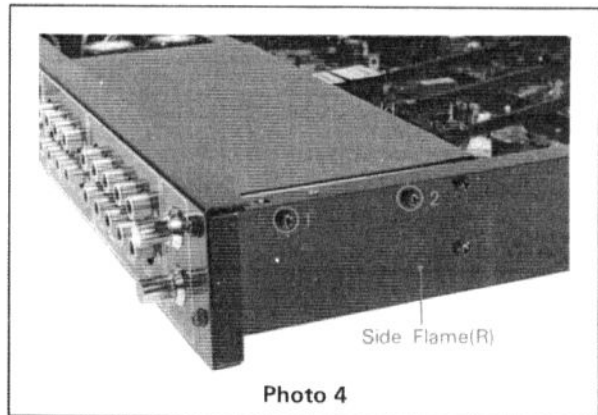

BLOCK DIAGRAM/LEVEL DIAGRAM

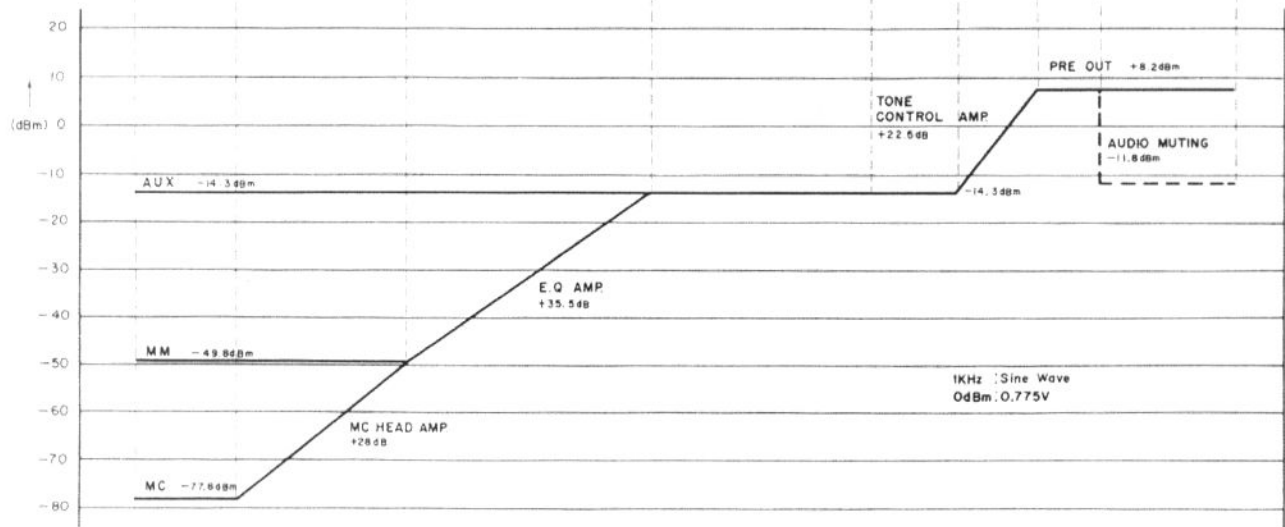
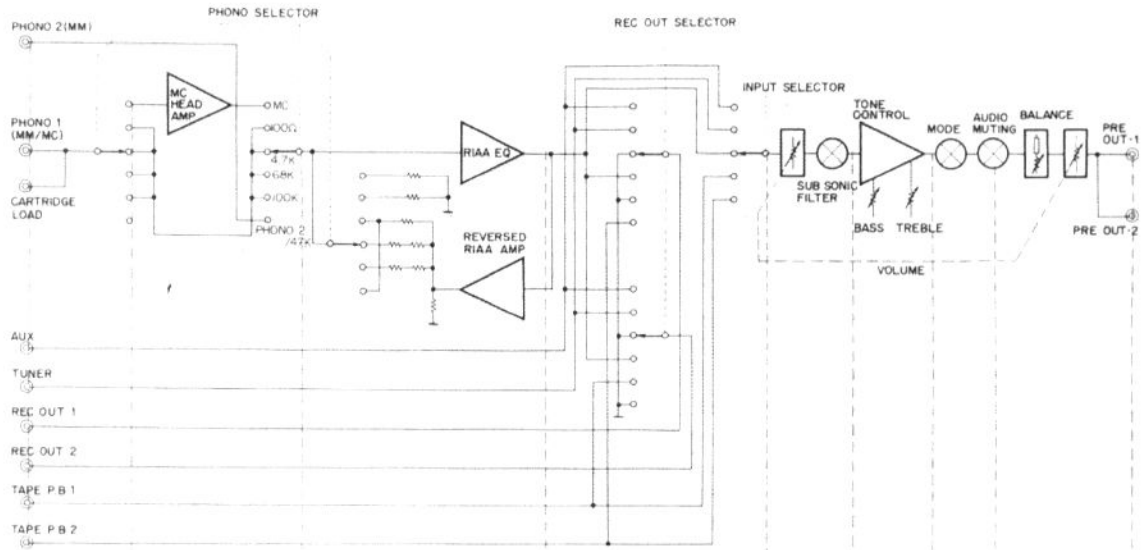

SPECIFICATIONS

Input Sensitivity/Impedance (at 1kHz)

PHONO-1 (MM)	2.5mV/100 Ω , 47k Ω , 68k Ω , 100k Ω
PHONO-1 (MC)	100 μ V/50 Ω
PHONO-2	2.5mV/47k Ω
AUX, TUNER, TAPE-1, 2	150mV/47k Ω

Maximum Input Level

PHONO-1, 2 (MM)	350mV at 1kHz 0.01% T·H·D
PHONO-1 (MC)	10mV at 20kHz 0.03% T·H·D
AUX, TUNER, TAPE-1, 2	1V at 20Hz to 20kHz 0.01% T·H·D

Output Level/Impedance (at 1kHz)

PRE OUT-1, 2	2.0V/250 Ω
REC OUT-1, 2	150mV/100 Ω

Maximum Output Level (20 to 20,000Hz)

PRE OUT-1, 2	15V/0.01% T·H·D
REC OUT-1, 2	18V/0.01% T·H·D

Total Harmonic Distortion Ratio (20 to 20,000Hz)

PHONO-1, 2 (MM) to REC OUT-1, 2	less than 0.003% (10V output)
PHONO-1 (MC) to REC OUT-1, 2	less than 0.01% (1V output)
AUX, TUNER, TAPE-1, 2 to PRE OUT-1, 2	less than 0.003% (10V output)

Total Harmonic Distortion Ratio by HP-1B Audio Analyzer

PHONO 1, 2 (MM) to REC OUT (20 to 20,000Hz)	less than 0.0007% (1.5V output)
AUX, TUNER to PRE OUT (20 to 20,000Hz)	less than 0.0007% (2V output)

RIAA Deviation

PHONO-1, 2	20 to 20,000Hz \pm 0.2dB
PHONO-1 (MC)	20 to 20,000Hz \pm 0.3dB

Frequency Response

AUX, TUNER, TAPE-1, 2	10Hz to 100kHz \pm 0.2dB
-----------------------	----------------------------

Tone Control Characteristics

BASS Turnover Frequency	350Hz
BASS Boost/Cut	\pm 10dB at 20Hz
TREBLE Turnover Frequency	3.5kHz
TREBLE Boost/Cut	\pm 10dB at 50kHz

Subsonic Filter Characteristics

Audio Muting	-20dB
--------------	-------

Signal-to-Noise Ratio (IHF A-Network)

PHONO-1, 2	better than 92dB
PHONO-1 (MC)	better than 78dB
AUX, TUNER, TAPE-1, 2	better than 105dB

Residual Noise

	less than 0.03 μ V (Vol min.)
--	--------------------------------------

Channel Separation

PHONO-1, 2 (MM) to PRE OUT-1, 2	90dB (Vol. max. 1kHz 0 Ω shorted)
PHONO-1 (MC) to PRE OUT-1, 2	60dB (Vol. max. 1kHz 0 Ω shorted)
AUX, TUNER, TAPE-1, 2 to PRE OUT-1, 2	90dB (Vol. max. 1kHz 1k Ω shorted)

Power Supply

U.S.A & Canadian Models	120V AC, 60Hz
European & General Models	110/130V, 220/240V AC, 50/60Hz

North European Model

British & Australian Models	240V AC, 50Hz
-----------------------------	---------------

Power Consumption

AC Outlet	SWITCHED x2
(U.S.A. & Canadian Models)	Total 400W max. UNSWITCHED x1 Total 400W max.

Dimensions (WxHxD)

	435x72x320mm
--	--------------

Weight

	(17"x2-5/6"x12-19/32") 7.9kg (17 lbs 6 oz)
--	--

Specifications subject to change without notice.

ADJUSTMENT

PRIOR TO ADJUSTMENT

- Adjustment is to be carried out only after 3 or 4 minutes have passed following switch-on of power, and when the amplifier's operation stabilizes.
- The volume knob should be set to minimum.

Step	Adjustment Items	Adjustment	Terminals/Test point	Rating or Standard	Instrument
1	Power supply voltage	VR207 (+B) VR208 (-B)	TP9(+) - TP10(-) (+B) TP8(-) - TP10(+) (-B)	+40V \pm 0.2V -40V \pm 0.2V	Digital multi meter
2	Checking muting operations		Check and confirm that relays are ON in 4 through 7 seconds after power ON, and that the collector voltage of TR262 is 36V \pm 3V.		
3	Distortion Adj. of MC amp. section	VR201 (Lch) VR202 (Rch)	InputPHONO 1 OutputREC OUT Oscillator (20kHz) Rg 22 Ω (Refer to Fig.2) Switches INPUTPHONO PHONO .. MC AMP REC OUT PHONO	Adjust so that distortion will be minimum.	Oscillator Distortion meter
4	DC offset of equalizer section	VR203 (Lch) VR204 (Rch)	TP1(+) - TP2(-) (Lch) TP3(+) - TP2(-) (Rch)	0 \pm 200mV	Digital multi meter
5	Idling current of equalizer section	VR205 VR206	TP6(+) - TP7(-) TP4(+) - TP5(-)	23mV \pm 10mV	Digital multi meter
6	DC offset of Tone control section	VR501 (Lch) VR502 (Rch)	TP3(+) - TP2(-) (Lch) TP1(+) - TP2(-) (Rch) Knobs and Switches BALANCE Center VOLUME Max. AUDIO MUTING 0dB SUBSONIC FILTER OFF MODE STEREO TREBLE Center BASS 10dB	0 \pm 25mV	Digital multi meter

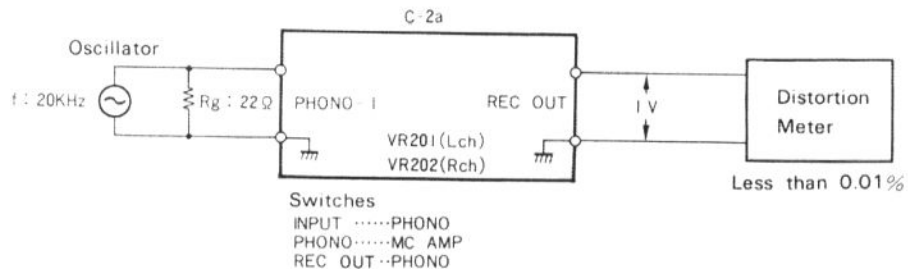
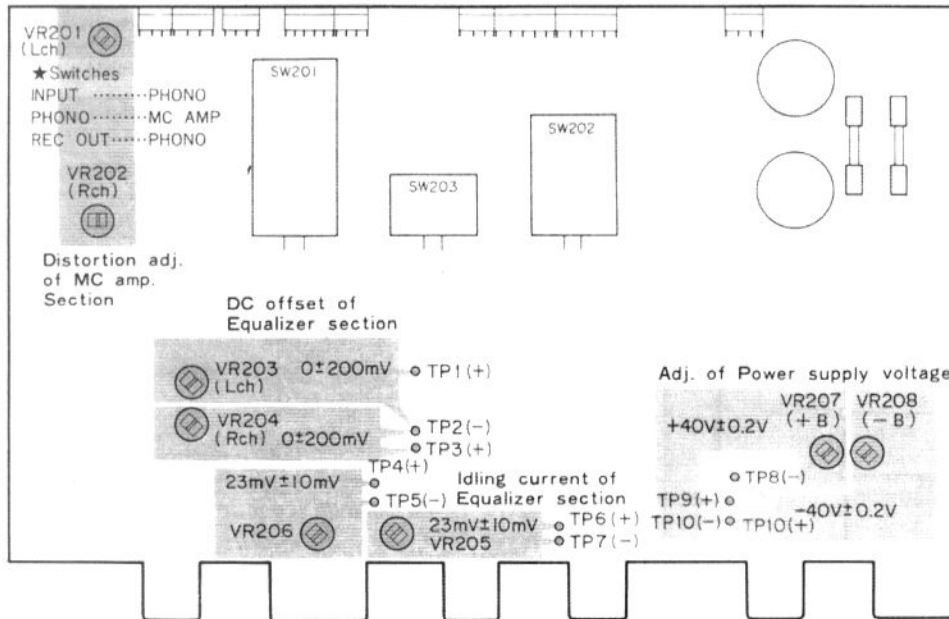

Fig.2 Distortioh adj. of MC amp. section

ADJUSTING POINTS

EQ C. Board



Tone Control C. Board

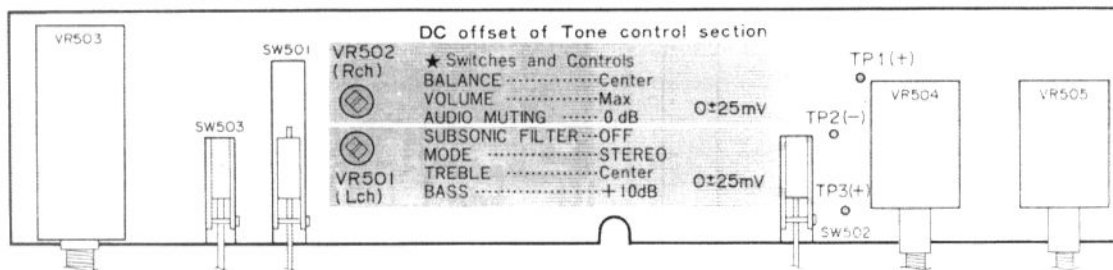

CIRCUIT BOARDS

CARTRIDGE LOAD PHONO 1 2 TUNER AUX TAPE PB 1 REC OUT

PIN JACK C. BOARD

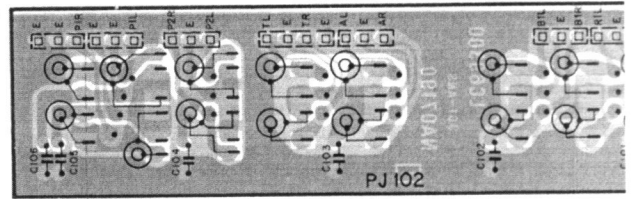

MC HEAD AMP. C. BOARD

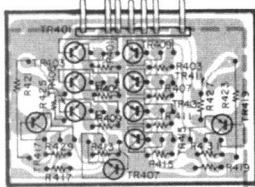

MC Head Amp. Circuit

MC HEAD AMP. C. BOARD

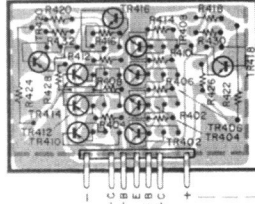

● The circuit board diagram is the diagram as viewed from the parts side.

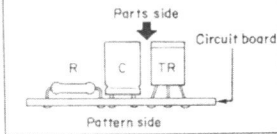

EQ C. BOARD

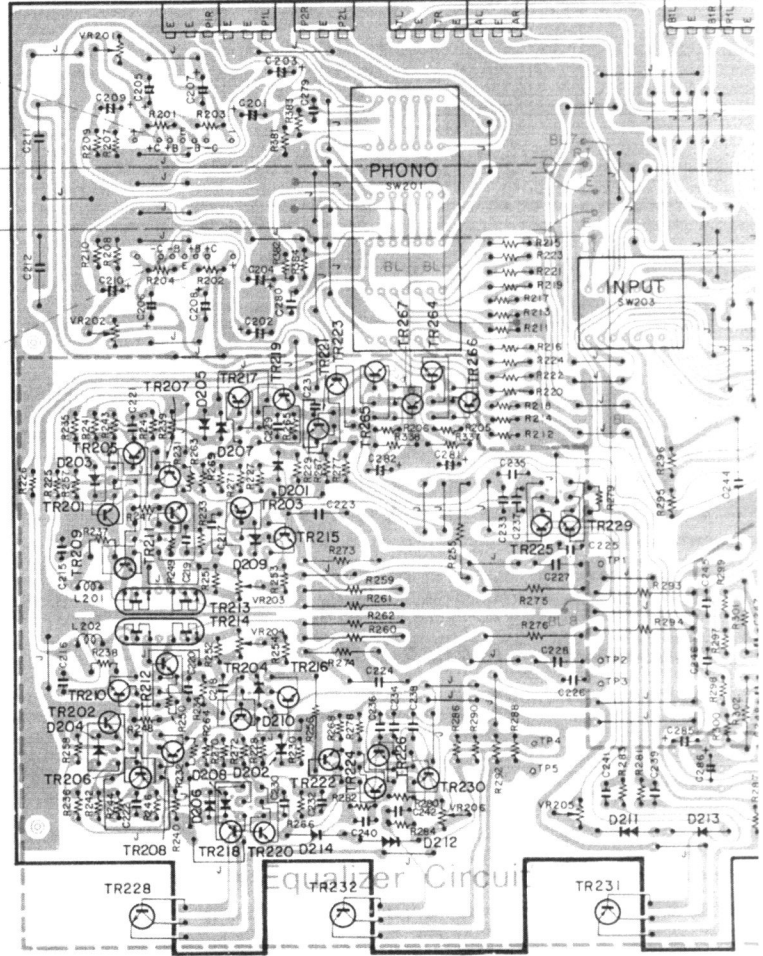

TONE CONTROL C. BOARD

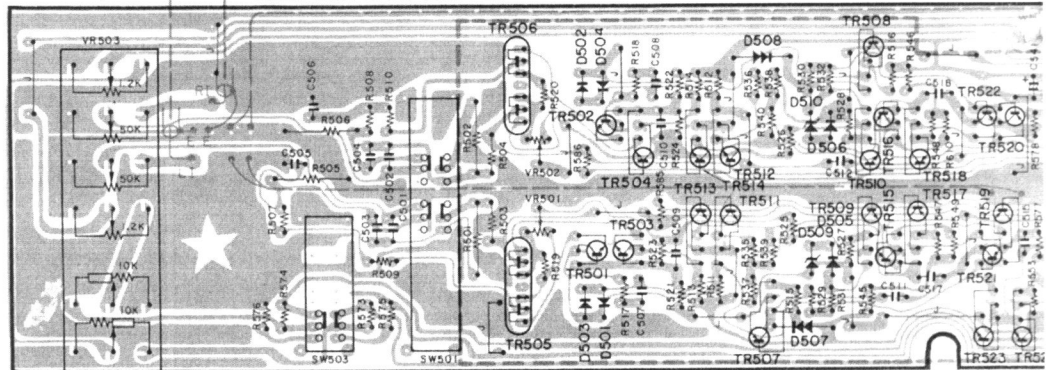

VOLUME BALANCE AUDIO MUTING SUBSONIC FILTER

PB REC OUT TAPE PB REC OUT

1 PRE OUT 2

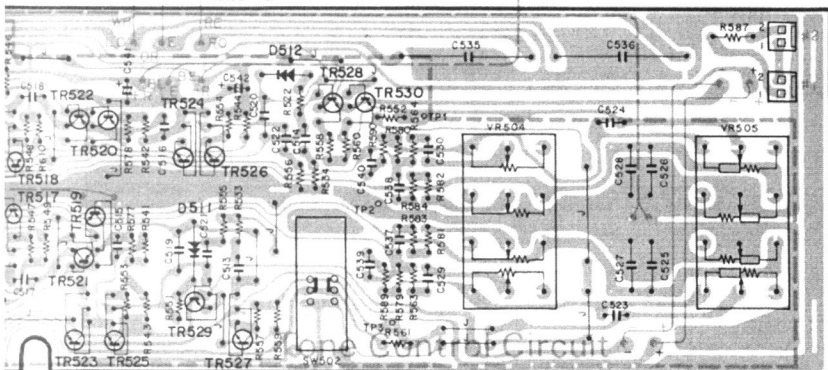
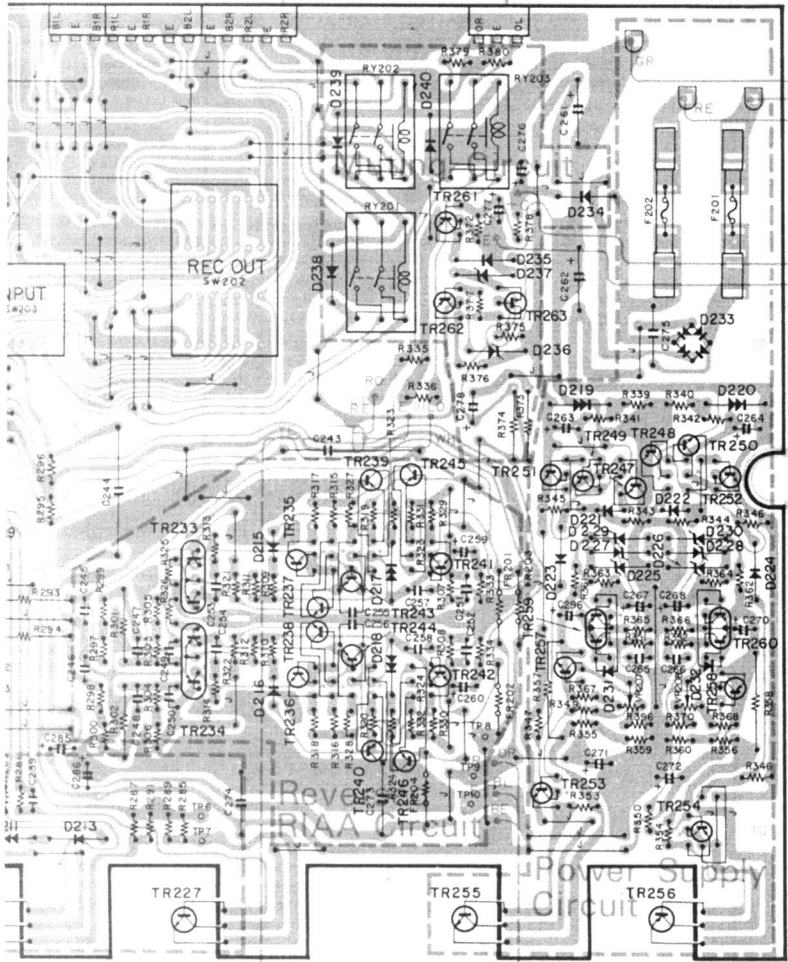
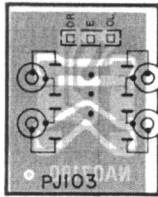
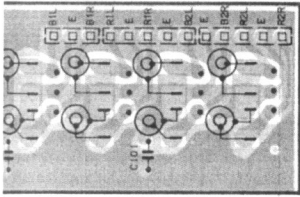

MODE TREBLE BASS

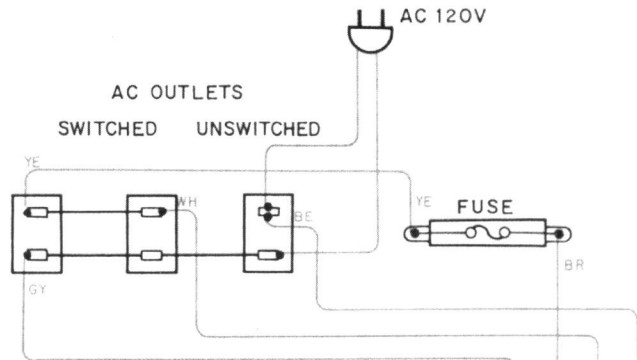

POWER TRANSFORMER

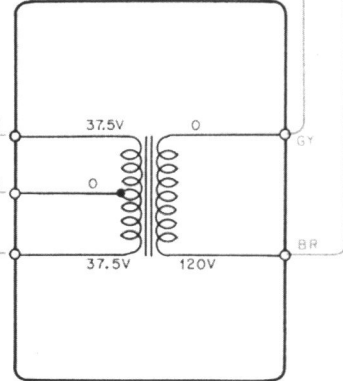

This wiring is shown in accordance with the U.S. and CANADIAN model.

WIRE COLOR ABBREVIATIONS

- BL.....Black
- BR.....Brown
- RE.....Red
- OR.....Orange
- YE.....Yellow
- GR.....Green
- BE.....Blue
- GY.....Gray*
- WH.....White

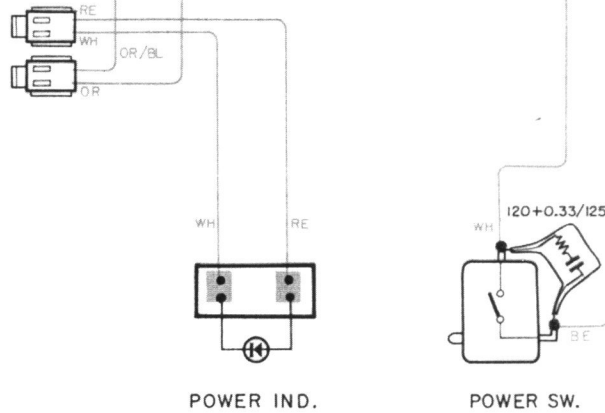

POWER IND.

POWER SW.

9

10

11

TONE CONTROL

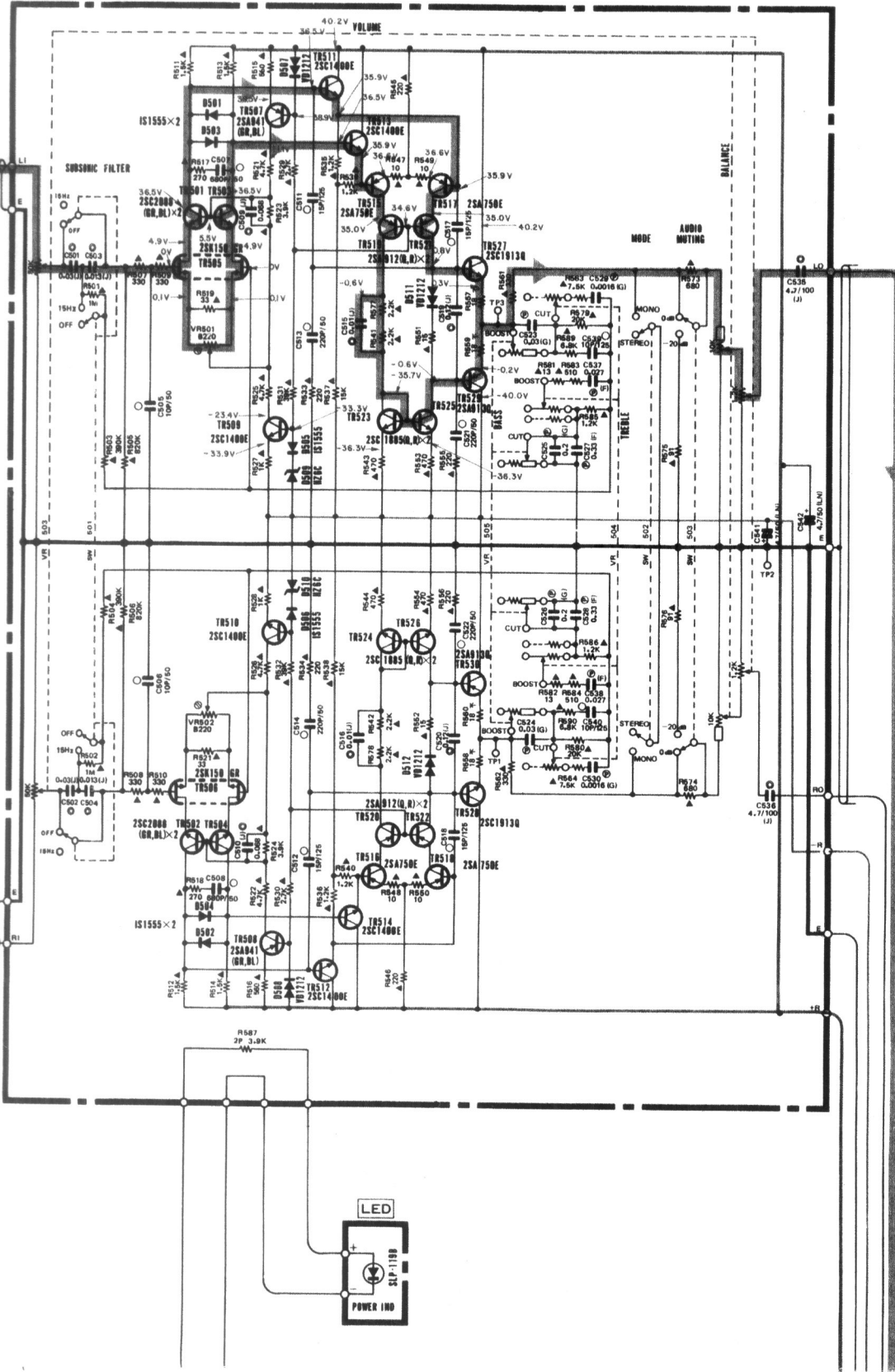

- 

ECB
2SA673
2SC1213
- 

ECB
2SA750
2SA912
2SA941
2SA992
2SB737
2SC1400
2SC1885
2SC2088
2SD786
- 

DGS
2SK68A
- 

ECB
2SA743
2SA914
2SC1212
2SC1953
- 

BCE
2SP56C

Part No.	F201, F202	C261, C262
Destination		
U.S. & Canadian Models	1 JA 250V	680μF/63WV
Other Area Models	T1.0A 250V	1,000μF/80WV

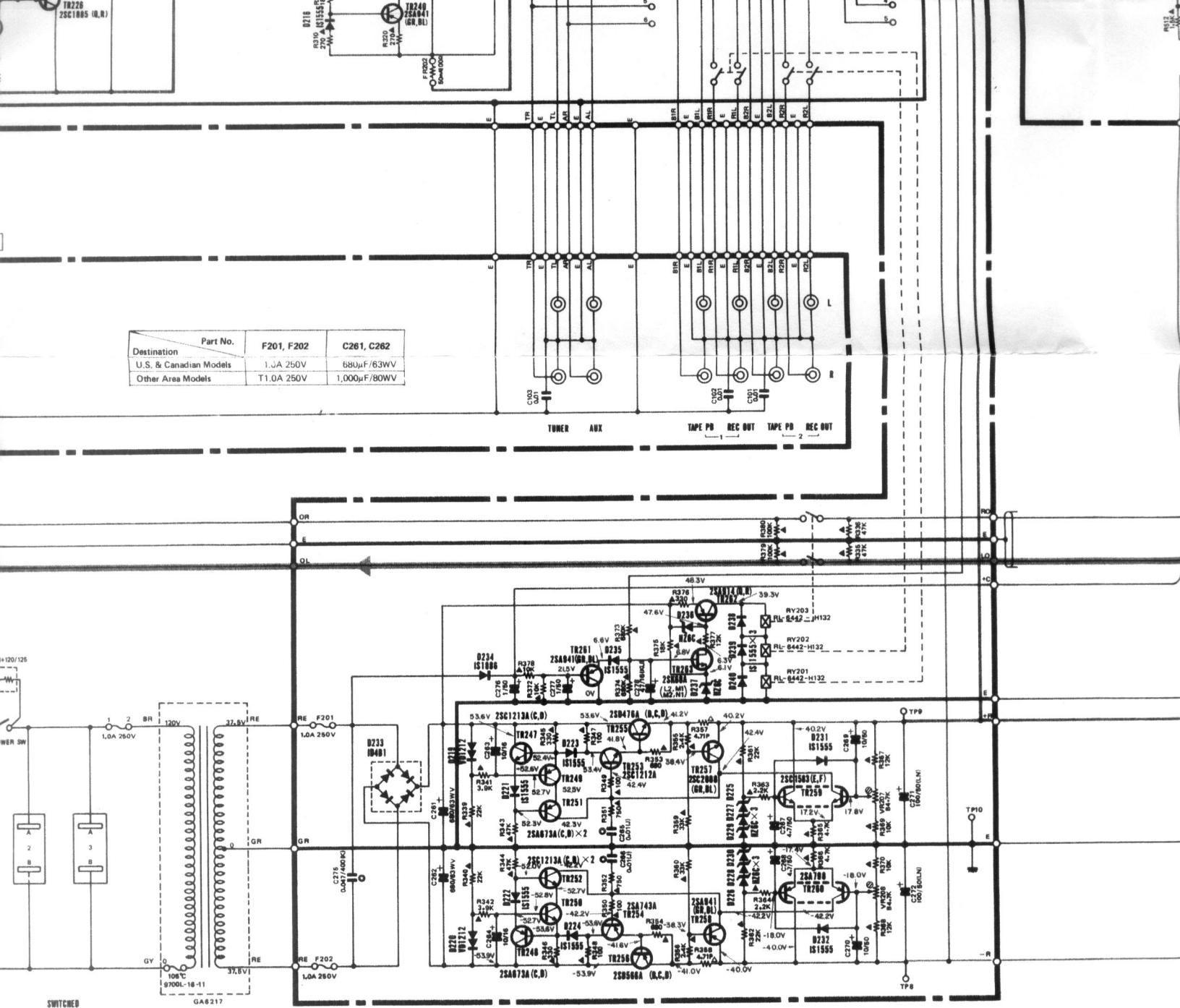

North European Model

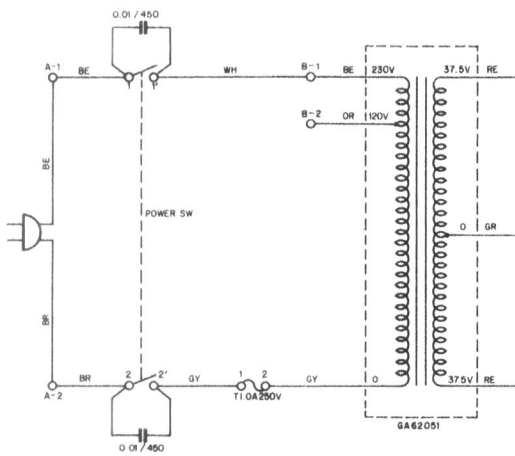

General Model

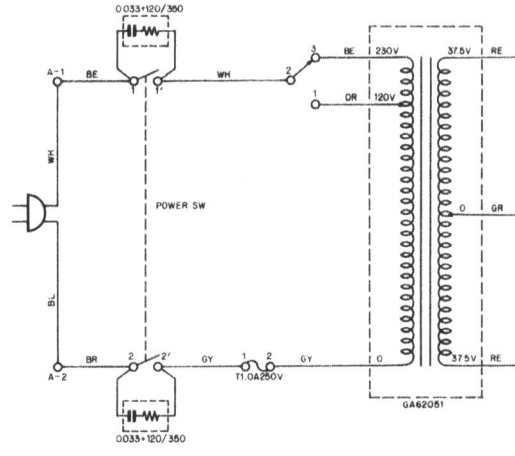

British Model

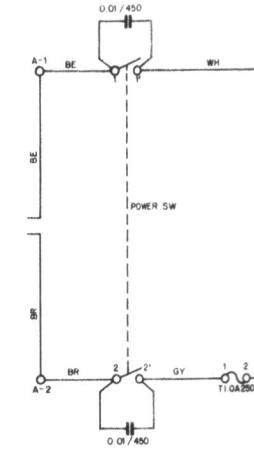

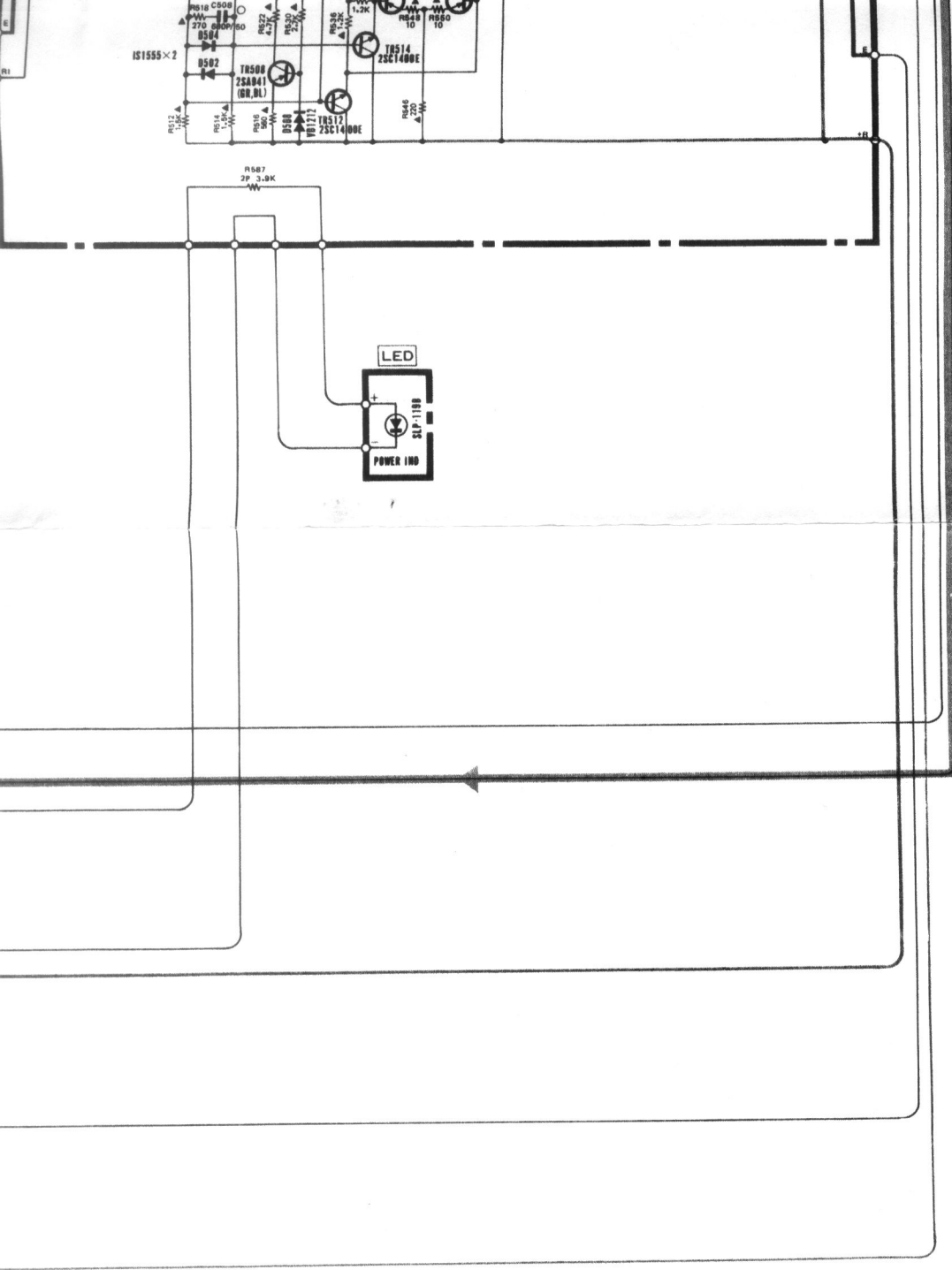

- ECB
2SA750
2SA912
2SA941
2SA992
2SB737
2SC1400
2SC1885
2SC2088
2SD786
- DGS
2SK68A
- ECB
2SA743
2SA914
2SC1212
2SC1953
- BC E
2SB566
2SD476
- ECB
2SA913
2SC1913
- BC E C B
2SA798
2SC1583
- DGS DGS
2SK101
- DGS SDG
2SK150
- A
VDI212
- A
ISI555
ISI886
HZ6C
- ID4BI

British Model

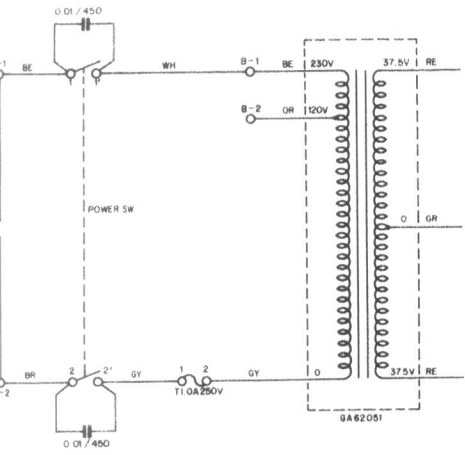

Australian Model

