

POWER AMPLIFIER

CF2000

SERVICE MANUAL



■ CONTENTS

SPECIFICATIONS	3
PANEL LAYOUT	4
CIRCUIT BOARD LAYOUT	5
WIRING.....	6
DIMENSIONS	7
BLOCK DIAGRAM	8
DISASSEMBLY PROCEDURE.....	9
IC BLOCK DIAGRAM	11
CIRCUIT BOARDS	12
INSPECTIONS.....	17
PARTS LIST	
OVERALL CIRCUIT DIAGRAM	

This document is printed on chlorine free (ECF) paper with soy ink.

IMPORTANT NOTICE

This manual has been provided for the use of authorized Yamaha Retailers and their service personnel. It has been assumed that basic service procedures inherent to the industry, and more specifically Yamaha Products, are already known and understood by the users, and have therefore not been restated.

WARNING: Failure to follow appropriate service and safety procedures when servicing this product may result in personal injury, destruction of expensive components and failure of the product to perform as specified. For these reasons, we advise all Yamaha product owners that all service required should be performed by an authorized Yamaha Retailer or the appointed service representative.

IMPORTANT: This presentation or sale of this manual to any individual or firm does not constitute authorization, certification, recognition of any applicable technical capabilities, or establish a principal-agent relationship of any form.

The data provided is believed to be accurate and applicable to the unit(s) indicated on the cover. The research engineering, and service departments of Yamaha are continually striving to improve Yamaha products. Modifications are, therefore, inevitable and changes in specification are subject to change without notice or obligation to retrofit. Should any discrepancy appear to exist, please contact the distributor's Service Division.

WARNING: Static discharges can destroy expensive components. Discharge any static electricity your body may have accumulated by grounding yourself to the ground bus in the unit (heavy gauge black wires connect to this bus).

IMPORTANT: Turn the unit OFF during disassembly and parts replacement. Recheck all work before you apply power to the unit.

WARNING: CHEMICAL CONTENT NOTICE!

The solder used in the production of this product contains LEAD. In addition, other electrical/electronic and/or plastic (where applicable) components may also contain traces of chemicals found by the California Health and Welfare Agency (and possibly other entities) to cause cancer and/or birth defects or other reproductive harm.

DO NOT PLACE SOLDER, ELECTRICAL/ELECTRONIC OR PLASTIC COMPONENTS IN YOUR MOUTH FOR ANY REASON WHAT SO EVER!

Avoid prolonged, unprotected contact between solder and your skin! When soldering, do not inhale solder fumes or expose eyes to solder/flux vapor!

If you come in contact with solder or components located inside the enclosure of this product, wash your hands before handling food.

IMPORTANT NOTICE FOR THE UNITED KINGDOM**Connecting the Plug and Cord**

IMPORTANT. The wires in this main lead are coloured in accordance with the following code:

BLUE: NEUTRAL
BROWN: LIVE

As the colours of the wires in the main lead of this apparatus may not correspond with the coloured markings identifying the terminals in your plug, proceed as follows:

The BLUE wire must be connected to the terminal that is marked with the letter N (or coloured BLACK).

The BROWN wire must be connected to the terminal that is marked with the letter L (or coloured RED).

Be certain that neither core is connected to the earth terminal of the three pin plug.

■ WARNING

Components having special characteristics are marked  and must be replaced with parts having specification equal to those originally installed.

■ SPECIFICATIONS

Power Output Level	1 kHz, THD+N=1 %	8 Ω/STEREO	450 W + 450 W
		4 Ω/STEREO	650 W + 650 W
	1 kHz 20 ms, non-clip	8 Ω/BRIDGE	1300 W
		2 Ω/STEREO	1000 W + 1000 W
		4 Ω/BRIDGE	2000 W
Power Bandwidth	THD+N=0.2 % (half power)		10 Hz—40 kHz
Total Harmonic Distortion (THD+N)	20 Hz—20 kHz (half power)		0.1%
	4–8 Ω/STEREO	8 Ω/BRIDGE	
Intermodulation Distortion	60 Hz:7 kHz, 4:1, half power		0.1%
	4–8 Ω/STEREO	8 Ω/BRIDGE	
Frequency Response	8 Ω, Po=1W		0 dB, +0.5 dB, -1 dB f=20 Hz—50 kHz
Channel separation	Half power, RL=8 Ω LEVEL=max., input 600 Ω shunt		≥70 dB, 1 kHz
Residual Noise	LEVEL=min., 12.7 kHz LPF, IHF-A network		≤ -70 dB
S/N Ratio	12.7 kHz LPF		104 dB
Damping Factor	RL=8 Ω, 1 kHz		≥200
Sensitivity	LEVEL=max., rated power into 8 Ω		+4 dB
Voltage Gain	LEVEL=max.		33.8 dB
Input Impedance			30 kΩ (balanced), 15 kΩ (unbalanced)
Controls	Front panel	POWER switch (push on/push off) LEVEL attenuator (31 position) x2	
	Rear panel	Mode switch (STEREO/BRIDGE/PARALLEL) YAMAHA SPEAKER PROCESSING switch (ON/OFF)	
Connectors	Input	XLR-3-31 type (balanced) L+R 1/4" phone jack (balanced) L+R	
	Output	1/4" phone jack L+R 5-way binding post x1	
Indicators	POWER	x1 (green)	
	PROTECTION	x1 (red)	
	TEMP	x1 (red) heatsink temp ≥85 °C	
	CLIP	x2 (red)	
	SIGNAL	x2 (green) output voltage ≥2 V x2 (yellow) output voltage ≥20 V	
Protection Circuit			POWER switch on/off mute DC detection TEMP (heatsink temp ≥90 °C) PC limiter: RL ≤1 Ω
Fan Circuit			Stop—low speed (50 °C)—variable—high Speed (70 °C)
Limiter Circuit			Comp: THD≥0.5 %
Power requirements			U.S.A. & Canada 120 V AC, 60 Hz Europe 230 V AC, 50 Hz Australia 240 V AC, 50 Hz
Idle Power Consumption			30 W
1/8 Power Consumption (4 Ω)			400 W
Maximum Power Consumption (4 Ω)			2000 W
Dimensions (W x H x D)			480 x 88 x 416 mm (18.9 x 3.46 x 16.4 inches)
Weight			14 kg (30.9 lbs)
AC Power cord length			2.3 m

* 0 dB=0.775 V rms, half power = 1/2 output level.

■ PANEL LAYOUT

● Front Panel

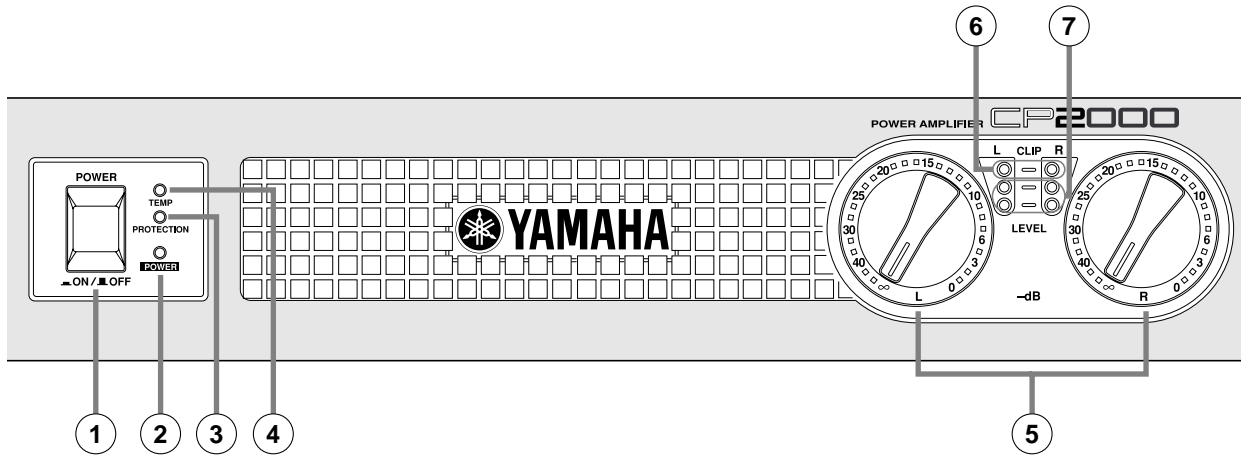

- ① POWER switch
- ② POWER indicator
- ③ PROTECTION indicator
- ④ TEMP indicator

- ⑤ Level controls
- ⑥ CLIP indicators
- ⑦ LEVEL indicators

● Rear Panel

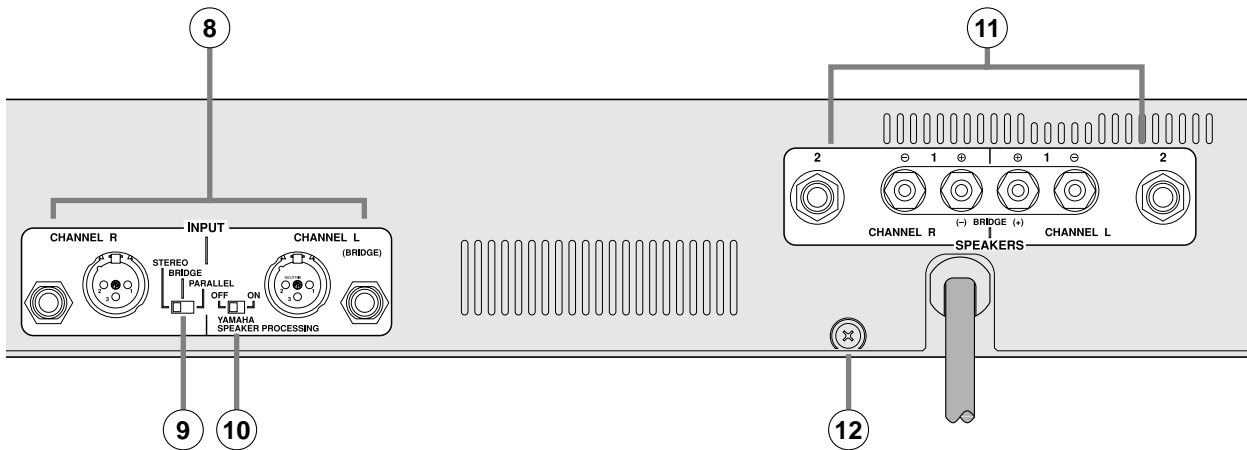

- ⑧ INPUTs
- ⑨ Mode switch
- ⑩ YAMAHA SPEAKER PROCESSING switch

- ⑪ SPEAKERS connectors
- ⑫ GND terminal

CIRCUIT BOARD LAYOUT

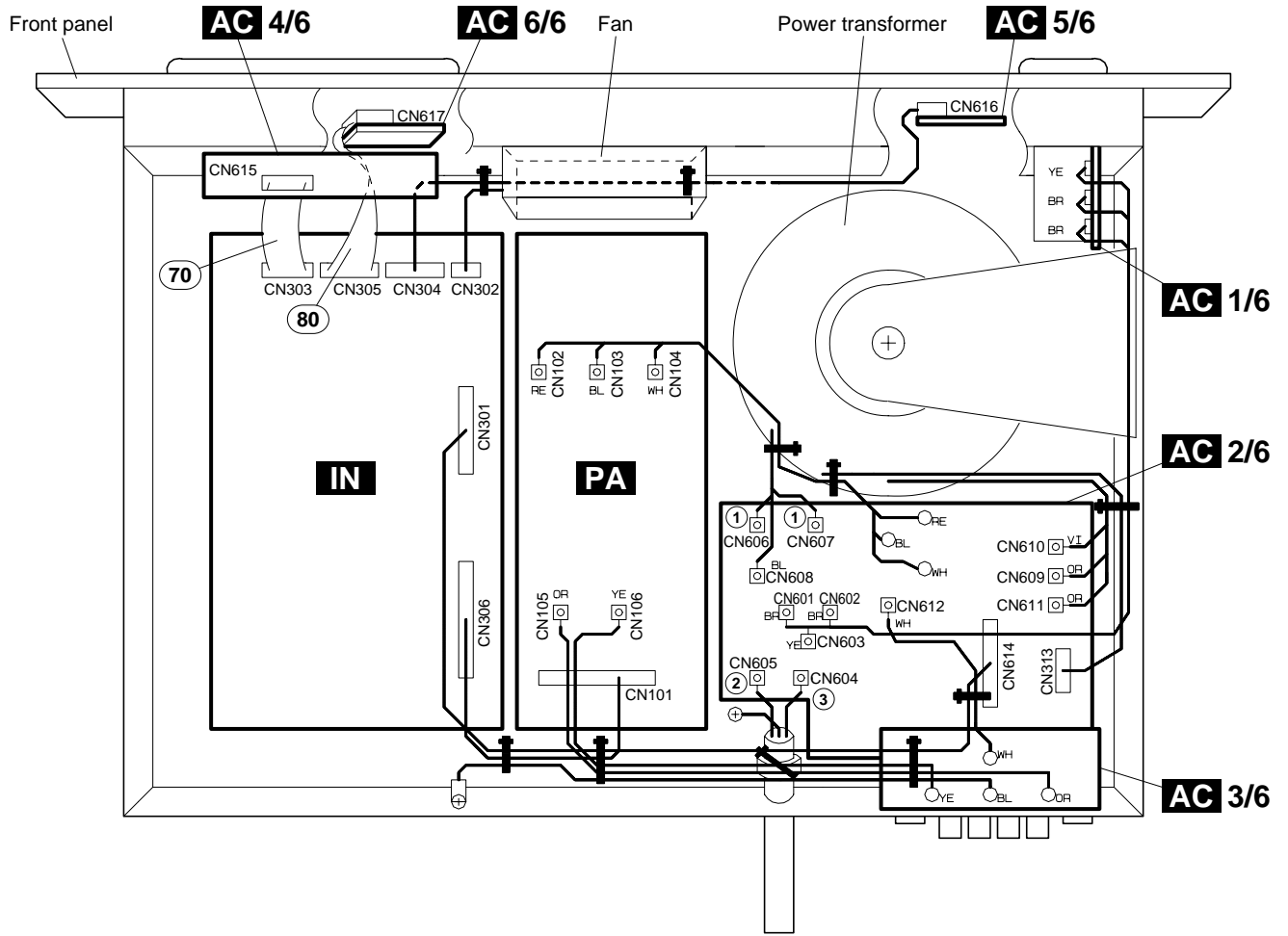

• Wire Colors

	U, V, T	H, W, B	A
①	BR	BE	RE
②	WH	BE	BE
③	BL	BR	BR

Location	Part No.	Connector Assembly	Destination		Remarks
⑦⑦	MF107100		AC 4/6-CN615	IN-CN303	7P 100mm
⑧⑧	MF109120		AC 6/6-CN617	IN-CN305	9P 120mm

WIRING

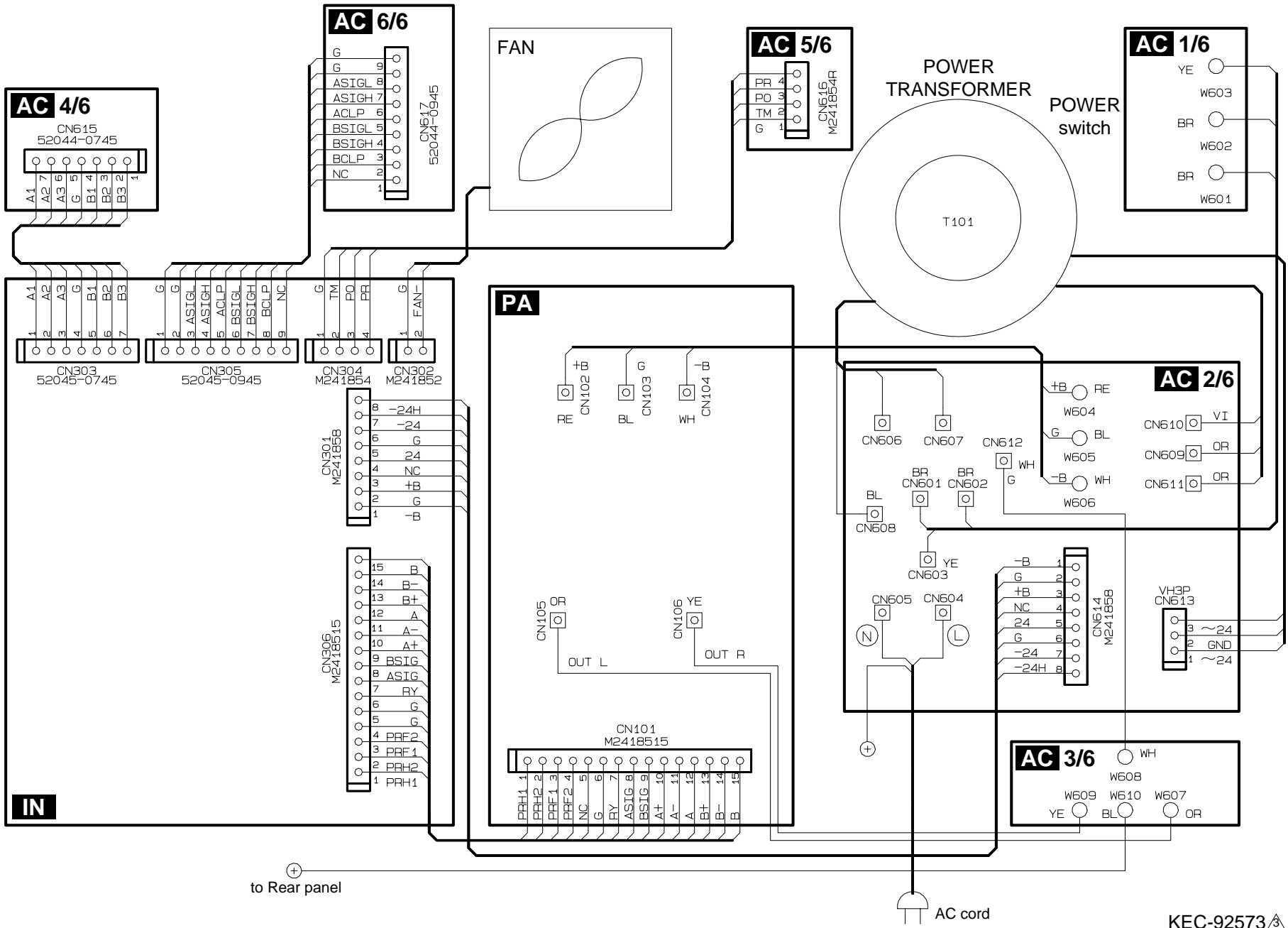

⊕
to Rear panel

⊕
AC cord

KEC-92573

■ DIMENSIONS

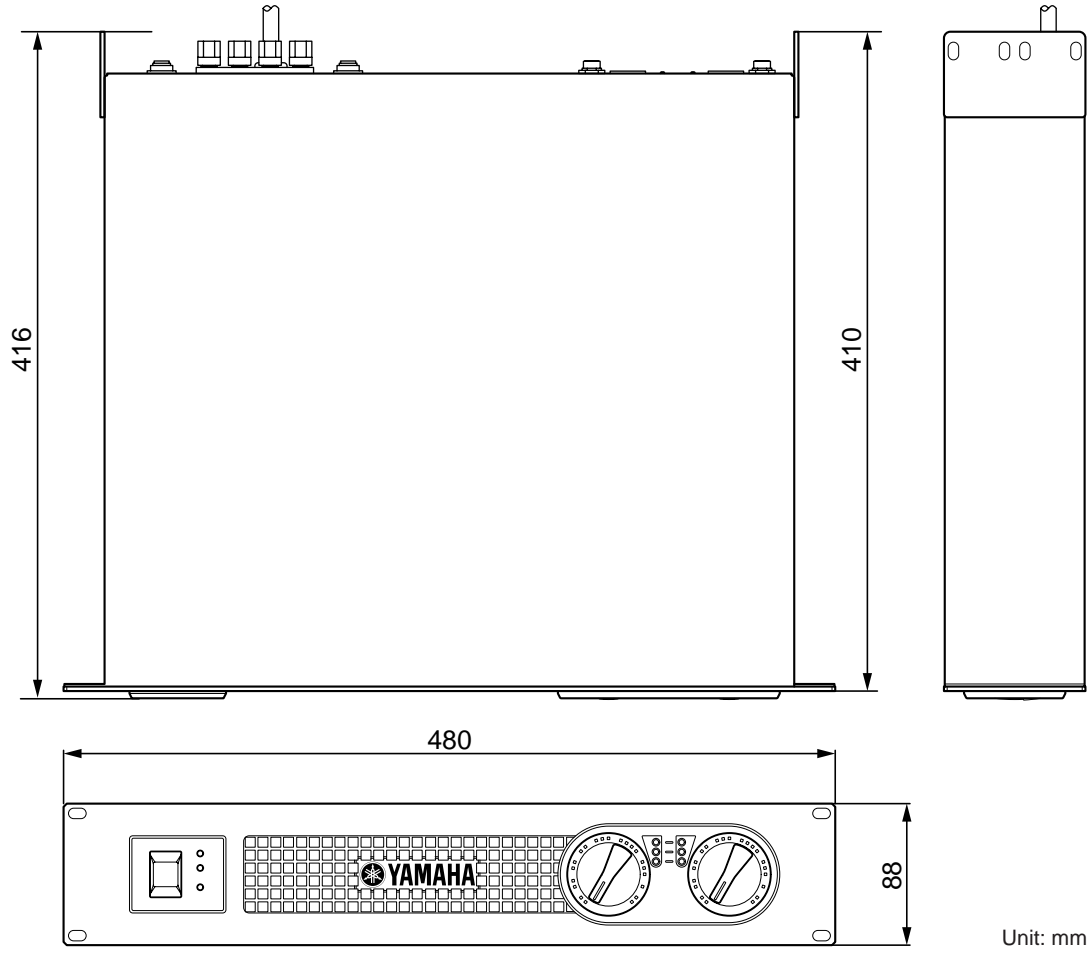

■ BLOCK DIAGRAM

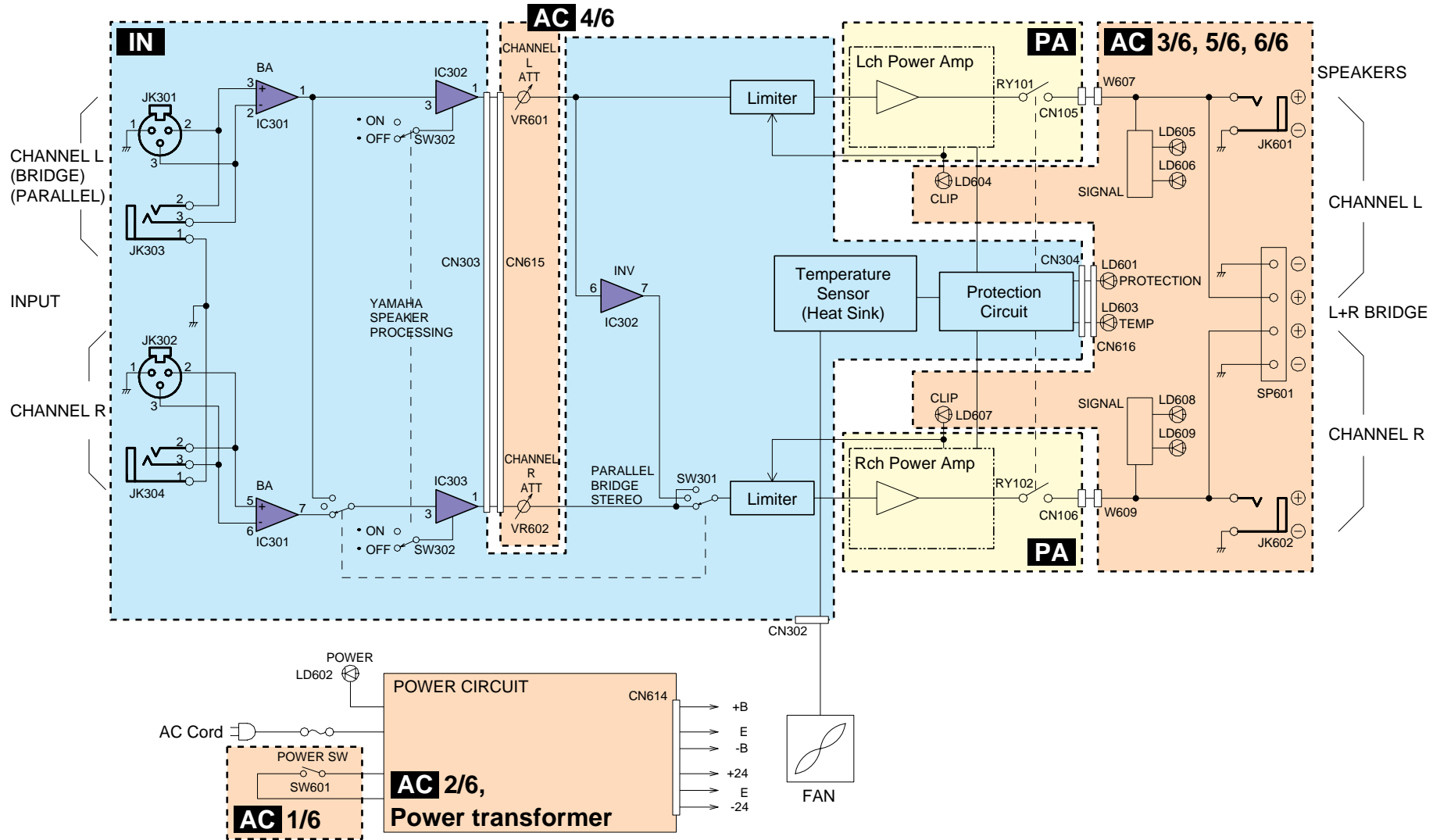

DISASSEMBLY PROCEDURE

1. Top Cover (time required: about 3 minutes)

1-1 Remove the nine (9) screws marked [420]. The top cover can then be removed. (Fig. 1)

2. IN Circuit Board (time required: about 8 minutes)

2-1 Remove the top cover. (See procedure 1.)
 2-2 Remove the six (6) screws marked [180], the four (4) screws marked [290A] and the two (2) hexagonal nuts marked [A]. The IN circuit board can then be removed. (Fig. 2, Fig. 3)

3. AC3/6 Circuit Board (time required: about 10 minutes)

3-1 Remove the top cover. (See procedure 1.)
 3-2 Remove the two (2) screws marked [320]. The speaker terminal cover can then be removed. (Fig. 3)
 3-3 Remove the screw marked [290B], the two (2) screws marked [300] and the two (2) hexagonal nuts marked [B]. The AC3/6 circuit board can then be removed. (Fig. 3)

4. AC2/6 Circuit Board (time required: about 15 minutes)

4-1 Remove the top cover. (See procedure 1.)
 4-2 Remove the AC3/6 circuit board. (See procedure 3.)
 4-3 Remove the screw marked [80A], the three (3) screws marked [120] and the two (2) screws marked [140]. The AC2/6 circuit board and the DB angle can then be removed. (Fig. 2, Fig. 4)

5. Power Transformer (time required: about 8 minutes)

5-1 Remove the top cover. (See procedure 1.)
 5-2 Remove the two (2) screws marked [103] and the hexagonal bolt marked [C]. The transformer holder and the power transformer can then be removed. (Fig. 2, Fig. 4)

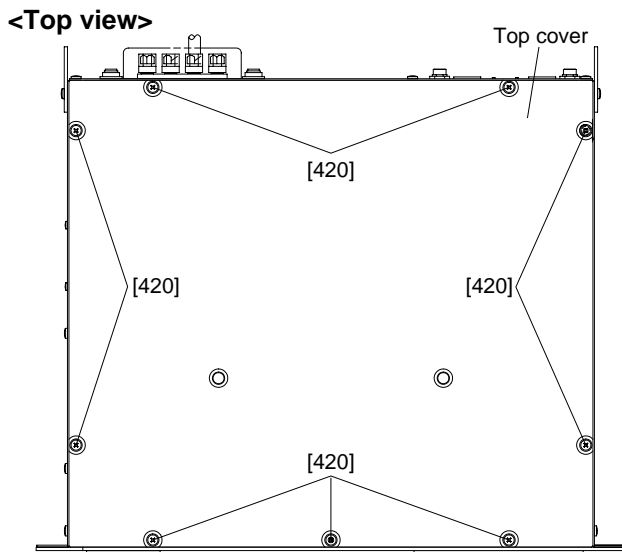

[420]: Bind Head Tapping Screw-B 4.0X8 MFZN2BL (EG340190)

(Fig. 1)

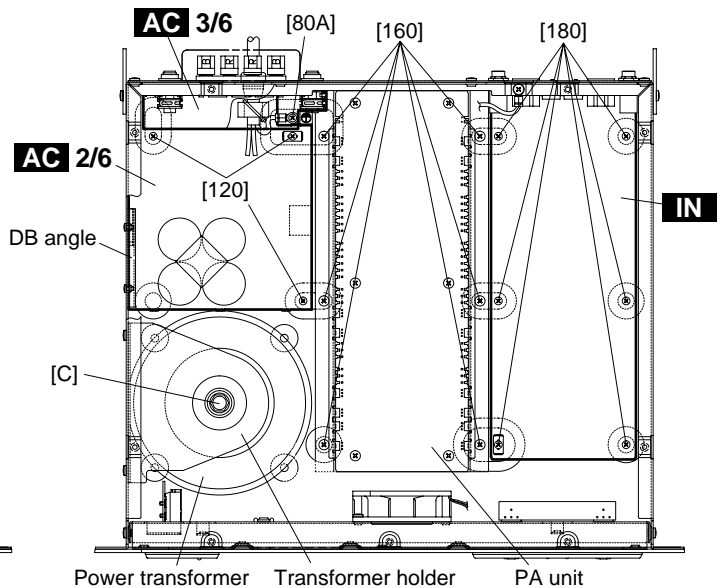

[80A]: Bind Head Screw A4.0X8 MFZN2BL (VP156800)
 [120]: Bind Head Tapping Screw-B 3.0X8 MFZN2BL (EP600190)
 [160]: Bonding Tapping Screw-B 4.0X8 MFZN2BL (VR779900)
 [180]: Bind Head Tapping Screw-B 3.0X8 MFZN2BL (EP600190)

(Fig. 2)

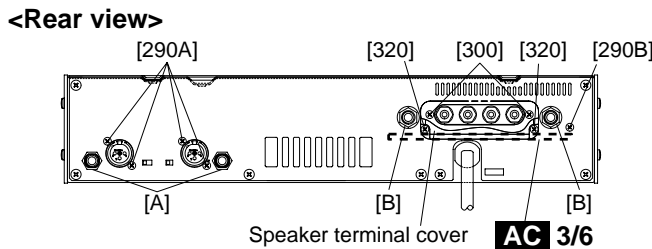

[290]: Bonding Tapping Screw-B 3.0X8 MFZN2BL (VN413300)
 [300]: Bind Head Tapping Screw-B 3.0X12 MFZN2BL (VQ074600)
 [320]: Bind Head Tapping Screw-B 3.0X8 MFZN2BL (EP600190)

(Fig. 3)

<Side view>

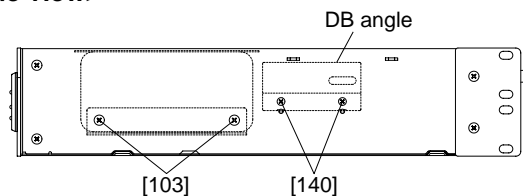

[103]: Bind Head Tapping Screw-B 4.0X8 MFZN2BL (EG340190)
 [140]: Bind Head Tapping Screw-B 3.0X8 MFZN2BL (EP600190)

(Fig. 4)

**6. PA Unit & PA Circuit Board
(time required: about 15 minutes)**

- 6-1 Remove the top cover. (See procedure 1.)
- 6-2 Remove the six (6) screws marked [160]. The PA unit can then be removed. (Fig. 2)
- 6-3 Remove the eighteen (18) screws marked [80B]. And then remove the left and right transistor holders from the PA unit. (Fig. 5)
- 6-4 Remove the six (6) screws marked [40]. And then remove the PA circuit board from the PA unit. (Fig. 5)

• PA Unit

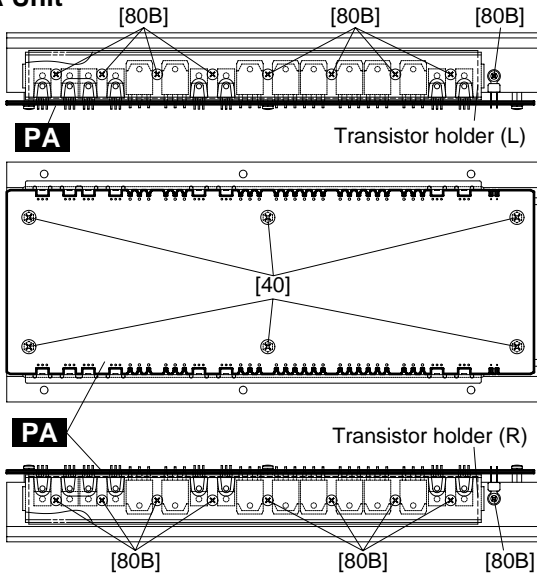

[40]: Bind Head Screw SP 3.0X8 MFZN2BL (EG330290)
 [80B]: Bind Head Tapping Screw-B 3.0X12 MFZN2BL (VQ074600)

(Fig. 5)

7. DC Fan (time required: about 8 minutes)

- 7-1 Remove the top cover. (See procedure 1.)
- 7-2 Remove the PA unit. (See procedure 6-2.)
- 7-3 Remove the two (2) screws marked [50]. The fan can then be removed. (Fig. 6)

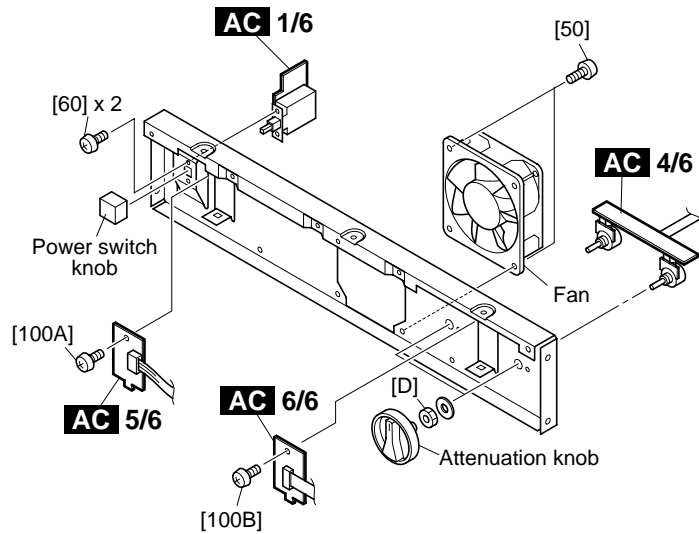

[50]: Bind Head Screw 4.0X8 MFZN2BL (EG340360)
 [60]: Bind Head Screw 3.0X8 MFZN2BL (VB659000)
 [100]: Bind Head Tapping Screw-B 3.0X8 MFZN2BL (EP600190)

(Fig. 6)

8. Front Panel (time required: about 5 minutes)

- 8-1 Remove the top cover. (See procedure 1.)
- 8-2 Remove the six (6) screws marked [250]. The front panel can then be removed. (Fig. 7)

<Front View>

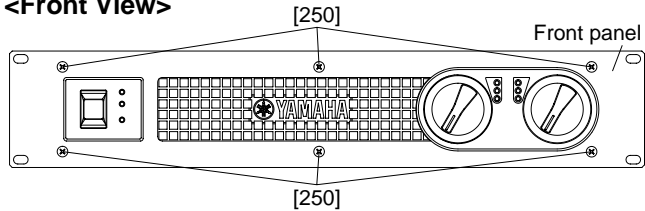

[250]: Oval Head Screw 4.0X8 MFZN2BL (VS153600)
 (Fig. 7)

**9. AC1/6, AC4/6, AC5/6 and AC6/6 Circuit Board
(time required: about 20 minutes)**

- 9-1 Remove the top cover. (See procedure 1.)
- 9-2 Remove the front panel (See procedure 8.)
- 9-3 AC1/6 Circuit Board:
 Pull out the power switch knob. (Fig. 6)
 Remove the two (2) screws marked [60]. The AC1/6 circuit board can then be removed. (Fig. 6)
- 9-4 AC4/6 Circuit Board:
 Pull out the attenuation knobs. (Fig. 6)
 Remove the two (2) hexagonal nuts marked [D]. The AC4/6 circuit board can then be removed. (Fig. 6)

- 9-5 AC5/6 Circuit Board:
 Remove the screw marked [100A]. The AC5/6 circuit board can then be removed. (Fig. 6)
- 9-6 AC6/6 Circuit Board:
 Remove the screw marked [100B]. The AC6/6 circuit board can then be removed. (Fig. 6)

■ IC BLOCK DIAGRAM

- **M5238AP** (XM085A00)
Dual Operational Amplifier
IN: IC301

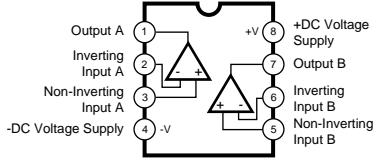

- **NJM2068L-D** (XM356A00)
Dual Operational Amplifier
IN: IC302, 303

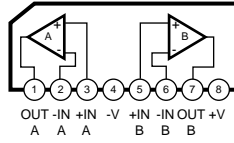

■ CIRCUIT BOARDS CONTENTS

AC 1/6 Circuit Board (XY969B0).....	12
AC 2/6 Circuit Board (XY969B0).....	16
AC 3/6 Circuit Board (XY969B0).....	13
AC 4/6 Circuit Board (XY969B0).....	12
AC 5/6 Circuit Board (XY969B0).....	12
AC 6/6 Circuit Board (XY969B0).....	12
IN Circuit Board (XY968B0)	12
PA Circuit Board (XY970B0).....	14

Note: See parts list for details of circuit board component parts.

■ CIRCUIT BOARDS

- IN Circuit Board

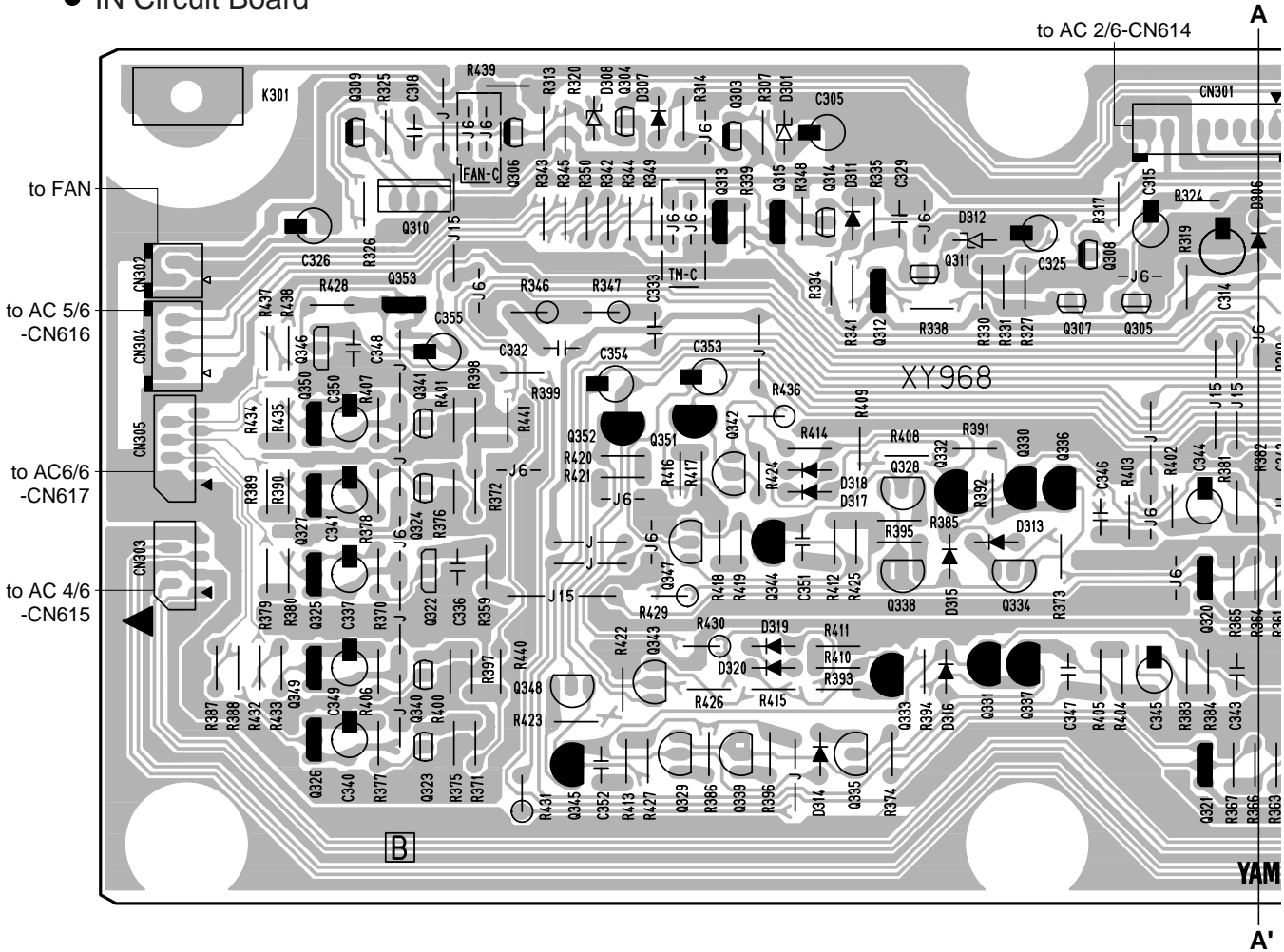

● AC 1/6 Circuit Board

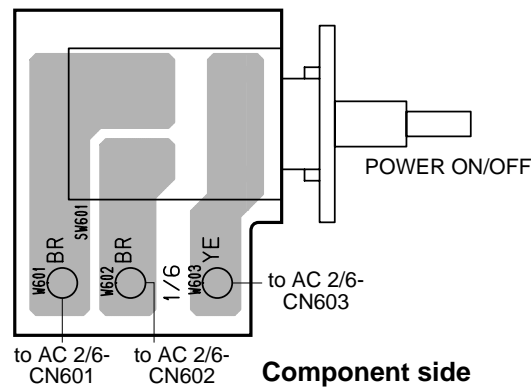

● AC 4/6 Circuit Board

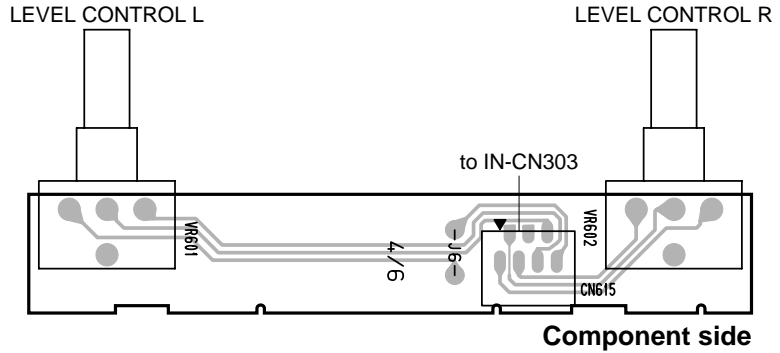

● AC 5/6 Circuit Board

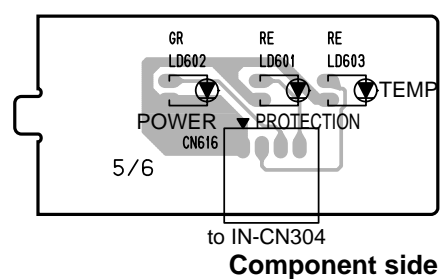

● AC 6/6 Circuit Board

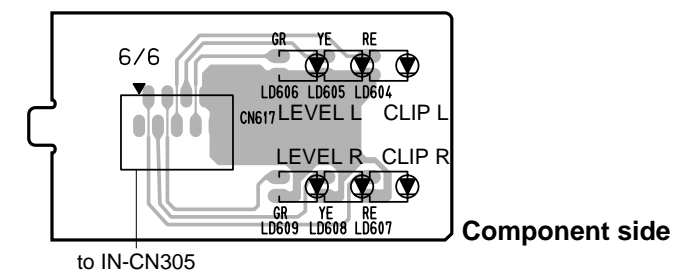

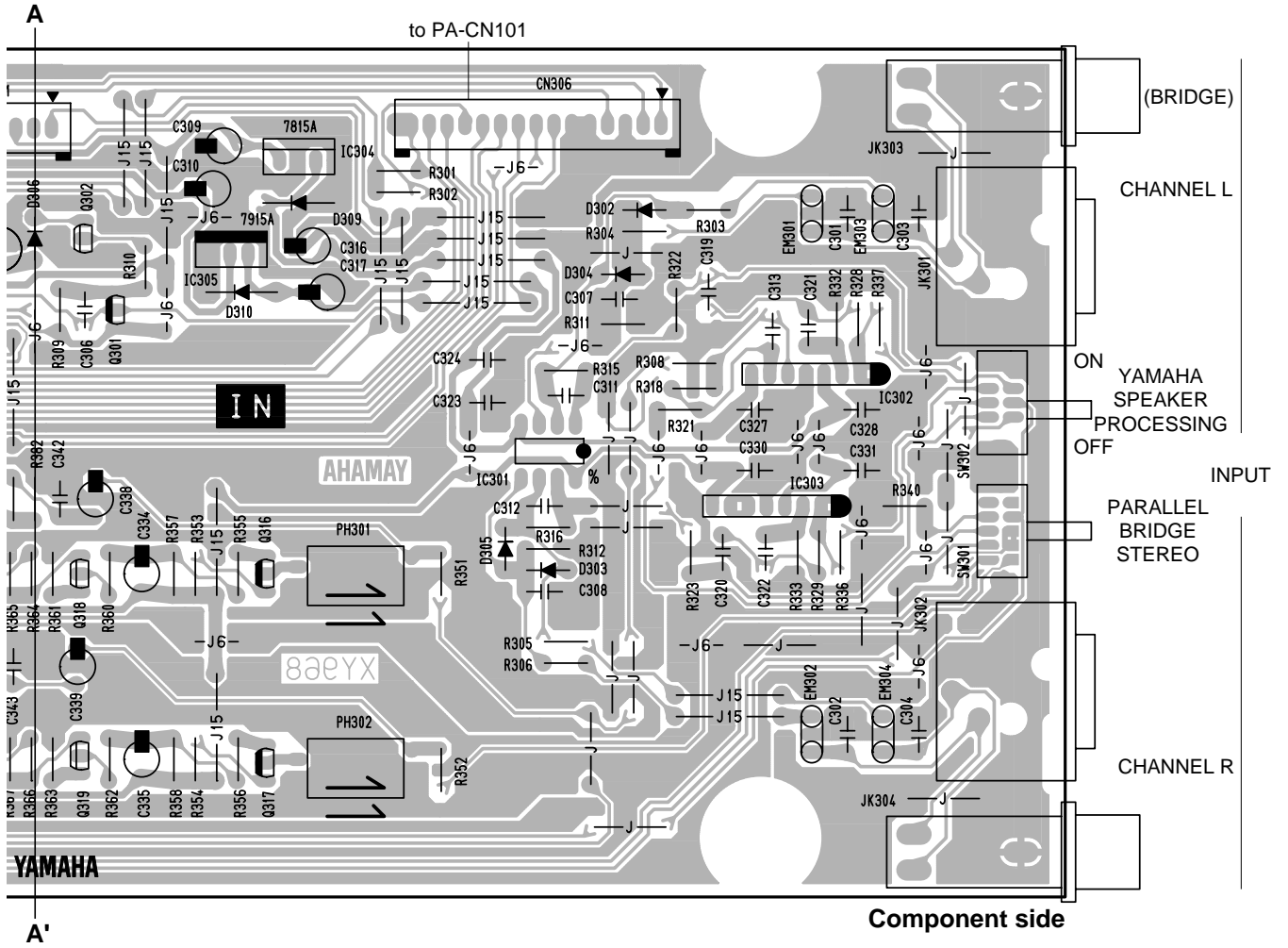

IN: 3NA-V607200 △
 AC 1/6, 4/6, 5/6, 6/6: 3NA-V607220 △

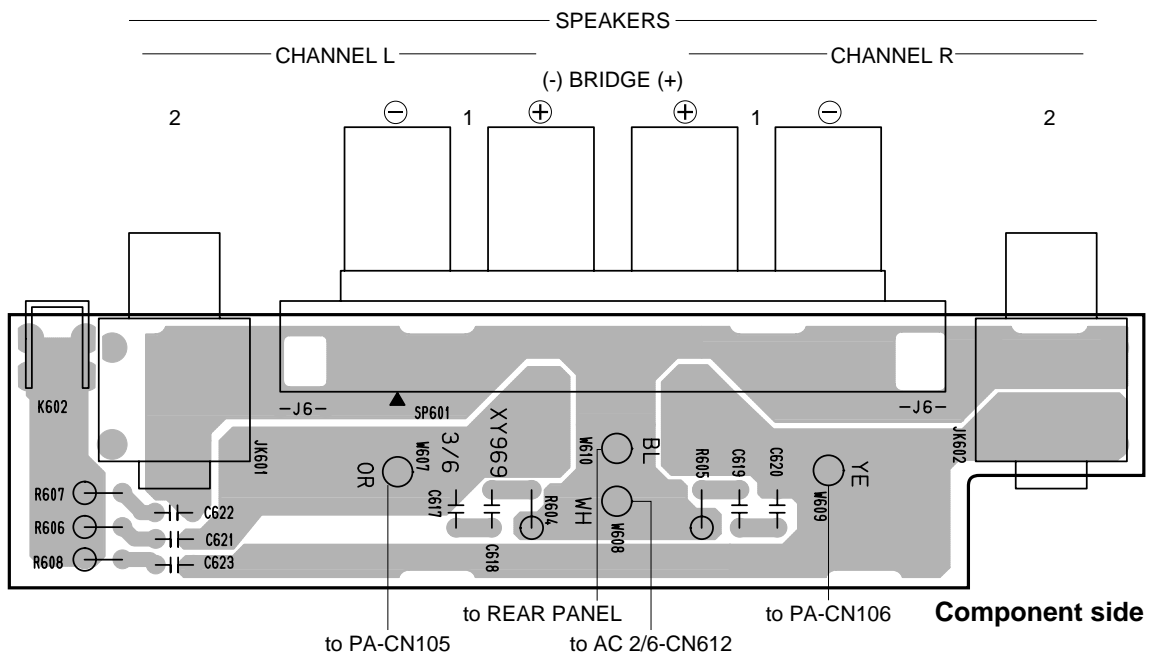

● AC 3/6 Circuit Board



IN: 3NA-V607200 
 AC 3/6: 3NA-V607220 

● PA Circuit Board

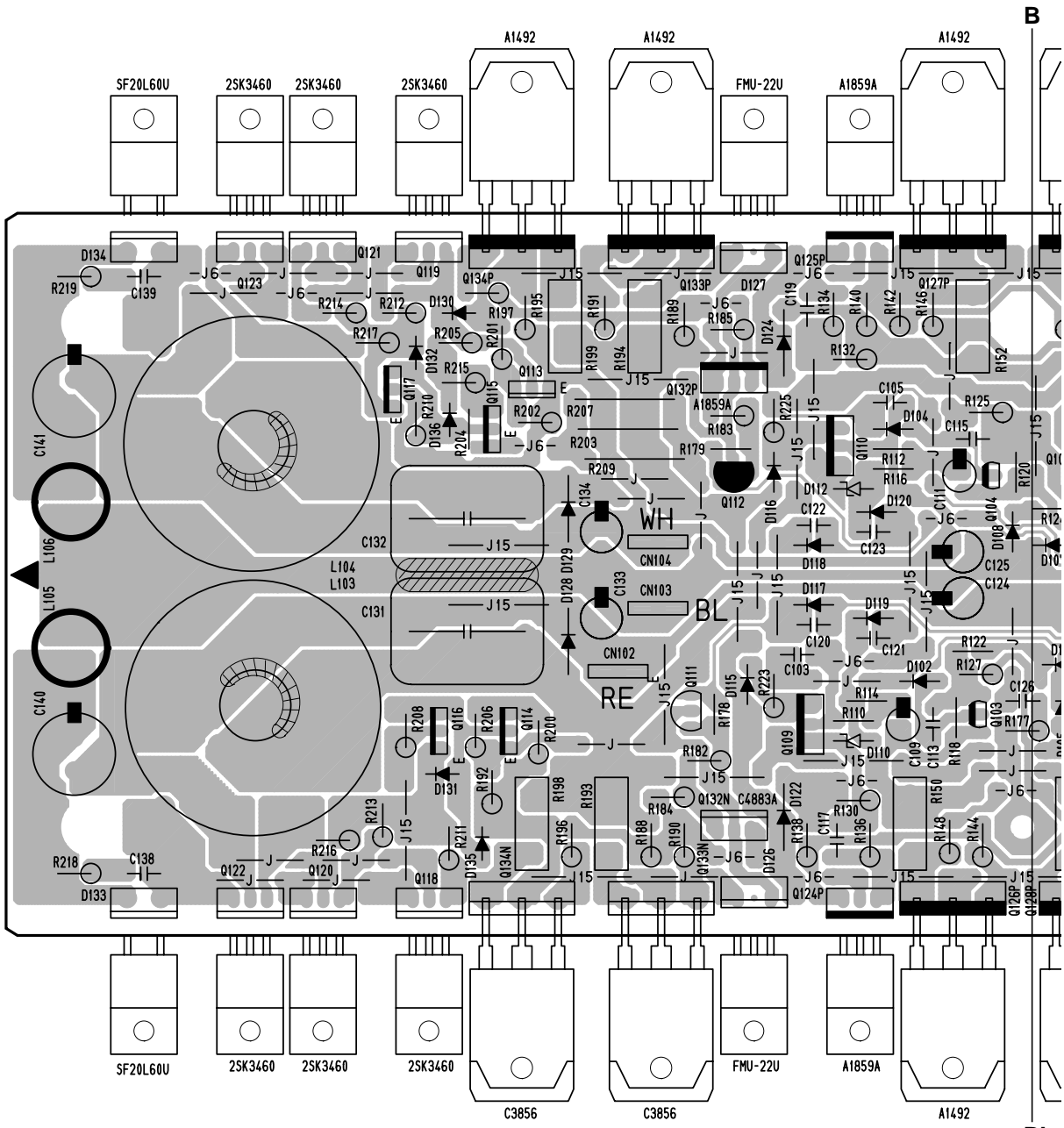

- | | | |
|-----------------------|-----------------------|-----------------------|
| CN101: to IN-CN306 | CN103: to AC 2/6-W605 | CN105: to AC 3/6-W607 |
| CN102: to AC 2/6-W604 | CN104: to AC 2/6-W606 | CN106: to AC 3/6-W609 |

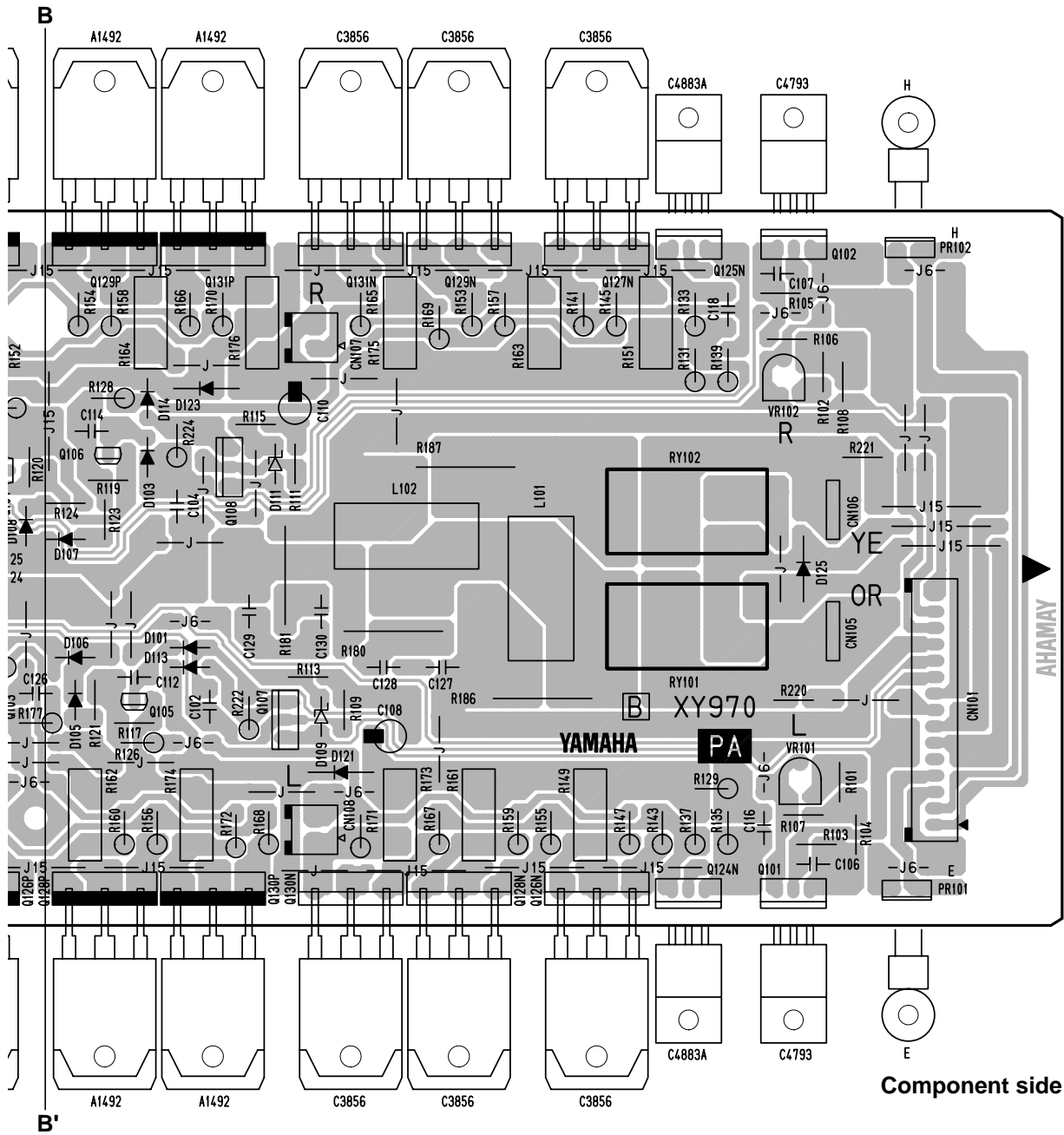

● AC 2/6 Circuit Board

to IN-CN301

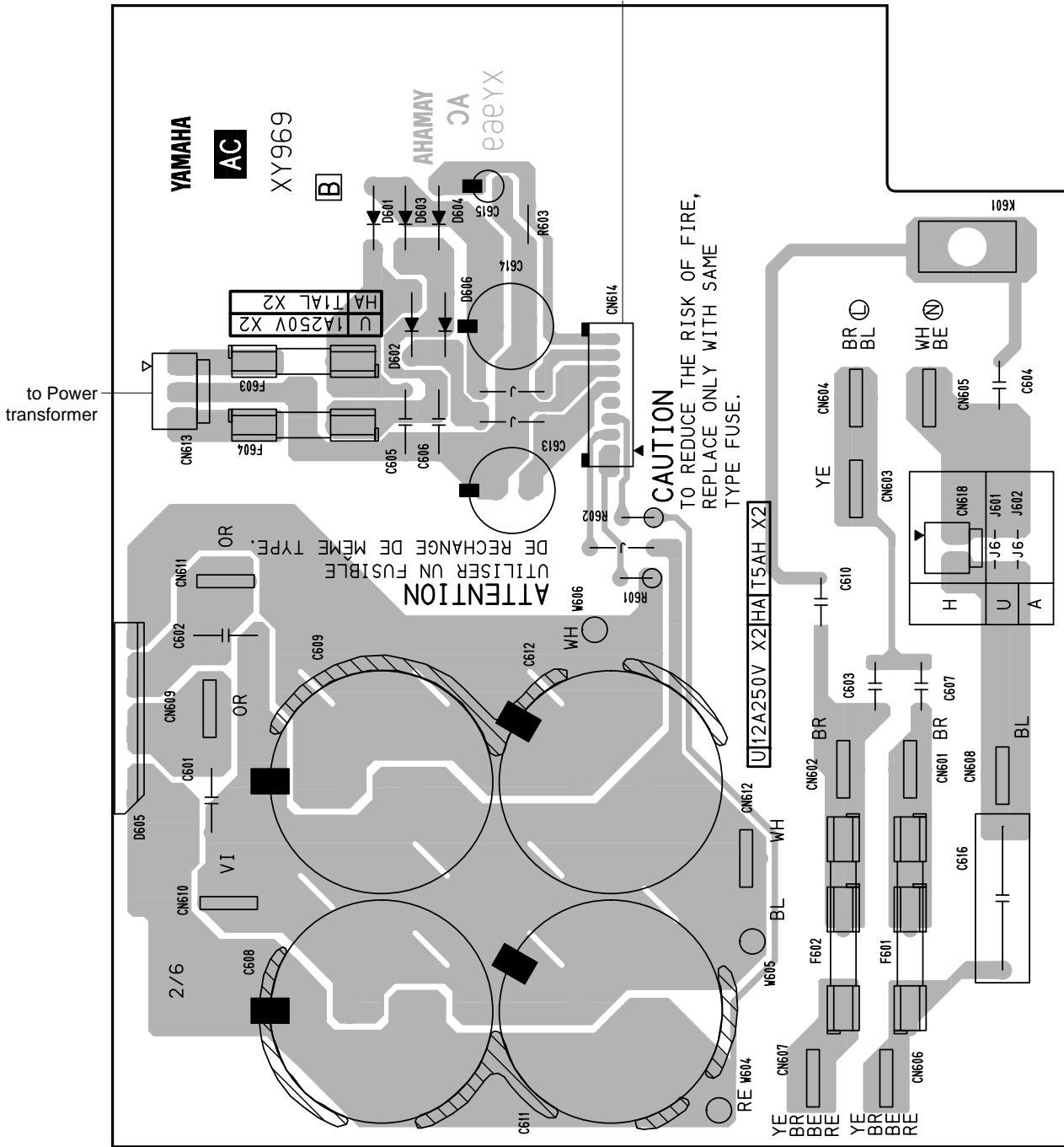

Component side

CN601: to AC 1/6-W601
 CN602: to AC 1/6-W602
 CN603: to AC 1/6-W603
 CN604: to AC cord (L)
 CN605: to AC cord (N)

CN606: to Power transformer
 CN607: to Power transformer
 CN608: to Power transformer
 CN609: to Power transformer
 CN610: to Power transformer

CN611: to Power transformer
 CN612: to AC 3/6-W608
 W604: to PA-CN102
 W605: to PA-CN103
 W606: to PA-CN104

● Wire Colors

	CN604	CN605	CN606, CN607
U, V, T	BL	WH	BR
H, W, B	BR	BE	BE
A	BR	BE	RE

■ INSPECTIONS

1. Inspection during stereo mode and parallel mode

1.1 Preparations

Input attenuator	MAX
Input terminal	Cannon connector No. 2 hot; No. 1, 3 ground
Mode SW	Stereo
Yamaha speaker processing	Off
Output terminal	Resistance load 4 Ω, Non inductance resistor, input capacitance 500 pF or more.
Others	Unless otherwise specified, drive both channels unless otherwise specified.

1.2 Inspection and adjustment

1.2.1 Fan and temperature indicator

The fan shall operate when the two jumper wires inside the frame marked FAN-C inside sheet IN are shorted. Next, the temperature indicator shall come on when the two jumper wires inside the frame marked TM-C are shorted. (Refer to the figure to the right for FAN-C, TM-C.)

<Top View>

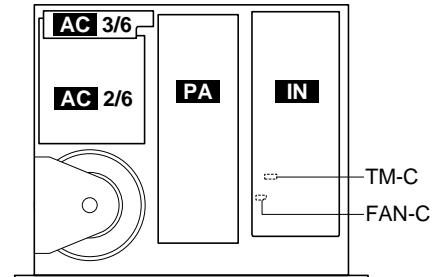

1.2.2 Power on muting time

At $t=2.5 \pm 1$ seconds after the power switch is turned on, the muting shall be cancelled and the protection indicator shall go off.

1.2.3 Idling current

Ground the input terminal and adjust VR101 (L ch) and VR102 (R ch) so that the CN108 (L ch) and CN107 (R ch) No. 1 and 2 terminals show DC voltage of $V_b=0.5 \pm 0.1$ mV.

Once all inspections have been completed, re-inspect V_b and adjust so that it is $V_b=0.5 \pm 0.1$ mV.

1.2.4 Output terminal DC voltage

Ground the input terminal and measure the V_{dc} (direct current voltage) of the output terminal. It shall be $V_{dc}=0 \pm 75$ mV.

1.2.5 Gain

An output voltage of $+24.0 \pm 0.5$ dBu shall be attained when 1 kHz, -10.0 dBu sine wave is input to the input terminal.

This inspection shall also be performed in the PARALLEL mode.

1.2.6 Frequency characteristics

* YAMAHA SPEAKER PROCESSING OFF:

Using 1 kHz as a standard for the output voltage, the output voltage shall be within -0.5 ± 0.5 dB at 20 kHz when 20 Hz, 1 kHz, 20 kHz, -10 dBu sine waves are input to the input terminal.

* YAMAHA SPEAKER PROCESSING ON:

Using 1 kHz as a standard for the output voltage, with the Yamaha speaker processing off, the output voltage shall be within $+6.5 \pm 1.5$ dB when a 70 Hz, -10 dBu sine wave is input to the input terminal.

1.2.7 Total harmonic distortion ratio characteristics

The total harmonic distortion ratio shall be $THD=1$ % or less when a 1 kHz high definition sine wave is input to the input terminal and the rated output of $650 \text{ W} + 650 \text{ W} / 4 \text{ ohm}$ (36.4 dBu/ch) has been attained. This inspection shall be completed within 30 seconds.

1.2.8 Channel separation load resistance 8 Ω

When the input terminal for one of the channels has attained a 1kHz, -5dBu sine wave and that input terminal is grounded by the introduction of 600 Ω resistance, the measured output voltage of the other channel shall be -70 dB or less, using a output voltage with (0 dB) as the reference level.

1.2.9 Output noise level

Measure the noise level at the output terminal when the input attenuator has been set to MAX and a input terminal has been grounded by the introduction of a 600 Ω resistance. It shall be -67 dBu or less. Next, set the input attenuator to MIN and measure. It shall be -70 dBu or less.

1.2.10 Stability

The following conditions shall be met when a 10 kHz, -10dBu rectangular pulse is input and a capacitance of 10 pf ~ 0.47 μF is connected in parallel with a load resistance of 4 Ω.

Overshoot $V_p/V_o \leq 1.8$

Ringings: Within 5 waves

Next, when there is only a pure capacitance of 10 pf ~ 0.47 μF the following conditions shall be met.

$V_p/V_o \leq 2.5$

Ringings: There shall be convergence within 7 waves and no oscillation, etc.

1.2.11 Protection circuit

The protection circuit shall operate and the relay shall not open when a 10 Hz, +5.4 dBu sine wave is input and the output wave is made to clip. Next, the protection circuit shall operate within two seconds and break the output when a 1 Hz, 0.0 dBu sine wave is input. In addition, when the input signal is cut, it shall automatically recover within 10 seconds.

1.2.12 Efficiency

(1) The primary electrical power shall be measured and be within the range shown below when a 1 kHz, -6.6 dBu sine wave is input to the input terminal.

$330\text{ W} \pm 50\text{ W}$ (U: $4.0\text{ A} \pm 0.6\text{ A}$, H: $2.0\text{ A} \pm 0.3\text{ A}$)

(2) The primary electrical power shall be measured and be within the range shown below when the input terminal is grounded by the introduction of the input terminal.

$25\text{ W} \pm 10\text{ W}$ (U: $0.33\text{ A} \pm 0.13\text{ A}$, H: $0.20\text{ A} \pm 0.08\text{ A}$)

1.2.13 PC limiter and comp

Input a 1 kHz, -1.5 dBu sine wave to the input terminal and connect 1 Ω (± 5 %) as a load to the output terminal. Under these conditions, a $10\text{ V} \leq V_{rms} \leq 16\text{ V}$ sine wave shall be attained at the output. The total harmonic distortion ratio shall be THD=5 % or less. Also at this time, the clip indicator shall come on. This inspection shall be completed within 30 seconds.

1.2.14 Signal indicator

The green signal indicator shall come on when a 1 kHz, -23 dBu sine wave is input.

In addition, the green and yellow signal indicators shall come on when a 1 kHz, -4 dBu sine wave is input.

2. Bridge mode

2.1 Preparations

Input attenuator	L channel only operates. Set to MAX.
Input terminal	L channel cannon connector (No. 2 hot, No. 1, 3 ground)
Mode SW	Bridge
Yamaha speaker processing	Off
Output terminal	Use L channel +, R channel +.
Load resistance	4 Ω + 4Ω, Non inductance resistor, input capacitance 500 W or more.
Measurement connection	Set to a floating ground and connect at center point of load resistance.

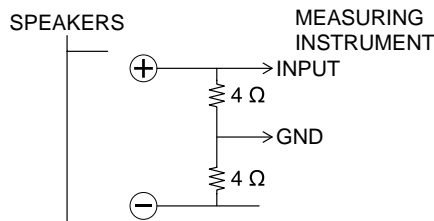

2.2 Inspection

2.2.1 Gain

An output voltage of $+24.0 \pm 1.0$ dBu shall be attained when a 1 kHz, -10 dBu sine wave is input to the input terminal.

2.2.2 Frequency characteristics

Using 1 kHz as a standard for the output voltage, the output voltage shall be within -0.5 ± 0.5 dB at 20 kHz when 20 Hz, 1 kHz, 20 kHz, -10 B dBu sine waves are input to the input terminal.

2.2.3 Total harmonic distortion ratio characteristics

The total harmonic distortion ratio shall be 1 % or less when a 1 kHz high definition sine wave is input to the input terminal and the output voltage of 36.4 dBu has been attained. This inspection shall be completed within 30 seconds.

2.2.4 Output noise level

Measure the noise level at both terminals of the load resistance when the input attenuator has been set to MAX and the input terminal has been grounded by the introduction of a 600 Ω resistance. It shall be -60 dBu or less. Next, set the input attenuator to MIN and measure. It shall be -60 dBu or less.

3. Process after completion of inspection

Close up the input attenuator in a half-clockwise direction.

Set YAMAHA SPEAKER PROCESSING to on.

Set the mode switch to STEREO.

4. Others

A DIN audio filter shall be used for the measurement of the noise level.

0 dBu=0.775 V

POWER AMPLIFIER

CP2000

PARTS LIST

■ CONTENTS



OVERALL ASSEMBLY.....	2
ELECTRICAL PARTS	5-12

Notes: DESTINATION ABBREVIATIONS

A: Australian model	M: South African model
B: British model	O: Chinese model
C: Canadian model	Q: South-east Asia model
D: German model	T: Taiwan model
E: European model	U: U.S.A. model
F: French model	V: General export model (110 V)
H: North European model	W: General export model (220 V)
I : Indonesian model	N,X: General export model
J: Japanese model	Y: Export model

■ WARNING

Components having special characteristics are marked  and must be replaced with parts having specification equal to those originally installed.

- The numbers in “QTY” show quantities for each unit.
- The parts with “- -” in “PART NO.” are not available as spare parts.
- The mark “}” in the remarks column indicates that these parts are interchangeable.
- The second letter of the shaded () part number is O, not zero.
- The second letter of the shaded () part number is I, not one.

OVERALL ASSEMBLY

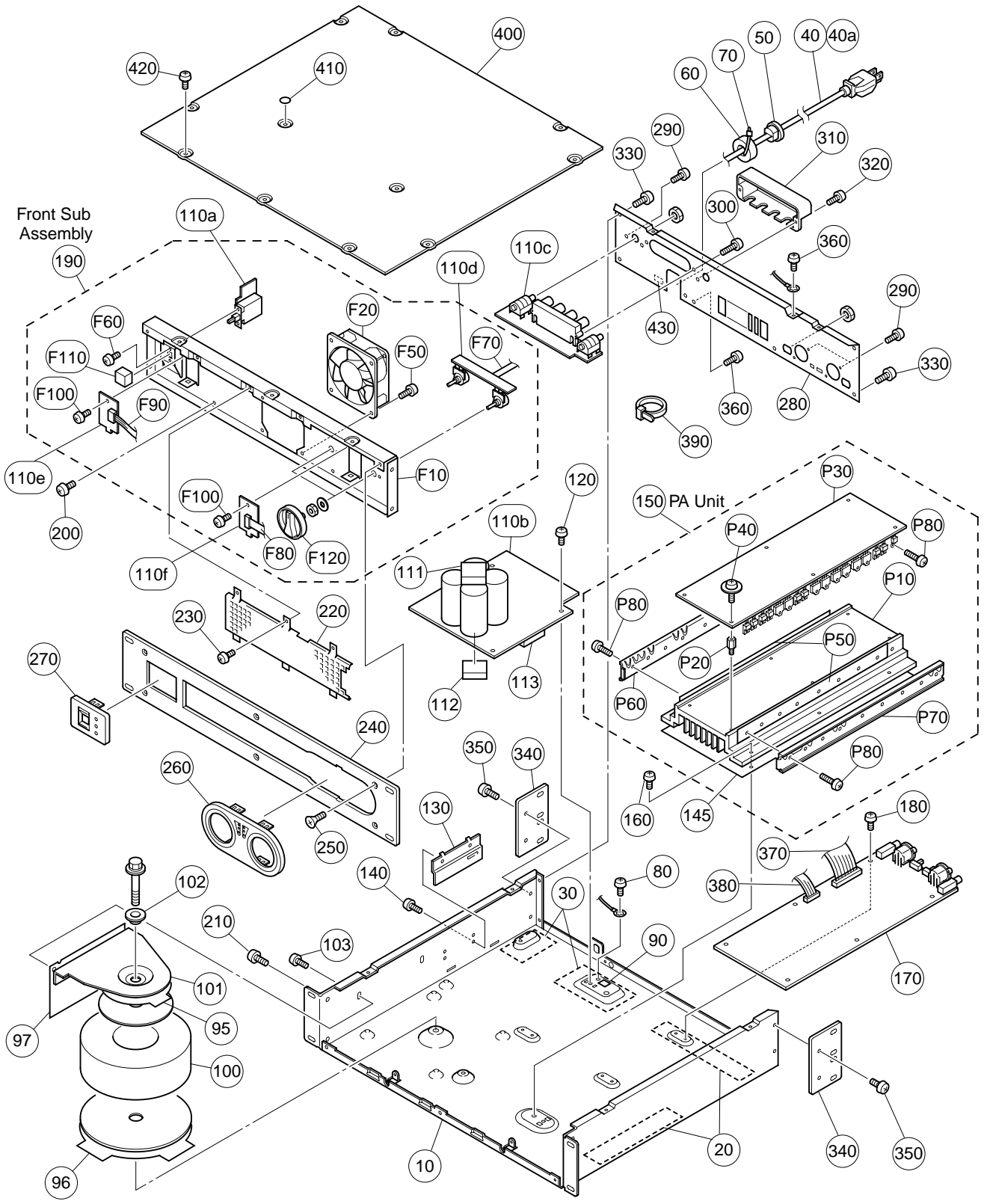

REF.NO.	PART NO.	DESCRIPTION		REMARKS	QTY	RANK
		OVERALL ASSEMBLY		CP2000		
	--	Overall Assembly		U,V (V617020)		
	--	Overall Assembly		H,W (V617030)		
	--	Overall Assembly		B (V617040)		
	--	Overall Assembly		A (V617050)		
	--	Overall Assembly		T (V617060)		
* 10	V6170900	Main Chassis		U,V,H,W,B,A		
* 10	V6308400	Main Chassis		T		
* 20	V6171000	Protection Sheet	A PPE T=0.3			2
* 30	V6171100	Protection Sheet	B PPE T=0.3			2
40	VZ021200	AC Cord	SJT 3X#18 10A	U,V		06
40	V2944000	AC Cord	H05VV-F0.75X3 6A	H,W,A		06
40	VZ021600	AC Cord	H05VV-F 13A	B		08
40	--	AC Cord Assembly		T (V245650)		
40a	VD280500	AC Cord	U 3P 15A 2.5m	T		08
50	VV103100	Cord Strain Relief	SR-6P1	U,V,H,W,B,A		01
50	VB669000	Bushing	SR-7P-2	T		02
60	V3225000	Ferrite Core	FR25/15/12-D40	H,W,B		03
70	VV104600	Cord Holder		H,W,B		01
80	VP156800	Bind Head Screw	A4.0X8 MFZN2BL			01
90	--	Label	GND	H,W,B (V542870)		
95	--	Shield sheet	A	H,W,B (V701980)		
96	--	Shield sheet	B	H,W,B (V701990)		
97	--	Shield sheet	C	H,W,B (V702000)		
* 100	XY980A00	Power Transformer	UL E	U,V,T		
* 100	XY981A00	Power Transformer	CE E	H,W,B		
* 100	XZ157A00	Power Transformer	A E	A		
* 101	V6305500	Holder, Transformer				
* 102	V6305600	Bushing	TKK			
103	EG340190	Bind Head Tapping Screw-B	4.0X8 MFZN2BL			2 01
110	--	Circuit Board	AC U	U,V,T (V607220)		
110	--	Circuit Board	AC H	H,W,B (V607230)		
110	--	Circuit Board	AC A	A (V688310)		
* 110a	AAX20810	Circuit Board	AC 1/6			
* 110b	AAX20820	Circuit Board	AC U 2/6	U,V,T		
* 110b	AAX20830	Circuit Board	AC H 2/6	H,W,B		
* 110b	AAX20840	Circuit Board	AC A 2/6	A		
* 110c	AAX20850	Circuit Board	AC 3/6			
* 110d	AAX20860	Circuit Board	AC 4/6			
* 110e	AAX20870	Circuit Board	AC 5/6			
* 110f	AAX20880	Circuit Board	AC 6/6			
* 111	V6511200	Vibration-proof Rubber	A			
* 112	V6511300	Vibration-proof Rubber	B			
* 113	V6800300	Vibration-proof Rubber	C			
120	EP600190	Bind Head Tapping Screw-B	3.0X8 MFZN2BL			3 01
130	--	DB Angle			(V617120)	
140	EP600190	Bind Head Tapping Screw-B	3.0X8 MFZN2BL			2 01
145	--	Shield sheet	D	H,W,B (V702010)		
* 150	V6170800	PA Unit				
160	VR779900	Bonding Tapping Screw-B	4.0X8 MFZN2BL			6 01
* 170	V6072000	Circuit Board	IN			
180	EP600190	Bind Head Tapping Screw-B	3.0X8 MFZN2BL			6 01
190	--	Front Sub Assembly			(V617410)	
200	EG340190	Bind Head Tapping Screw-B	4.0X8 MFZN2BL			2 01
210	VR779900	Bonding Tapping Screw-B	4.0X8 MFZN2BL			4 01
* 220	V6171300	Front Grille				
230	EP600190	Bind Head Tapping Screw-B	3.0X8 MFZN2BL			3 01
* 240	V6171400	Front Panel				
250	VS153600	Oval Head Screw	4.0X8 MFZN2BL			6 01
* 260	V6171500	Escutcheon, ATT				
* 270	V6171600	Escutcheon, PSW				
* 280	V6171700	Rear Panel		U,V		
* 280	V6171800	Rear Panel		H,W,B		
* 280	V6171900	Rear Panel		A		
* 280	V6172000	Rear Panel		T		
290	VN413300	Bonding Tapping Screw-B	3.0X8 MFZN2BL			5 01
300	VQ074600	Bind Head Tapping Screw-B	3.0X12 MFZN2BL			2 01
310	VY938700	Cover, Speaker Terminal	P-SERIES			03
320	EP600190	Bind Head Tapping Screw-B	3.0X8 MFZN2BL			2 01
330	VR779900	Bonding Tapping Screw-B	4.0X8 MFZN2BL			6 01

*: New Parts

RANK: Japan only

REF.NO.	PART NO.	DESCRIPTION		REMARKS	QTY	RANK
340	VY937100	Rear Angle	P-SERIES		2	03
350	EG340190	Bind Head Tapping Screw-B	4.0X8 MFZN2BL		4	01
360	VP156800	Bind Head Screw	A4.0X8 MFZN2BL		2	01
370	--	Connector Assembly	PA 15P	(V618590)		
380	--	Connector Assembly	AC-IN 8P	(V618600)		
390	VV104600	Cord Holder			9	01
400	VY937600	Top Cover	P-SERIES			10
* 410	V6172200	Cover	PPE T=0.3		2	
420	EG340190	Bind Head Tapping Screw-B	4.0X8 MFZN2BL		9	01
430	VA039300	Label		U,V		03
* V6170800	PA Unit					
P10	--	Heat Sink		(V617230)		
P20	VV086500	Support	H=7.4 B=5.5		6	01
* P30	V6072100	Circuit Board	PA			
P40	EG330290	Bind Head Screw	SP 3.0X8 MFZN2Y		6	01
* P50	V6172500	Insulation Sheet	TBM51W T=0.15		2	
* P60	V6172600	Transistor Holder	LEFT			
* P70	V6172700	Transistor Holder	RIGHT			
P80	VQ074600	Bind Head Tapping Screw-B	3.0X12 MFZN2BL		18	01
F10	--	Front Sub Assembly		(V617410)		
	--	Front Chassis		(V617280)		
* F20	V6622900	Fan	KDE2408PTS1-6A-318			
F50	EG340360	Bind Head Screw	4.0X8 MFZN2BL		2	01
F60	VB659000	Bind Head Screw	3.0X8 MFZN2BL		2	01
* F70	MF107100	Connector Assembly	7P 100mm P=1.25			
* F80	MF109120	Connector Assembly	9P 120mm P=1.25			
* F90	V6186100	Connector Assembly	IND 4P			
F100	EP600190	Bind Head Tapping Screw-B	3.0X8 MFZN2BL		2	01
F110	VU859000	Power Switch Knob		POWER		01
F120	VY938500	Attenuation Knob	P-SERIES	LEVEL CONTROL	2	03

*: New Parts

RANK: Japan only

ELECTRICAL PARTS

REF NO.	PART NO.	DESCRIPTION		REMARKS	QTY	RANK
		ELECTRICAL PARTS		CP2000		
	--	Circuit Board	AC U	U,V,T (V607220)(XY969C0)		
	--	Circuit Board	AC H	H,W,B (V607230)(XY969C0)		
	--	Circuit Board	AC A	A (V688310)(XY969C0)		
*	AAX20810	Circuit Board	AC 1/6	(XY969C0)		
*	AAX20820	Circuit Board	AC U 2/6	U,V,T (XY969C0)		
*	AAX20830	Circuit Board	AC H 2/6	H,W,B (XY969C0)		
*	AAX20840	Circuit Board	AC A 2/6	A (XY969C0)		
*	AAX20850	Circuit Board	AC 3/6	(XY969C0)		
*	AAX20860	Circuit Board	AC 4/6	(XY969C0)		
*	AAX20870	Circuit Board	AC 5/6	(XY969C0)		
*	AAX20880	Circuit Board	AC 6/6	(XY969C0)		
*	V6072000	Circuit Board	IN	(XY968B0)		
*	V6072100	Circuit Board	PA	(XY970B0)		
	--	Circuit Board	AC U	U,V,T (V607220)(XY969B0)		
	--	Circuit Board	AC H	H,W,B (V607230)(XY969B0)		
	--	Circuit Board	AC A	A (V688310)(XY969B0)		
*	AAX20810	Circuit Board	AC 1/6	(XY969B0)		
*	AAX20820	Circuit Board	AC U 2/6	U,V,T (XY969B0)		
*	AAX20830	Circuit Board	AC H 2/6	H,W,B (XY969B0)		
*	AAX20840	Circuit Board	AC A 2/6	A (XY969B0)		
*	AAX20850	Circuit Board	AC 3/6	(XY969B0)		
*	AAX20860	Circuit Board	AC 4/6	(XY969B0)		
*	AAX20870	Circuit Board	AC 5/6	(XY969B0)		
*	AAX20880	Circuit Board	AC 6/6	(XY969B0)		
	VV319600	Fuse Holder	CQ-05CT		8	01
	VV307300	LED Spacer			9	01
	--	Jumper Wire	0.60	(VV29140)		01
C601	V3148500	Mylar Capacitor	0.33 250V M			01
C602	V3148500	Mylar Capacitor	0.33 250V M			01
△ C603	V6113500	Capacitor	1000P 400V J.U.C.S			
△* C604	V6185400	Capacitor	3300P 400V J.U.C.S			
C605	VZ004200	Mylar Capacitor	0.1000 100V M			01
C606	VZ004200	Mylar Capacitor	0.1000 100V M			01
△ C607	V6113500	Capacitor	1000P 400V J.U.C.S			
* C608	V6183300	Electrolytic Cap.	3300 160V			
* C609	V6183300	Electrolytic Cap.	3300 160V			
△* C610	V6185400	Capacitor	3300P 400V J.U.C.S			
* C611	V6183300	Electrolytic Cap.	3300 160V			
* C612	V6183300	Electrolytic Cap.	3300 160V			
C613	V5482000	Electrolytic Cap.	1000 35.0V			
C614	V5482000	Electrolytic Cap.	1000 35.0V			
C615	UR866470	Electrolytic Cap.	4.70 50.0V			01
△* C616	VZ411400	Capacitor	0.22 275V UCS			
C617	VZ012200	Ceramic Capacitor-B	0.001 500V K			01
-620	VZ012200	Ceramic Capacitor-B	0.001 500V K			01
C621	VV314600	Ceramic Capacitor-B	0.0022 500V K			01
-623	VV314600	Ceramic Capacitor-B	0.0022 500V K			01
D601	VU801600	Diode	1N4004L 26			01
-604	VU801600	Diode	1N4004L 26			01
D605	V4833600	Diode Stack	RBV2506 25.0A 600V			04
D606	VU801600	Diode	1N4004L 26			01
△ F601	KB001540	Fuse	12.00A UL	U,V,T		04
△ F601	VT943200	Fuse	TH 5.00A S	H,W,B		01
△ F602	KB001540	Fuse	12.00A UL	U,V,T		04
△ F602	VT943200	Fuse	TH 5.00A S	H,W,B		01
△ F603	VV070300	Fuse	TDS 1A 250V J/U/C	U,V,T		01
△ F603	VV071200	Fuse	TSD 1A 250V SEMKO	H,W,B		01
△ F604	VV070300	Fuse	TDS 1A 250V J/U/C	U,V,T		01
△ F604	VV071200	Fuse	TSD 1A 250V SEMKO	H,W,B		01
K601	VZ703700	GND Plate	P-SERIES			01
K602	VV075700	Terminal Plate				01
R601	VV276700	Flame Proof C. Resistor	4.7 1/4 J			01
R602	VV276700	Flame Proof C. Resistor	4.7 1/4 J			01
R603	HF457150	Carbon Resistor	15.0K 1/4 J			01
R604	VV276700	Flame Proof C. Resistor	4.7 1/4 J			01
R605	VV276700	Flame Proof C. Resistor	4.7 1/4 J			01
R606	VZ008800	Flame Proof C. Resistor	22.0 1/4 J			01
R607	VV276700	Flame Proof C. Resistor	4.7 1/4 J			01

*: New Parts

RANK: Japan only

REF NO.	PART NO.	DESCRIPTION		REMARKS	QTY	RANK
R608	VZ008800	Flame Proof C. Resistor	22.0 1/4 J			01
RY601	VZ003600	Relay	24V			
* W601	V6186600	Connector Assembly	SWR, BR			
* W602	V6186600	Connector Assembly	SWR, BR			
* W603	V6186500	Connector Assembly	SWY, YE			
* W604	V6186300	Connector Assembly	+B, RE			
* W605	V6186200	Connector Assembly	CENT, BL			
* W606	V6186400	Connector Assembly	-B, WH			
* W607	V6185800	Connector Assembly	L, OR			
* W608	V6185500	Connector Assembly	GND, WH			
* W609	V6185700	Connector Assembly	R, YE			
* W610	V6186700	Connector Assembly	EARTH, BL			
CN601	VZ005700	Fasten Terminal	TP82223-22			01
-612	VZ005700	Fasten Terminal	TP82223-22			01
CN613	LB932030	Base Post Connector	VH- 3P TE			01
* CN614	V3764600	Connector Base Post	M24185XX 8P TE			
CN615	VQ044300	Connector, FFC	52044 7P SE			01
* CN616	V3765600	Connector Base Post	M24185XXR 4P SE			
CN617	VQ044400	Connector, FFC	52044 9P SE			01
CN618	LB932020	Base Post Connector	VH- 2P TE	H,W,B		01
JK601	VV089300	Phone Jack	H30280072N	SPEAKERS 2 LEFT		02
JK602	VV089300	Phone Jack	H30280072N	SPEAKERS 2 RIGHT		02
LD601	VV620800	LED Red	LT311G-41-C13	PROTECTION		01
LD602	VV621000	LED Green	LT321-41-C13	POWER		01
LD603	VV620800	LED Red	LT311G-41-C13	TEMP		01
LD604	VV620800	LED Red	LT311G-41-C13	ACLP		01
LD605	VV938100	LED Yellow	LT331-41-C13	ASIGH		01
LD606	VV621000	LED Green	LT321-41-C13	ASIGL		01
LD607	VV620800	LED Red	LT311G-41-C13	BCLP		01
LD608	VV938100	LED Yellow	LT331-41-C13	BSIGH		01
LD609	VV621000	LED Green	LT321-41-C13	BSIGL		01
SP601	VZ956900	Speaker Terminal	STB-403AU 4P	SPEAKERS 1		06
△ SW601	VY898100	Push Switch	SDDFA3107U-YL UCS	POWER ON/OFF		05
VR601	VI575600	Rotary Variable Resistor	5K	LEVEL CONTROL L		03
VR602	VI575600	Rotary Variable Resistor	5K	LEVEL CONTROL R		03
* -	V6072000	Circuit Board	IN	(XY968B0)		01
-	--	Jumper Wire	0.60	(VV29140)		01
C301	VZ352800	Ceramic Capacitor-SL	22P 50V J			01
-304	VZ352800	Ceramic Capacitor-SL	22P 50V J			01
C305	UR866100	Electrolytic Cap.	1.00 50.0V			01
C306	VZ353900	Ceramic Cap.-B	1000P 50V K			01
C307	VZ353300	Ceramic Capacitor-SL	56P 50V J			01
C308	VZ353300	Ceramic Capacitor-SL	56P 50V J			01
C309	UR867100	Electrolytic Cap.	10.00 50.0V			01
C310	UR867100	Electrolytic Cap.	10.00 50.0V			01
C311	VZ353300	Ceramic Capacitor-SL	56P 50V J			01
C312	VZ353300	Ceramic Capacitor-SL	56P 50V J			01
C313	VZ352800	Ceramic Capacitor-SL	22P 50V J			01
C314	VV330700	Electrolytic Cap.	470.00 10.0V			01
C315	UR847470	Electrolytic Cap.	47.00 25.0V			01
C316	UR867100	Electrolytic Cap.	10.00 50.0V			01
C317	UR867100	Electrolytic Cap.	10.00 50.0V			01
C318	VZ354000	Ceramic Capacitor-F	0.0100 50V Z			01
C319	VV062900	Mylar Capacitor	0.12 50V J			01
-322	VV062900	Mylar Capacitor	0.12 50V J			01
C323	V5868900	Mylar Capacitor	0.1 50V J			01
C324	V5868900	Mylar Capacitor	0.1 50V J			01
C325	UR867100	Electrolytic Cap.	10.00 50.0V			01
C326	UR866470	Electrolytic Cap.	4.70 50.0V			01
C327	V5868900	Mylar Capacitor	0.1 50V J			01
C328	V5868900	Mylar Capacitor	0.1 50V J			01
C329	VZ354000	Ceramic Capacitor-F	0.0100 50V Z			01
C330	V5868900	Mylar Capacitor	0.1 50V J			01
C331	V5868900	Mylar Capacitor	0.1 50V J			01
C332	VV314600	Ceramic Capacitor-B	0.0022 500V K			01
C333	VV314600	Ceramic Capacitor-B	0.0022 500V K			01
C334	UR867100	Electrolytic Cap.	10.00 50.0V			01
C335	UR867100	Electrolytic Cap.	10.00 50.0V			01
C336	VZ353900	Ceramic Cap.-B	1000P 50V K			01

*: New Parts

RANK: Japan only

REF NO.	PART NO.	DESCRIPTION		REMARKS	QTY	RANK
C337	UR866100	Electrolytic Cap.	1.00 50.0V			01
* C338	V6638400	Electrolytic Cap.	22.00 25.0V			
* C339	V6638400	Electrolytic Cap.	22.00 25.0V			
C340	UR866100	Electrolytic Cap.	1.00 50.0V			01
C341	UR866100	Electrolytic Cap.	1.00 50.0V			01
C342	FG652100	Ceramic Capacitor-SL	100P 50V J			01
C343	FG652100	Ceramic Capacitor-SL	100P 50V J			01
C344	UR828100	Electrolytic Cap.	100.00 10.0V			01
C345	UR828100	Electrolytic Cap.	100.00 10.0V			01
C346	FU451220	Mica Capacitor	22P 500V J			01
C347	FU451220	Mica Capacitor	22P 500V J			01
C348	VZ353900	Ceramic Cap.-B	1000P 50V K			01
C349	UR866100	Electrolytic Cap.	1.00 50.0V			01
C350	UR866100	Electrolytic Cap.	1.00 50.0V			01
C351	VV060300	Mylar Capacitor	2200P 50V J			01
C352	VV060300	Mylar Capacitor	2200P 50V J			01
C353	UR847100	Electrolytic Cap.	10.00 25.0V			01
C354	UR847100	Electrolytic Cap.	10.00 25.0V			01
C355	UR866100	Electrolytic Cap.	1.00 50.0V			01
* CN301	V3764600	Connector Base Post	M24185XX 8P TE			
* CN302	V3764000	Connector Base Post	M24185XX 2P TE			
CN303	VQ047100	Connector, FFC	52045 7P TE			01
CN304	V3764200	Connector Base Post	M24185XX 4P TE			
CN305	VQ047200	Connector, FFC	52045 9P TE			01
* CN306	V3765300	Connector Base Post	M24185XX 15 TE			
D301	VG440800	Zener Diode	MTZ J 15.0B 15.0V			01
D302	VD631600	Diode	1SS133,176,HSS104			01
-307	VD631600	Diode	1SS133,176,HSS104			01
D308	VG440300	Zener Diode	MTZ J 12.0C 12.0V			01
D309	VU801600	Diode	1N4004L 26			01
D310	VU801600	Diode	1N4004L 26			01
D311	VD631600	Diode	1SS133,176,HSS104			01
D312	VG437700	Zener Diode	MTZ J 5.6B 5.6V			01
D313	VD631600	Diode	1SS133,176,HSS104			01
-320	VD631600	Diode	1SS133,176,HSS104			01
EM301	V3260500	Noise Filter	ZJSR5101-271TA			01
-304	V3260500	Noise Filter	ZJSR5101-271TA			01
IC301	XM085A00	IC	M5238AP	OP AMP		03
IC302	XM356A00	IC	NJM2068L-D	OP AMP		02
IC303	XM356A00	IC	NJM2068L-D	OP AMP		02
IC304	XD853A00	IC	NJM7815FA	REGULATOR +15V		03
IC305	XD854A00	IC	NJM7915FA	REGULATOR -15V		03
JK301	VS133800	XLM Connector	NC3FAH1-0	CHANNEL L		04
JK302	VS133800	XLM Connector	NC3FAH1-0	CHANNEL R		04
JK303	VY898300	Phone Jack	ST JY6313-02-030	CHANNEL L		02
JK304	VY898300	Phone Jack	ST JY6313-02-030	CHANNEL R		02
K301	VZ703700	GND Plate	P-SERIES			01
PH301	VP116000	Photo Coupler	P873-G35-552			06
PH302	VP116000	Photo Coupler	P873-G35-552			06
Q301	V2797600	Transistor	2SA1993 E,F			01
Q302	V2797700	Transistor	2SC5395 E,F			01
Q303	V2797600	Transistor	2SA1993 E,F			01
Q304	V2797700	Transistor	2SC5395 E,F			01
Q305	V2797700	Transistor	2SC5395 E,F			01
Q306	V2797600	Transistor	2SA1993 E,F			01
Q307	V2797700	Transistor	2SC5395 E,F			01
Q308	V2797600	Transistor	2SA1993 E,F			01
Q309	V2797600	Transistor	2SA1993 E,F			01
Q310	VS883300	Transistor	2SB1565 E,F			02
Q311	V2797700	Transistor	2SC5395 E,F			01
Q312	VD678500	Digital Transistor	DTA114ES			01
Q313	VD678500	Digital Transistor	DTA114ES			01
Q314	V2797700	Transistor	2SC5395 E,F			01
Q315	VD678500	Digital Transistor	DTA114ES			01
Q316	V2797600	Transistor	2SA1993 E,F			01
Q317	V2797600	Transistor	2SA1993 E,F			01
Q318	V2797700	Transistor	2SC5395 E,F			01
Q319	V2797700	Transistor	2SC5395 E,F			01
Q320	VD678500	Digital Transistor	DTA114ES			01
Q321	VD678500	Digital Transistor	DTA114ES			01

*: New Parts

RANK: Japan only

REF NO.	PART NO.	DESCRIPTION		REMARKS	QTY	RANK
Q322	VD678700	Digital Transistor	DTC114ES			01
Q323	V2797700	Transistor	2SC5395 E,F			01
Q324	V2797700	Transistor	2SC5395 E,F			01
Q325	VD678500	Digital Transistor	DTA114ES			01
-327	VD678500	Digital Transistor	DTA114ES			01
Q328	IC1815M0	Transistor	2SC1815 Y,GR			01
Q329	IC1815M0	Transistor	2SC1815 Y,GR			01
Q330	VU418400	Transistor	2SA1371 D,E			01
-333	VU418400	Transistor	2SA1371 D,E			01
Q334	VU418600	Transistor	2SC3468 D,E			01
Q335	VU418600	Transistor	2SC3468 D,E			01
Q336	VU418400	Transistor	2SA1371 D,E			01
Q337	VU418400	Transistor	2SA1371 D,E			01
Q338	IC1815M0	Transistor	2SC1815 Y,GR			01
Q339	IC1815M0	Transistor	2SC1815 Y,GR			01
Q340	V2797700	Transistor	2SC5395 E,F			01
Q341	V2797700	Transistor	2SC5395 E,F			01
Q342	IC1815M0	Transistor	2SC1815 Y,GR			01
Q343	IC1815M0	Transistor	2SC1815 Y,GR			01
Q344	IA101590	Transistor	2SA1015 O,Y			01
Q345	IA101590	Transistor	2SA1015 O,Y			01
Q346	VD678700	Digital Transistor	DTC114ES			01
Q347	VU418600	Transistor	2SC3468 D,E			01
Q348	VU418600	Transistor	2SC3468 D,E			01
Q349	VD678500	Digital Transistor	DTA114ES			01
Q350	VD678500	Digital Transistor	DTA114ES			01
Q351	VU418400	Transistor	2SA1371 D,E			01
Q352	VU418400	Transistor	2SA1371 D,E			01
Q353	VD678500	Digital Transistor	DTA114ES			01
R301	HF458150	Carbon Resistor	150.0K 1/4 J			01
R302	HF458150	Carbon Resistor	150.0K 1/4 J			01
R303	VZ009900	Metal Film Resistor	15K 1/4 F			01
-306	VZ009900	Metal Film Resistor	15K 1/4 F			01
R307	HF456820	Carbon Resistor	8.2K 1/4 J			01
R308	VV065200	Metal Film Resistor	4.7K 1/4 F			05
R309	HF457220	Carbon Resistor	22.0K 1/4 J			01
R310	HF457470	Carbon Resistor	47.0K 1/4 J			01
R311	VZ009900	Metal Film Resistor	15K 1/4 F			01
R312	VZ009900	Metal Film Resistor	15K 1/4 F			01
R313	HF455330	Carbon Resistor	330.0 1/4 J			01
R314	HF456560	Carbon Resistor	5.6K 1/4 J			01
R315	VZ009900	Metal Film Resistor	15K 1/4 F			01
R316	VZ009900	Metal Film Resistor	15K 1/4 F			01
R317	HF457560	Carbon Resistor	56.0K 1/4 J			01
R318	VV065200	Metal Film Resistor	4.7K 1/4 F			05
R319	HF458150	Carbon Resistor	150.0K 1/4 J			01
R320	HF456820	Carbon Resistor	8.2K 1/4 J			01
R321	HF454180	Carbon Resistor	18.0 1/4 J			01
-323	HF454180	Carbon Resistor	18.0 1/4 J			01
R324	HF457100	Carbon Resistor	10.0K 1/4 J			01
R325	HF456820	Carbon Resistor	8.2K 1/4 J			01
R326	HF455220	Carbon Resistor	220.0 1/4 J			01
R327	HF457100	Carbon Resistor	10.0K 1/4 J			01
R328	VV312400	Metal Film Resistor	3.9K 1/4 F			01
R329	VV312400	Metal Film Resistor	3.9K 1/4 F			01
R330	HF457470	Carbon Resistor	47.0K 1/4 J			01
R331	HF457470	Carbon Resistor	47.0K 1/4 J			01
* R332	V5909400	Metal Film Resistor	82K 1/4 F			01
* R333	V5909400	Metal Film Resistor	82K 1/4 F			01
R334	HF457680	Carbon Resistor	68.0K 1/4 J			01
R335	HF456120	Carbon Resistor	1.2K 1/4 J			01
R336	HF454180	Carbon Resistor	18.0 1/4 J			01
R337	HF454180	Carbon Resistor	18.0 1/4 J			01
R338	HF457560	Carbon Resistor	56.0K 1/4 J			01
R339	HF457820	Carbon Resistor	82.0K 1/4 J			01
R340	VV065200	Metal Film Resistor	4.7K 1/4 F			05
R341	HF456220	Carbon Resistor	2.2K 1/4 J			01
R342	HF456120	Carbon Resistor	1.2K 1/4 J			01
-345	HF456120	Carbon Resistor	1.2K 1/4 J			01
R346	VV276700	Flame Proof C. Resistor	4.7 1/4 J			01

*: New Parts

RANK: Japan only

REF.NO.	PART NO.	DESCRIPTION		REMARKS	QTY	RANK
R347	VV276700	Flame Proof C. Resistor	4.7 1/4 J			01
R348	HF456680	Carbon Resistor	6.8K 1/4 J			01
R349	HF456120	Carbon Resistor	1.2K 1/4 J			01
R350	HF456120	Carbon Resistor	1.2K 1/4 J			01
R351	HF455330	Carbon Resistor	330.0 1/4 J			01
R352	HF455330	Carbon Resistor	330.0 1/4 J			01
R353	HF456100	Carbon Resistor	1.0K 1/4 J			01
R354	HF456100	Carbon Resistor	1.0K 1/4 J			01
R355	HF457220	Carbon Resistor	22.0K 1/4 J			01
-358	HF457220	Carbon Resistor	22.0K 1/4 J			01
R359	HF456470	Carbon Resistor	4.7K 1/4 J			01
R360	HF455330	Carbon Resistor	330.0 1/4 J			01
R361	HF456220	Carbon Resistor	2.2K 1/4 J			01
R362	HF455330	Carbon Resistor	330.0 1/4 J			01
R363	HF456220	Carbon Resistor	2.2K 1/4 J			01
R364	HF457560	Carbon Resistor	56.0K 1/4 J			01
R365	HF457220	Carbon Resistor	22.0K 1/4 J			01
R366	HF457560	Carbon Resistor	56.0K 1/4 J			01
R367	HF457220	Carbon Resistor	22.0K 1/4 J			01
R370	HF455220	Carbon Resistor	220.0 1/4 J			01
R371	HF456470	Carbon Resistor	4.7K 1/4 J			01
R372	HF456470	Carbon Resistor	4.7K 1/4 J			01
R373	HF458330	Carbon Resistor	330.0K 1/4 J			01
R374	HF458330	Carbon Resistor	330.0K 1/4 J			01
R375	HF457100	Carbon Resistor	10.0K 1/4 J			01
R376	HF457100	Carbon Resistor	10.0K 1/4 J			01
R377	HF455220	Carbon Resistor	220.0 1/4 J			01
R378	HF455220	Carbon Resistor	220.0 1/4 J			01
R379	HF456120	Carbon Resistor	1.2K 1/4 J			01
R380	HF456120	Carbon Resistor	1.2K 1/4 J			01
R381	HF457220	Carbon Resistor	22.0K 1/4 J			01
R382	V4604800	Metal Film Resistor	470.0 1/4 F			01
R383	HF457220	Carbon Resistor	22.0K 1/4 J			01
R384	V4604800	Metal Film Resistor	470.0 1/4 F			01
R385	HF455560	Carbon Resistor	560.0 1/4 J			01
R386	HF455560	Carbon Resistor	560.0 1/4 J			01
R387	HF456120	Carbon Resistor	1.2K 1/4 J			01
-390	HF456120	Carbon Resistor	1.2K 1/4 J			01
R391	HF455560	Carbon Resistor	560.0 1/4 J			01
R392	HF457100	Carbon Resistor	10.0K 1/4 J			01
R393	HF455560	Carbon Resistor	560.0 1/4 J			01
R394	HF457100	Carbon Resistor	10.0K 1/4 J			01
R395	HF455560	Carbon Resistor	560.0 1/4 J			01
R396	HF455560	Carbon Resistor	560.0 1/4 J			01
R397	HF457560	Carbon Resistor	56.0K 1/4 J			01
R398	HF457560	Carbon Resistor	56.0K 1/4 J			01
R399	HF456470	Carbon Resistor	4.7K 1/4 J			01
R400	HF457100	Carbon Resistor	10.0K 1/4 J			01
R401	HF457100	Carbon Resistor	10.0K 1/4 J			01
R402	V2440400	Metal Film Resistor	12K 1/4 F			01
R403	VV065600	Metal Film Resistor	11K 1/4 F			05
R404	V2440400	Metal Film Resistor	12K 1/4 F			01
R405	VV065600	Metal Film Resistor	11K 1/4 F			05
R406	HF455220	Carbon Resistor	220.0 1/4 J			01
R407	HF455220	Carbon Resistor	220.0 1/4 J			01
R408	HF457470	Carbon Resistor	47.0K 1/4 J			01
-411	HF457470	Carbon Resistor	47.0K 1/4 J			01
R412	HF455200	Carbon Resistor	200.0 1/4 J			01
-415	HF455220	Carbon Resistor	220.0 1/4 J			01
R416	HF457470	Carbon Resistor	47.0K 1/4 J			01
-423	HF457470	Carbon Resistor	47.0K 1/4 J			01
R424	HF455330	Carbon Resistor	330.0 1/4 J			01
-427	HF455330	Carbon Resistor	330.0 1/4 J			01
R428	HF455220	Carbon Resistor	220.0 1/4 J			01
* R429	V6252000	Flame Proof C. Resistor	470 1/4 J			01
* -431	V6252000	Flame Proof C. Resistor	470 1/4 J			01
R432	HF456120	Carbon Resistor	1.2K 1/4 J			01
-435	HF456120	Carbon Resistor	1.2K 1/4 J			01
* R436	V6252000	Flame Proof C. Resistor	470 1/4 J			01
R437	HF456120	Carbon Resistor	1.2K 1/4 J			01

*: New Parts

RANK: Japan only

REF. NO.	PART NO.	DESCRIPTION		REMARKS	QTY	RANK
R438	HF456120	Carbon Resistor	1.2K 1/4 J			01
R439	HF455330	Carbon Resistor	330.0 1/4 J			01
R440	HF457150	Carbon Resistor	15.0K 1/4 J			01
R441	HF457150	Carbon Resistor	15.0K 1/4 J			01
* SW301	VY898200	Slide Switch	SSSF123NB2-YL L=9	STEREO/BRIDGE/PARALLEL		01
* SW302	V5909200	Slide Switch	SSSF122NB2-YL L=9	SPEAKER PROCESSING ON/OFF		
* V6072100		Circuit Board	PA	(XY970B0)		01
--		Jumper Wire	0.60	(VV29140)		01
C102	FU451220	Mica Capacitor	22P 500V J			01
-105	FU451220	Mica Capacitor	22P 500V J			01
C106	VZ354000	Ceramic Capacitor-F	0.0100 50V Z			01
C107	VZ354000	Ceramic Capacitor-F	0.0100 50V Z			01
C108	UR896470	Electrolytic Cap.	4.7 100.0V			01
-111	UR896470	Electrolytic Cap.	4.7 100.0V			01
C112	VZ354000	Ceramic Capacitor-F	0.0100 50V Z			01
-115	VZ354000	Ceramic Capacitor-F	0.0100 50V Z			01
C116	VV060300	Mylar Capacitor	2200P 50V J			01
-119	VV060300	Mylar Capacitor	2200P 50V J			01
C120	V4567500	Ceramic Capacitor-SL	10P 500V K			01
-123	V4567500	Ceramic Capacitor-SL	10P 500V K			01
C124	VZ004000	Electrolytic Cap.	2.2 200.0V			01
C125	VZ004000	Electrolytic Cap.	2.2 200.0V			01
C126	VV314600	Ceramic Capacitor-B	0.0022 500V K			01
C127	VV062800	Mylar Capacitor	0.1 50V J			01
-130	VV062800	Mylar Capacitor	0.1 50V J			01
C131	V5097700	Mylar Capacitor	3.3000 250V K			05
C132	V5097700	Mylar Capacitor	3.3000 250V K			05
C133	VZ004000	Electrolytic Cap.	2.2 200.0V			01
C134	VZ004000	Electrolytic Cap.	2.2 200.0V			01
C138	VV314600	Ceramic Capacitor-B	0.0022 500V K			01
C139	VV314600	Ceramic Capacitor-B	0.0022 500V K			01
C140	VZ003800	Electrolytic Cap.	100.0 160.0V			02
C141	VZ003800	Electrolytic Cap.	100.0 160.0V			02
* CN101	V3765300	Connector Base Post	M24185XX 15 TE			01
CN102	VZ005700	Fasten Terminal	TP82223-22			01
-106	VZ005700	Fasten Terminal	TP82223-22			01
* CN107	V3764000	Connector Base Post	M24185XX 2P TE			01
* CN108	V3764000	Connector Base Post	M24185XX 2P TE			01
D101	VD631600	Diode	1SS133,176,HSS104			01
-104	VD631600	Diode	1SS133,176,HSS104			01
D105	VQ469600	Diode	HSS82			01
-108	VQ469600	Diode	HSS82			01
D109	VG438900	Zener Diode	MTZ J 8.2B 8.2V			01
D110	VG438400	Zener Diode	MTZ J 6.8C 6.8V			01
D111	VG438900	Zener Diode	MTZ J 8.2B 8.2V			01
D112	VG438400	Zener Diode	MTZ J 6.8C 6.8V			01
D113	VQ469600	Diode	HSS82			01
-120	VQ469600	Diode	HSS82			01
D121	VU801600	Diode	1N4004L 26			01
-125	VU801600	Diode	1N4004L 26			01
D126	V4816400	Diode Stack	FMU-22U 10A 200V			03
D127	V4816400	Diode Stack	FMU-22U 10A 200V			03
D128	VU801600	Diode	1N4004L 26			01
D129	VU801600	Diode	1N4004L 26			01
D130	VN478200	Diode	D1NL20U			01
D131	VN771700	Diode	D1NS4			01
D132	VN771700	Diode	D1NS4			01
* D133	V6351700	Diode	SF20L60U			01
* D134	V6351700	Diode	SF20L60U			01
D135	VN478200	Diode	D1NL20U			01
D136	VN478200	Diode	D1NL20U			01
L101	VR150900	Coil	RZ-001 21mm			02
L102	VR150900	Coil	RZ-001 21mm			02
L103	V4668300	Coil	OH-20 100uH			08
L104	V4668300	Coil	OH-20 100uH			08
L105	GD900470	Coil	RZ-001 1.5uH			01
L106	GD900470	Coil	RZ-001 1.5uH			01
PR101	VL965100	Positive Thermistor	PTH9M04BE222TS2			04
PR102	VL964800	Positive Thermistor	PTH9M04BH222TS2			04

*: New Parts

RANK: Japan only

REF NO.	PART NO.	DESCRIPTION		REMARKS	QTY	RANK
Q101	VQ547300	Transistor	2SC4793 (HFE)			03
Q102	VQ547300	Transistor	2SC4793 (HFE)			03
Q103	V2797600	Transistor	2SA1993 E,F			01
Q104	V2797600	Transistor	2SA1993 E,F			01
Q105	V2797700	Transistor	2SC5395 E,F			01
Q106	V2797700	Transistor	2SC5395 E,F			01
Q107	VR152900	Transistor	2SC3790 E,F			02
Q108	VR152900	Transistor	2SC3790 E,F			02
Q109	VR152800	Transistor	2SA1480 E,F			02
Q110	VR152800	Transistor	2SA1480 E,F			02
Q111	VU418600	Transistor	2SC3468 D,E			01
Q112	VU418400	Transistor	2SA1371 D,E			01
Q113	V4096100	Transistor	2SC4614 S,T			02
Q114	V4096000	Transistor	2SA1770 S,T			03
-117	V4096000	Transistor	2SA1770 S,T			03
* Q118	V6452100	FET	2SK3460			
* -123	V6452100	FET	2SK3460			
Q124N	VR732800	Pair Transistor	A1859A/C4883A			04
Q124P	VR732800	Pair Transistor	A1859A/C4883A			04
Q125N	VR732800	Pair Transistor	A1859A/C4883A			04
Q125P	VR732800	Pair Transistor	A1859A/C4883A			04
Q126N	VZ222300	Pair Transistor	A1492C3856(Z)(210)			06
-131N	VZ222300	Pair Transistor	A1492C3856(Z)(210)			06
Q126P	VZ222300	Pair Transistor	A1492C3856(Z)(210)			06
-131P	VZ222300	Pair Transistor	A1492C3856(Z)(210)			06
Q132N	VR732800	Pair Transistor	A1859A/C4883A			04
Q132P	VR732800	Pair Transistor	A1859A/C4883A			04
Q133N	VZ222300	Pair Transistor	A1492C3856(Z)(210)			06
Q133P	VZ222300	Pair Transistor	A1492C3856(Z)(210)			06
Q134N	VZ222300	Pair Transistor	A1492C3856(Z)(210)			06
Q134P	VZ222300	Pair Transistor	A1492C3856(Z)(210)			06
R101	HF455100	Carbon Resistor	100.0 1/4 J			01
R102	HF455100	Carbon Resistor	100.0 1/4 J			01
R103	HF456160	Carbon Resistor	1.6K 1/4 J			01
R104	HF455200	Carbon Resistor	200.0 1/4 J			01
R105	HF456160	Carbon Resistor	1.6K 1/4 J			01
R106	HF455200	Carbon Resistor	200.0 1/4 J			01
R107	HF455180	Carbon Resistor	180.0 1/4 J			01
R108	HF455180	Carbon Resistor	180.0 1/4 J			01
R109	HF457470	Carbon Resistor	47.0K 1/4 J			01
-116	HF457470	Carbon Resistor	47.0K 1/4 J			01
R117	HF456270	Carbon Resistor	2.7K 1/4 J			01
-120	HF456270	Carbon Resistor	2.7K 1/4 J			01
R121	HF457240	Carbon Resistor	24.0K 1/4 J			01
-124	HF457240	Carbon Resistor	24.0K 1/4 J			01
R125	VV313900	Flame Proof C. Resistor	680.0 1/4 J			01
-128	VV313900	Flame Proof C. Resistor	680.0 1/4 J			01
R129	VZ009300	Flame Proof C. Resistor	330.0 1/4 J			01
-132	VZ009300	Flame Proof C. Resistor	330.0 1/4 J			01
R133	VV276800	Flame Proof C. Resistor	100 1/4 J			01
-136	VV276800	Flame Proof C. Resistor	100 1/4 J			01
R137	VZ009100	Flame Proof C. Resistor	33.0 1/4 J			01
-140	VZ009100	Flame Proof C. Resistor	33.0 1/4 J			01
R141	VV276700	Flame Proof C. Resistor	4.7 1/4 J			01
-144	VV276700	Flame Proof C. Resistor	4.7 1/4 J			01
R145	VZ008800	Flame Proof C. Resistor	22.0 1/4 J			01
-148	VZ008800	Flame Proof C. Resistor	22.0 1/4 J			01
R149	V4833200	Wire Wound Resistor	0.22 5W K			
-152	V4833200	Wire Wound Resistor	0.22 5W K			
R153	VV276700	Flame Proof C. Resistor	4.7 1/4 J			01
-156	VV276700	Flame Proof C. Resistor	4.7 1/4 J			01
R157	VZ008800	Flame Proof C. Resistor	22.0 1/4 J			01
-160	VZ008800	Flame Proof C. Resistor	22.0 1/4 J			01
R161	V4833200	Wire Wound Resistor	0.22 5W K			
-164	V4833200	Wire Wound Resistor	0.22 5W K			
R165	VV276700	Flame Proof C. Resistor	4.7 1/4 J			01
-168	VV276700	Flame Proof C. Resistor	4.7 1/4 J			01
R169	VZ008800	Flame Proof C. Resistor	22.0 1/4 J			01
-172	VZ008800	Flame Proof C. Resistor	22.0 1/4 J			01
R173	V4833200	Wire Wound Resistor	0.22 5W K			

*: New Parts

RANK: Japan only

REF NO.	PART NO.	DESCRIPTION		REMARKS	QTY	RANK
-176	V4833200	Wire Wound Resistor	0.22 5W K			
R177	VV276700	Flame Proof C. Resistor	4.7 1/4 J			01
R178	HF456560	Carbon Resistor	5.6K 1/4 J			01
R179	HF456560	Carbon Resistor	5.6K 1/4 J			01
R180	V2961000	Metal Oxide Film Resistor	4.7 2W J			01
R181	V2961000	Metal Oxide Film Resistor	4.7 2W J			01
R182	VZ008800	Flame Proof C. Resistor	22.0 1/4 J			01
R183	VZ008800	Flame Proof C. Resistor	22.0 1/4 J			01
R184	VZ008700	Flame Proof C. Resistor	2.2K 1/4 J			01
R185	VZ008700	Flame Proof C. Resistor	2.2K 1/4 J			01
R186	V2961000	Metal Oxide Film Resistor	4.7 2W J			01
R187	V2961000	Metal Oxide Film Resistor	4.7 2W J			01
R188	VZ008600	Flame Proof C. Resistor	150.0 1/4 J			01
R189	VZ008600	Flame Proof C. Resistor	150.0 1/4 J			01
R190	VV313600	Flame Proof C. Resistor	2.2 1/4 J			01
R191	VV313600	Flame Proof C. Resistor	2.2 1/4 J			01
R192	VV557800	Flame Proof C. Resistor	1.0 1/4 J			01
R193	VZ370200	Wire Wound Resistor	0.1 5W K			01
R194	VZ370200	Wire Wound Resistor	0.1 5W K			01
R195	VV557800	Flame Proof C. Resistor	1.0 1/4 J			01
R196	VV313600	Flame Proof C. Resistor	2.2 1/4 J			01
R197	VV313600	Flame Proof C. Resistor	2.2 1/4 J			01
R198	VZ370200	Wire Wound Resistor	0.1 5W K			01
R199	VZ370200	Wire Wound Resistor	0.1 5W K			01
R200	VV058500	Flame Proof C. Resistor	10.0 1/4 J			01
R201	VV058500	Flame Proof C. Resistor	10.0 1/4 J			01
R202	VZ009300	Flame Proof C. Resistor	330.0 1/4 J			01
* R203	V5910300	Metal Oxide Film Resistor	3.9K 2W J			
R204	HF454220	Carbon Resistor	22.0 1/4 J			01
R205	VV313800	Flame Proof C. Resistor	220.0 1/4 J			01
R206	VZ009300	Flame Proof C. Resistor	330.0 1/4 J			01
* R207	V5910300	Metal Oxide Film Resistor	3.9K 2W J			
* R208	V6251700	Flame Proof C. Resistor	56 1/4 J			
* R209	V5910300	Metal Oxide Film Resistor	3.9K 2W J			
* R210	V6252000	Flame Proof C. Resistor	470 1/4 J			
R211	VV058500	Flame Proof C. Resistor	10.0 1/4 J			01
-217	VV058500	Flame Proof C. Resistor	10.0 1/4 J			01
R218	VV313900	Flame Proof C. Resistor	680.0 1/4 J			01
R219	VV313900	Flame Proof C. Resistor	680.0 1/4 J			01
R220	HF457120	Carbon Resistor	12.0K 1/4 J			01
R221	HF457120	Carbon Resistor	12.0K 1/4 J			01
R222	VV058500	Flame Proof C. Resistor	10.0 1/4 J			01
-225	VV058500	Flame Proof C. Resistor	10.0 1/4 J			01
RY101	VV315400	Relay	DC OSA-SH-224DM3M			06
RY102	VV315400	Relay	DC OSA-SH-224DM3M			06
VR101	VA787500	Trimmer Potentiometer	B 470 3P RHEOA			01
VR102	VA787500	Trimmer Potentiometer	B 470 3P RHEOA			01
△	VZ021200	AC Cord	SJT 3X#18 10A	U,V		06
△	V2944000	AC Cord	H05VV-F0.75X3 6A	H,W,A		06
△	VZ021600	AC Cord	H05VV-F 13A	B		08
△	VD280500	AC Cord	U 3P 15A 2.5m	T		08
△*	T101	XY980A00	Power Transformer	UL E	U,V,T	
△*	T101	XY981A00	Power Transformer	CE E	H,W,B	
△*	T101	XZ157A00	Power Transformer	A E	A	
*	V6622900	Fan	KDE2408PTS1-6A-318			

*: New Parts

RANK: Japan only

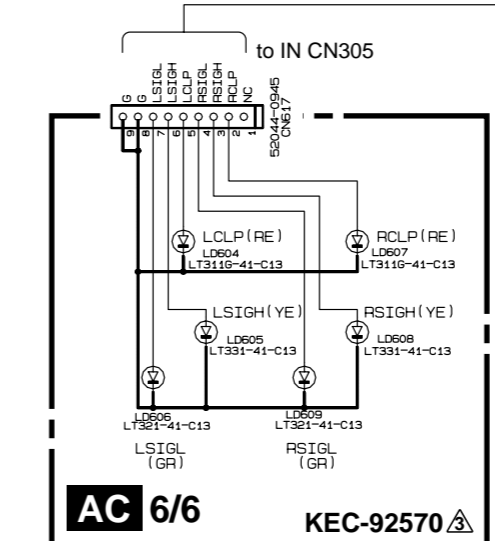
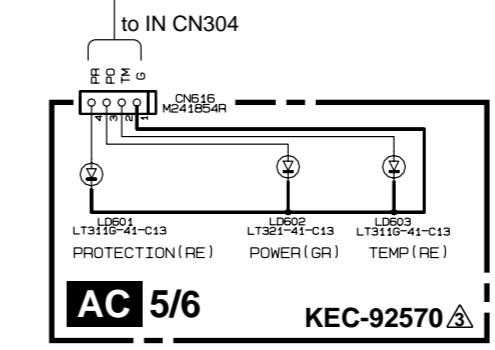
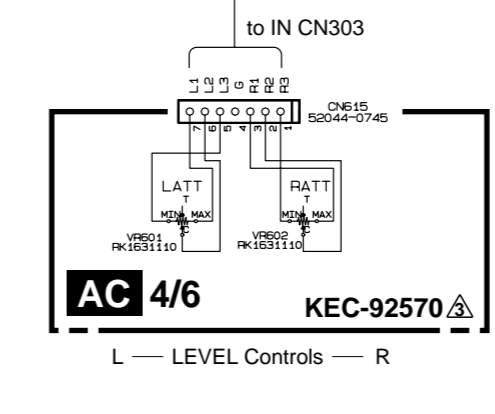
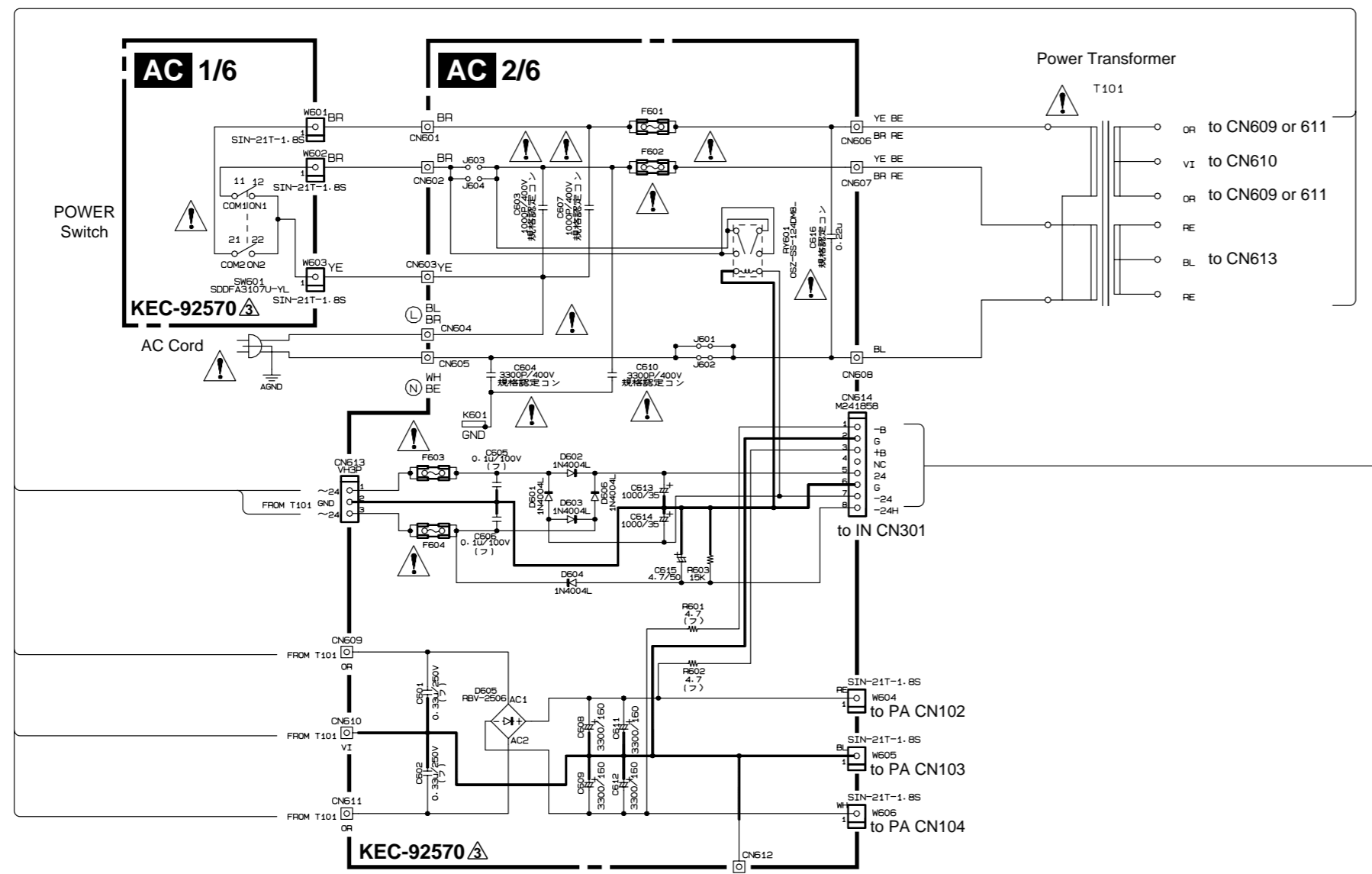
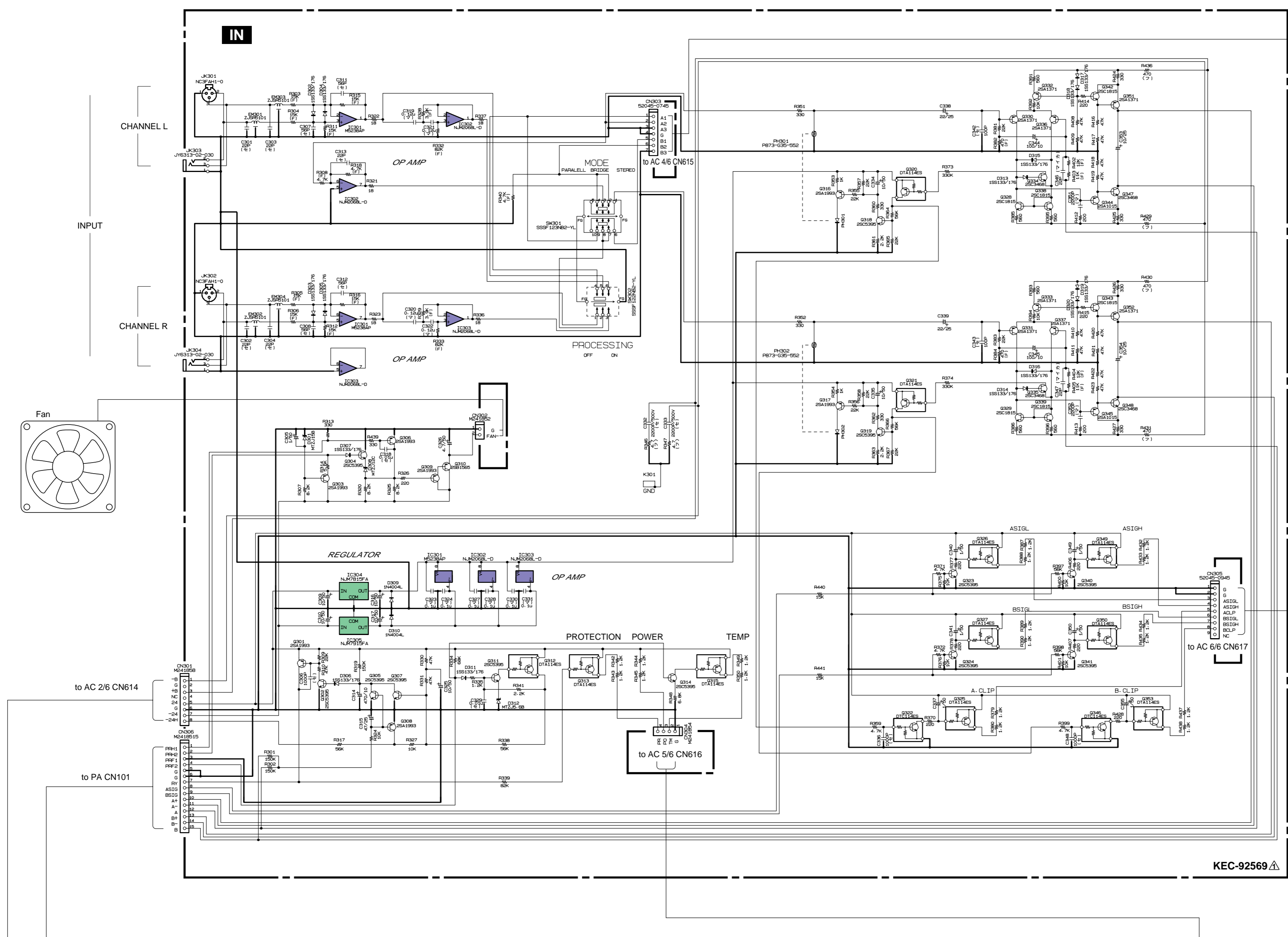

	F601	F602	F603	F604	J603,604	C604,610,616,K601	RY601	T101
U, V, T	12A 250V	12A 250V	1A 250V	1A 250V	○	○	-	XY980
H, W, B	TSAH	TSAH	T1AL	T1AL	○	○	○	XY981
A	TSAH	TSAH	T1AL	T1AL	○	○	○	XZ157

○: installed - : not installed

• Wire Colors

	CN604	CN605	CN606, CN607
U, V, T	BL	WH	BR
H, W, B	BR	BE	BE
A	BR	BE	RE

A: Australian model
 B: British model
 H: North European model
 U: U.S.A. model
 T: Taiwan model
 V: General export model (110 V)
 W: General export model (220 V)

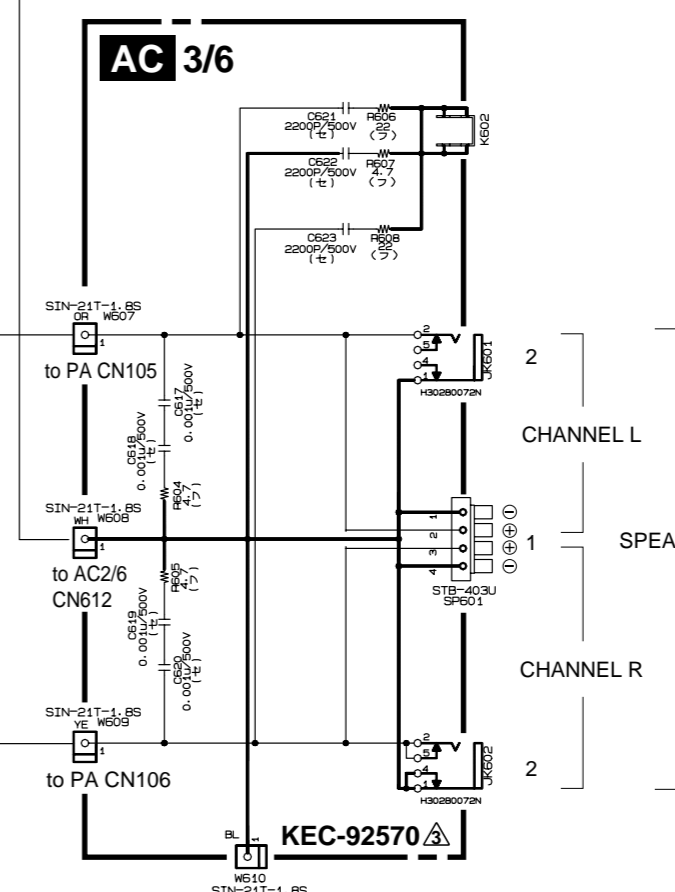
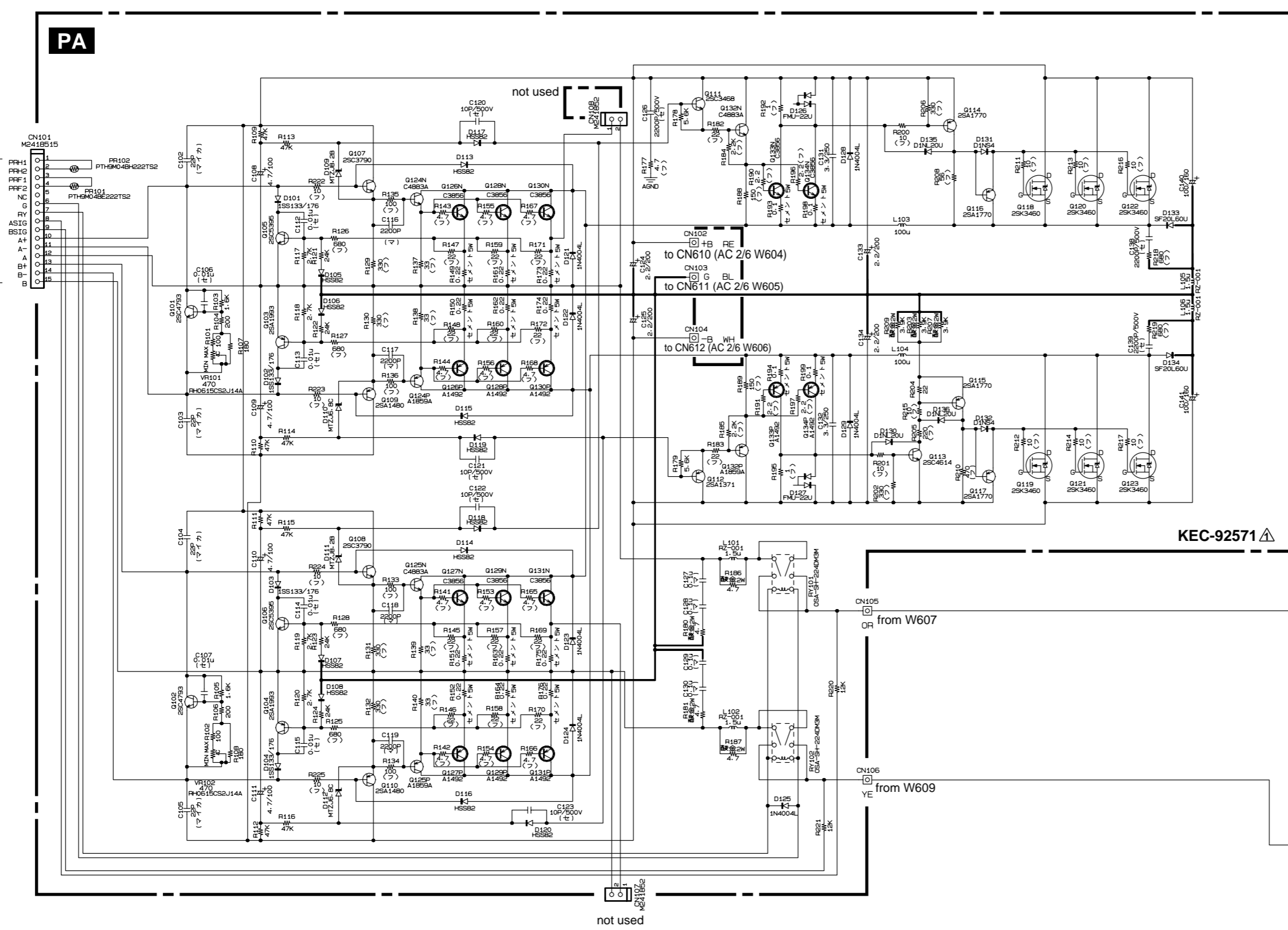

TO SERVICE PERSONNEL
 Critical Components Information
 Components having special characteristics are marked and must be replaced with parts having specifications equal to those originally installed.

Note: See parts list for details of circuit board component parts.

(半セ): Semiconductive Ceramic Capacitor
 (セ): Ceramic Capacitor
 (フ): Flame Proof Carbon Resistor
 (マ): Mylar Capacitor
 (膜金): Metal Oxide Film Resistor
 (規格認定コン): Capacitor
 (マイカ): Mica Capacitor
 (セメント): Wire Wound Resistor

