

GX-4000

STEREO TAPE DECK

OPERATOR'S MANUAL



AKAI®

MANUFACTURED & DISTRIBUTED BY AKAI ELECTRIC CO., LTD./AKAI TRADING CO., LTD./AKAI AMERICA LTD.



ALL GX (glass & single crystal ferrite) HEADS

Akai has equipped this model with its new and amazing GX Heads to bring you unequalled open reel high fidelity sound. With the symmetrical head block lay-out and dual capstan drive system of this model, an undistorted wide frequency response range covering 30,000 Hz for completely professional performance. With the GX Heads, a wider dynamic range and excellent signal-to-noise ratio are also attained. These accomplishments are contributable to head materials, superior processing technique, and a "focused-field" recording system. The core of these extraordinary heads are made of single crystal ferrite and are mounted and set in glass. This focused-field recording system minimizes high frequency loss and eliminates undue equalization for perfect recording results.

A.D.R SYSTEM

The GX-400D incorporates Akai's new and unique Automatic Distortion Reduction circuit. This circuit prevents interference and beat noise from occurring during high input recording. At input signals over 8,000 Hz where tape is easily saturated, the selective network of the A.D.R circuit is automatically activated to change the recording equalization according to input. The result is clear and distortionless high range playback over an extended frequency range.

CEE, CSA, and UL Standard models are not equipped with a Voltage Selector and Cycle Conversion Switch. Therefore, voltage and cycle conversion is not necessary. If your machine corresponds to any of these standards, please disregard all references to voltage and cycle adjustment throughout this manual.

CEE Models: 220 V, 50 Hz
CSA Models: 120 V, 60 Hz
UL Models: 120 V, 60 Hz

INDEX

Controls	2
Please read the following	
precautions before operation	4
How to load a magnetic tape	4
4-Track stereo recording and	
playback system	5
4-Track monaural recording and	
playback system	5
Automatic and manual reverse	
recording and playback	5
Tape selector switch	6
Tape speed selection	6
Direct function change control system	6
Cue switch	6
Automatic stop and shut-off	6
Pause control	6
Remote control	6
Connections for playback	7
Playback	8
Connections for recording	9
Recording	10
Echo effect	10
Sound-on-sound recording	11
Sound mixing	11
Tape erasing	11
Tape splicing and editing	11
Heads should always be kept clean	12
Pinch wheel and capstan cleaning	12
Head demagnetizing	12
Voltage and cycle conversion	13
Technical data	14
Standard accessories	14
Trouble shooting chart	15

CONTROLS

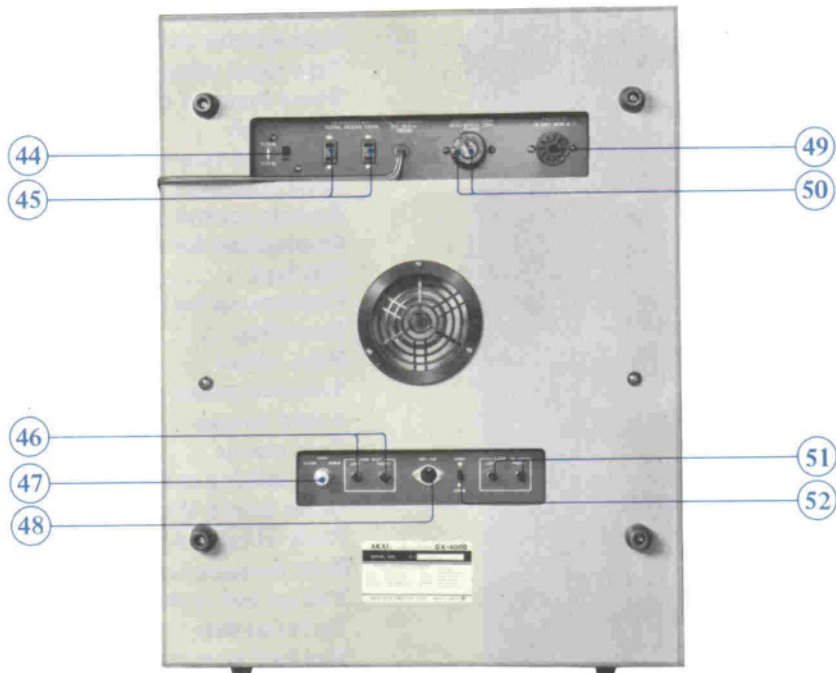
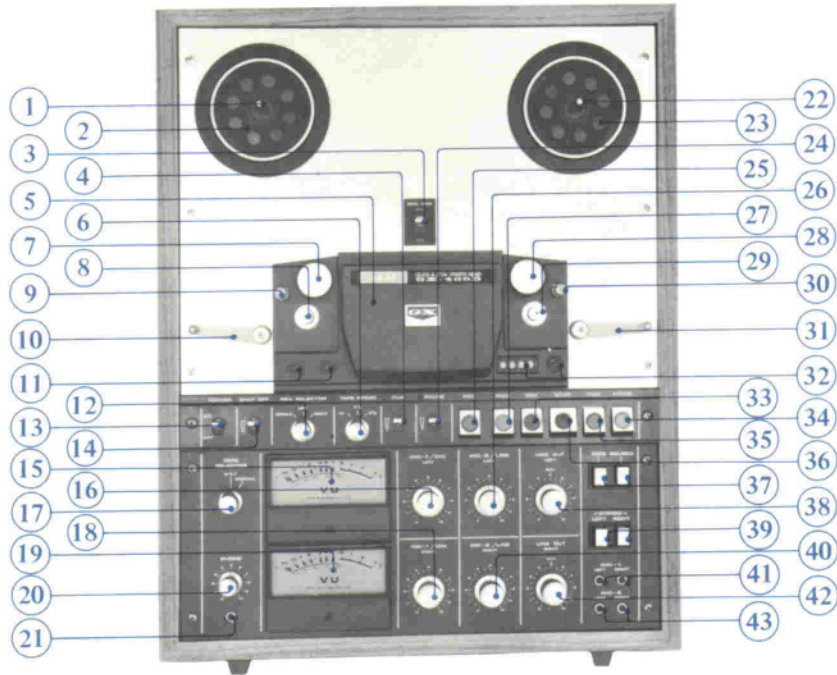

1. **BUILT-IN REEL RETAINER**
To lock reel firmly into place, pull tip of retainer outward and turn to left or right.
2. **SUPPLY REEL TABLE**
3. **REEL SIZE SELECTOR**
Set to "10 in" position when using 10-1/2" reels and to "7 in" position when using 7" or 5" reels. When using 10-1/2" reels, employ standard accessory reel adapter hubs.
4. **CUE SWITCH**
For precision cueing and editing. Refer to "Cue Switch", page 6.
5. **HEAD COVER**
Houses (from left) Reverse Playback, Reverse Recording/Erase combination, Forward Recording/Erase combination, and Forward Playback GX Heads.
6. **TAPE SPEED SELECTOR SWITCH**
Set according to desired speed. For professional high fidelity recording, 15 ips tape speed is recommended.
7. **PINCH WHEEL**
Presses against left capstan to transport tape.
* This dual capstan system provides perfect tape stability in both directions.
8. **CAPSTAN**
9. **SENSING POLE/TAPE GUIDE**
Sensing pole reverses tape direction (forward to reverse).
10. **SHUT-OFF/TENSION LEVER**
At the end of the tape when this lever drops, if the Automatic Shut-Off Switch is set to ON position, the automatic shut-off circuit is activated to cut off the power of the entire unit. Tension lever function provides proper tape tension.
11. **DIRECTION INDICATOR LAMPS**
Lights to indicate direction of capstan motor rotation.
12. **REVERSE SELECTOR SWITCH**
Refer to "Automatic and Manual Reverse Recording and Playback".
13. **POWER SWITCH**
14. **SHUT-OFF SWITCH**
Set to ON position for automatic shut-off. See item 9 above.
15. **VU METER**
Indicates left channel recording and playback levels. Normal recording is "0" VU.
16. **MIC-1/DIN INPUT LEVEL CONTROL**
Controls Mic-1 (left) and left channel Din input volume.
17. **TAPE SELECTOR SWITCH**
Set to S.R.T position when using Akai S.R.T (super range) tape or other make low noise tape. Set to NORMAL when using regular tape.
18. **MIC-1/DIN INPUT LEVEL CONTROL**
Controls Mic-1 (right) and right channel Din input volume.
19. **VU METER**
Indicates right channel recording and playback levels. Normal recording level is "0" VU.
20. **HEADPHONE VOLUME CONTROL**
Controls headphone output volume. Set Line Out Volume Control to "0" VU (position 5) and then adjust Headphone Volume Control.
21. **HEADPHONE JACK**
Accommodates any low impedance 8 Ω type stereo headphones for monitoring or headphone listening.
22. **BUILT-IN REEL RETAINER**
To lock reel firmly into place, pull tip of retainer outward and turn to left or right.
23. **TAKE-UP REEL TABLE**
24. **PAUSE SWITCH AND PAUSE INDICATOR LAMP**
Convenient for temporarily suspending tape travel during recording or playback. Pause Indicator Lamp lights to confirm pause mode.
25. **RECORDING SAFETY BUTTON**
While holding this button at depressed position, depress Forward Button to effect recording mode.
26. **MIC-2/LINE INPUT LEVEL CONTROL**
Controls Mic-2 (left) and left line input volume.
27. **REWIND BUTTON**
Rewinds tape at high speed.
28. **PINCH WHEEL**
29. **CAPSTAN**
Presses against right capstan to transport tape.
30. **TAPE GUIDE**
31. **AUTOMATIC STOP/TENSION LEVER AND SENSING POLE**
At the end of the tape, when this lever drops, if the Automatic Shut-Off Switch is at OFF position, the automatic stop circuit is activated to stop reel movement. Also functions as sensing pole for reserve to forward operation.
32. **INDEX COUNTER & RESET BUTTON**
33. **REVERSE BUTTON**
Depress to effect manual reverse (changes direction of tape from forward to reverse).
34. **FAST FORWARD BUTTON**
Advances tape of high speed.
35. **FORWARD BUTTON**
Advances tape for playback or recording mode.
36. **STOP BUTTON**
37. **MONITOR SWITCH**
Depress SOURCE Monitor Switch to monitor source during recording, and TAPE Monitor Switch for playback or private headphone listening or for monitoring recorded signals during recording mode.
38. **LINE OUTPUT LEVEL CONTROL**
Adjust left line output volume during playback.
39. **TRACK SELECTOR SWITCHES**
Left: tracks 1-4, Right: tracks 3-2, Left and Right: Stereo
40. **MIC-2/LINE INPUT LEVEL CONTROL**
Controls Mic-2 (right) and right line input volume.
41. **MIC-1 MICROPHONE JACKS**
42. **LINE OUTPUT LEVEL CONTROL**
Adjusts right line output volume at playback time.
43. **MIC-2 MICROPHONE JACKS**
44. **CYCLE CONVERSION SWITCH**
Set to 50 Hz or 60 Hz according to area power source.
45. **A.C. OUTLETS**
These extra AC outlets are unswitched (not inter-locked with the Power Switch) so that power is applied even with the GX-400D turned off.
46. **LINE OUTPUT JACKS**
Connects to tape input or aux jacks of external amplifier for playback.
47. **S.O.S./ECHO SELECTOR SWITCH**
S.O.S: For Sound-on-Sound recording. Refer to page 11.
Echo: For recording with echo effect.
Normal: Normal recording.
* Except when making an S.O.S or an echo-effect recording, this switch must always be set to NORMAL position.
48. **DIN JACK**
Enables inter-connection with an external amplifier with a single Din cord.
49. **REMOTE CONTROL SOCKET**
Accommodates Akai Remote Control Unit RC-17.
50. **UNIVERSAL VOLTAGE SELECTOR AND FUSE POST**
Offers six stages of voltage for worldwide operation. Refer to "Voltage and Cycle Conversion", page 13.
51. **LINE INPUT JACKS**
Connects to output jacks of external source.
52. **DIN JACK INPUT SELECTOR SWITCH**
When using the Din Jack, if the output level of your external amplifier is high, set this switch to HIGH, and of low, set to LOW position.

PLEASE READ THE FOLLOWING PRECAUTIONS BEFORE OPERATION

- * Your machine requires constant voltage for optimum performance. Please refer to voltage and cycle conversion procedure on page 13 if change of voltage or cycles is necessary.
- * As dirty heads and magnetized heads become the source of loss of sound, distortion, sound drop-out, and other recording and playback failures, the heads must be kept clean and demagnetized at all times.
- * Place machine on a flat level surface. Operate in either vertical or horizontal position.
- * Do not place anything on top of the unit which will obstruct the ventilator.
- * If the sound sources are so far away from the microphones that the input level controls must be turned to maximum, some hum or noise will inevitably be recorded.
A test recording is recommended before making a final recording.

- * Use good quality tape. New tape gives best results.
- * Avoid using extremely thin tape whenever possible. When the use of such tape is unavoidable, be sure to depress the Stop Button before changing modes.
- * As tapes which have not been used for a period of time may have become sticky, run tape once before using.
- * Always store tapes in a cool, dry place.

Should there be a problem with your machine, write down the model and serial numbers and all pertinent data regarding warranty coverage as well as a clear description of the existing trouble and contact your nearest authorized Akai Service Station or the Service Department of Akai Company, Tokyo, Japan.



HOW TO LOAD A MAGNETIC TAPE

1. Place a full reel of tape on the supply reel table and an empty reel on the take-up reel table.
2. Lock both reels into place by pulling tip of reel retainers outward and turning to left or right.
3. Unwind about a 85 cm length of tape from the supply reel and thread the tape as shown by the dotted lines in the figure.
4. Insert end of tape in slot of empty reel and wind around reel hub two or three times.
5. Continue winding tape onto take-up reel until all tape slack has been taken up.

When using 10-1/2" reels, place the standard accessory reel adapter hubs on left and right reel tables and lock into place by pulling tip of reel retainers outward and turning to left or right.

When using 10-1/2" metallic reels

Fit hubs over reel tables so that the white lines on the inner and outer adapter hubs are aligned and match these lines with dot on reel table (rubber bumpers of adapter will be aligned with and rest on the rubber bumpers of the reel table).

When using 10-1/2" plastic reels

Fit hubs over reel tables so that the white lines on the inner and outer adapter hubs are aligned, but do not match with dot on reel table (rubber bumpers of adapter will enter grooves between bumpers of reel table and vice-versa).

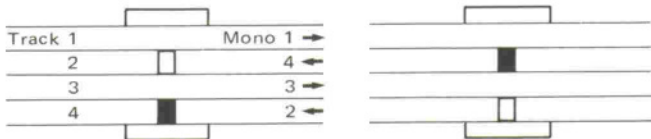
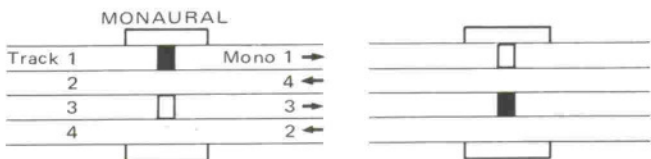
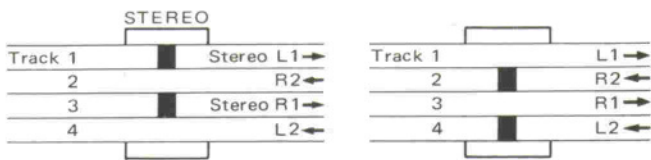

4-TRACK STEREO RECORDING AND PLAYBACK SYSTEM

4-track stereo recording and playback requires the simultaneous use of two tracks. For stereo operation, depress both Track Selector Switches. The first recording or playback takes place on tracks 1 and 3 and the second on tracks 2 and 4 after the recorder has been set to reverse mode.

4-TRACK MONAURAL RECORDING AND PLAYBACK SYSTEM

4-track monaural recording and playback sequence is 1-4-3-2. For monaural operation, depress the LEFT Track Selector Switch. The first recording or playback takes place on track 1 and second on track 4 after the recorder has been set to reverse mode. For recording or playback on track 3-2, depress the RIGHT Track Selector Switch. The third recording or playback takes place on track 3 and the fourth on track 2 after the recorder has been set to reverse mode.

* As this model records in reverse direction, it is not necessary to invert reels.

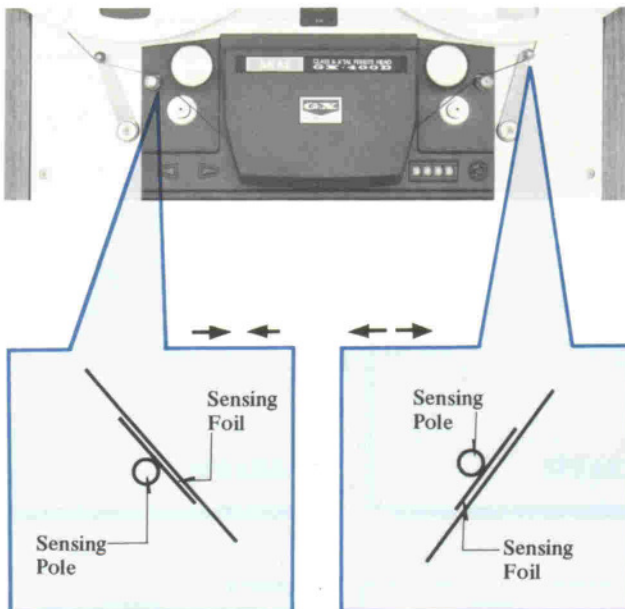

AUTOMATIC AND MANUAL REVERSE RECORDING AND PLAYBACK

For automatic reverse recording or playback (from forward to reverse direction), affix about a 2.5 cm (1") long piece of metallic sensing foil to the outside of the magnetic tape at desired reversing point. If continuous reverse between two points is desired, affix another piece of sensing foil to the inside of the magnetic tape at desired reversing point. As the sensing foil passes the sensing poles, reverse is effected depending upon the position of the Reverse Selector.

Single cycle reverse

Set Reverse Selector Switch to SINGLE position. The tape will record (playback) one forward and reverse cycle and then automatically stop.

Non-reverse

Set Reverse Selector Switch to OFF position. Recording (playback) will be effected in one direction only. At this setting, one-way recording or playback will be effected whether or not sensing foil is applied to the tape.

Continuous reverse

Set Reverse Selector Switch to CONT position. Recording (playback) will continue in both directions until the Stop Button is depressed.

* When manual operation of any of these functions is desired, operate the Reverse Button.

TAPE SELECTOR SWITCH

This model is equipped with a Tape Selector Switch. Use of this switch brings out the maximum response of high performance low noise tapes and works to change the recording equalization according to the tape. The combination of Akai GX Heads and low noise tape has enabled startling progress in tone quality.

* When low noise tape is not being used, this switch must be set to NORMAL position.

TAPE SPEED SELECTION

This model can be operated at 15, 7-1/2, or 3-3/4 ips tape speed. Simply depress Tape Speed Selector Switch according to desired speed. Recording time with an 1,800 ft. tape is as follows: (stereo) 3 hrs at 3-3/4 ips; 1.5 hrs. at 7-1/2 ips; 45 min. at 15 ips.

* For professional recording, 15 ips tape speed is recommended.

DIRECT FUNCTION CHANGE CONTROL SYSTEM

This model employs a direct function change control system for speedy mode selection. The necessity of depressing the Stop Button before changing modes is eliminated. Further the controls are equipped with individual colored lights which indicate each operating mode.

* The use of extremely thin tape should be avoided. When the use of such tape is absolutely necessary, it is recommended that the Stop Button be depressed before changing operating modes.

CUE SWITCH

The Cue Switch facilitates precision cueing and editing. When the switch is set to ON position during fast forward or rewind, a "tweeting" sound can be heard where there are recordings on the tape. Where there are no recordings, or at the blank space between recordings, no sound is audible. After stopping tape at desired position, move reels while listening to the sound, so that the correct location is obtained.

* When using the Cue Switch the TAPE Monitor Switch must be at depressed position.

AUTOMATIC STOP AND SHUT-OFF

One of the exclusive features of this model is the Automatic Stop/Shut-Off function of the unit.

Automatic Stop

At the end of the tape, the automatic stop circuit is activated and reel movement is stopped.

Automatic Shut-Off

For automatic shut-off, set the Automatic Shut-Off Switch in direction of the arrow. At the end of the tape, the shut-off circuit is activated and the power of the entire unit is cut off.

PAUSE CONTROL

This model is equipped with a Pause Switch for momentarily stopping tape travel during recording or playback. This feature is especially convenient for editing tapes. Simply set Pause Switch in direction of the arrow when a certain portion of the program is not desired. Note that the Pause Indicator Lamp will light to confirm pause mode. Return Pause Switch to normal position to resume recording.

REMOTE CONTROL

All operating functions of this model can be remote controlled by using Akai Remote Control unit RC-17 optional accessory. Plugs into Remote Control Socket on rear panel.

CONNECTIONS FOR PLAYBACK



The Din Jack of the GX-400D can be used instead of the Line Output Jacks for connection with the external stereo amplifier. This enables playback or recording with a single connection cord.

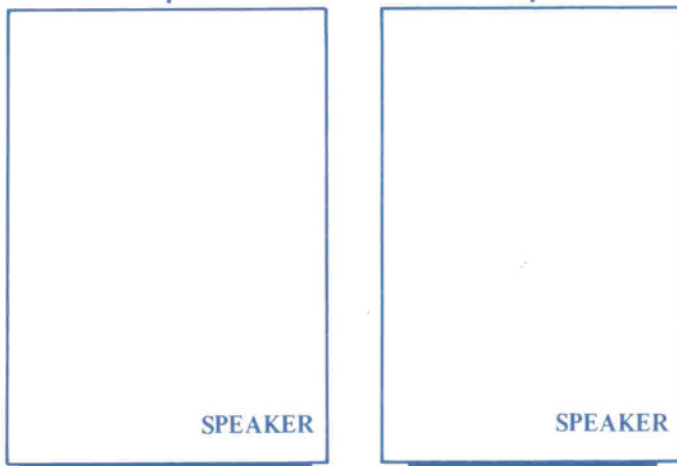
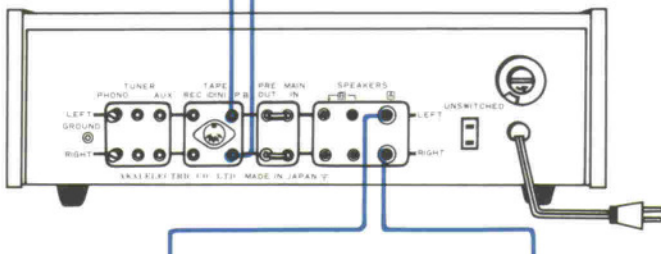

RCA/RCA plug connection cord



DIN/DIN plug connection cord



For private headphone listening, use stereo headphones of 8 Ω impedance.

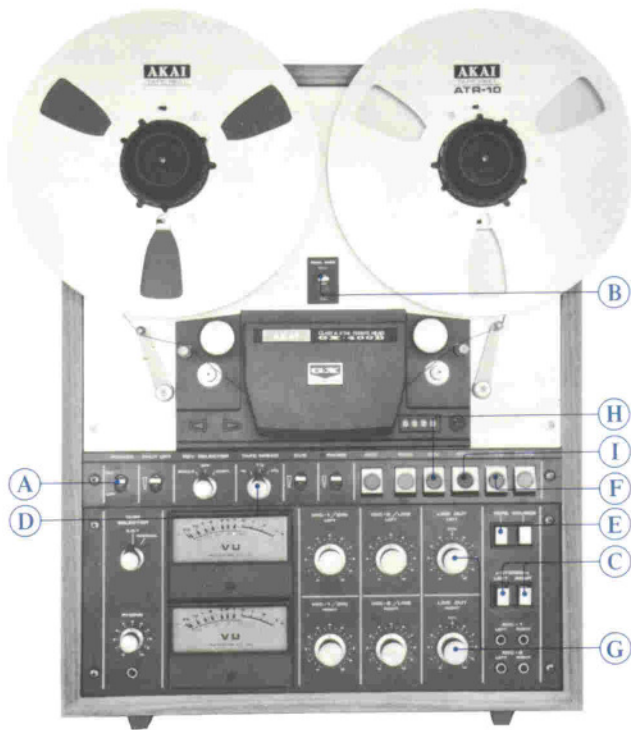

PLAYBACK

Make necessary connections as shown in CONNECTIONS FOR PLAYBACK, and read the operating precautions on page 4 before beginning operation. Then, load a pre-recorded tape following the instructions on page 4 .

Stereo Playback

1. Connect power cord and turn on Power Switch (A).
2. Set Reel Size Selector (B) according to reel size.
3. Depress both left and right Track Selector Switches (C).
4. Select tape speed with Tape Speed Selector Switch (D).
5. Depress TAPE Monitor Switch (E).
6. Depress Forward Button (F) to begin playback.
7. Adjust left and right Line Output Level Controls (G) and external amplifier controls.
8. Depress Reverse Button (H) for reverse playback.
9. Depress Stop Button (I) to stop playback.

Monaural Playback

Follow stereo playback procedure substituting the following steps for steps (3), (7) and (8).

Tracks 1-4

3. Depress left Track Selector Switch.
7. Adjust left Line Output Level Control and external amplifier controls.
8. Depress Reverse Button for playback of track 4.

Tracks 3-2

3. Depress right Track Selector Switch.
7. Adjust right Line Output Level Control and external amplifier controls.
8. Depress Reverse Button for playback of track 2.

CONNECTIONS FOR RECORDING



The Din Jack of the GX-400D can be used instead of the Line Input Jacks for connection with the external stereo amplifier. This enables recording or playback with a single connection cord. In this case set Din Jack Input Selector Switch to HIGH or LOW position to correspond with the output of the amplifier.

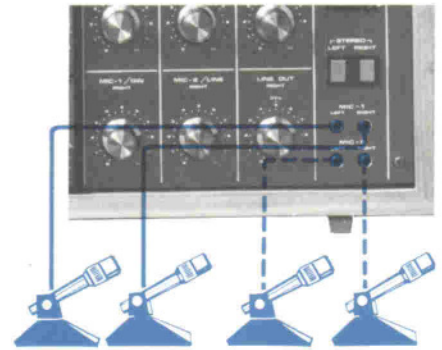

Use MIC-1 or MIC-2 or MIC-1 and MIC-2 together.

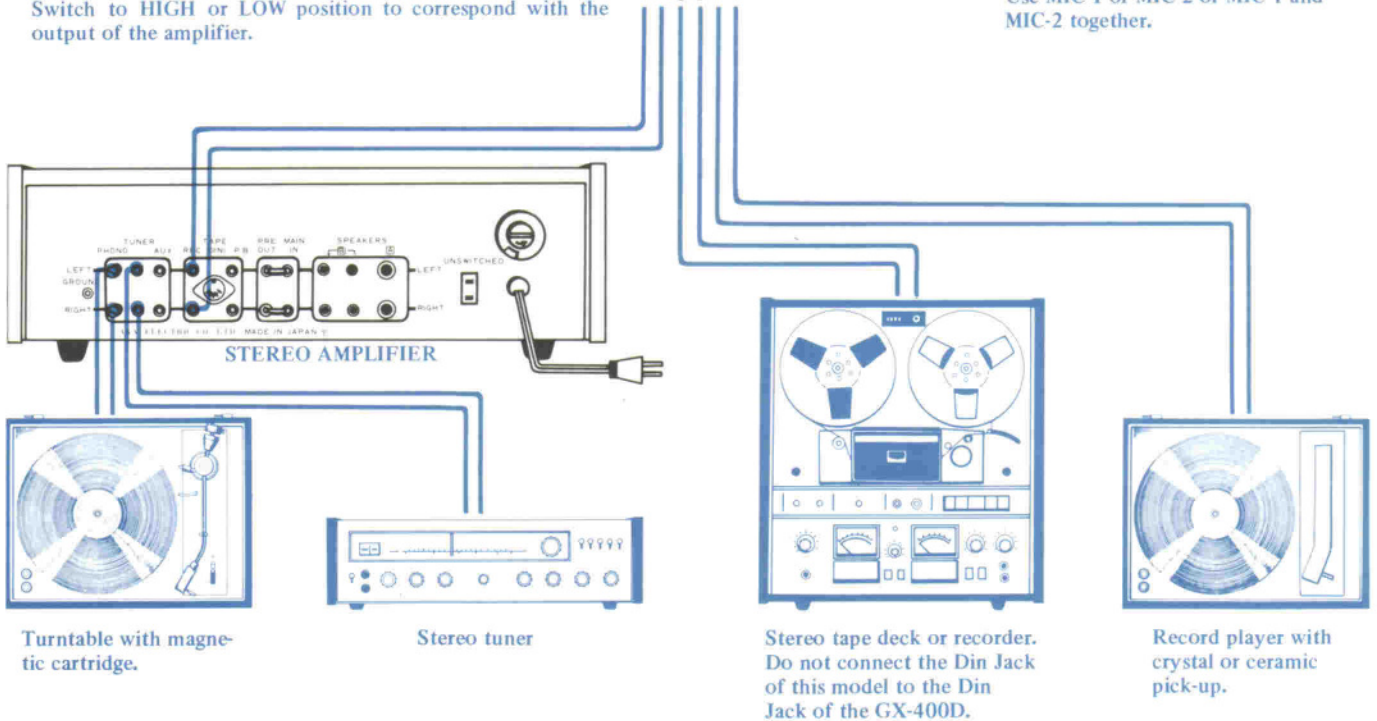

RCA/RCA plug connection cord



DIN/DIN plug connection cord



For monitoring use stereo headphones of 8 Ω impedance.

RECORDING

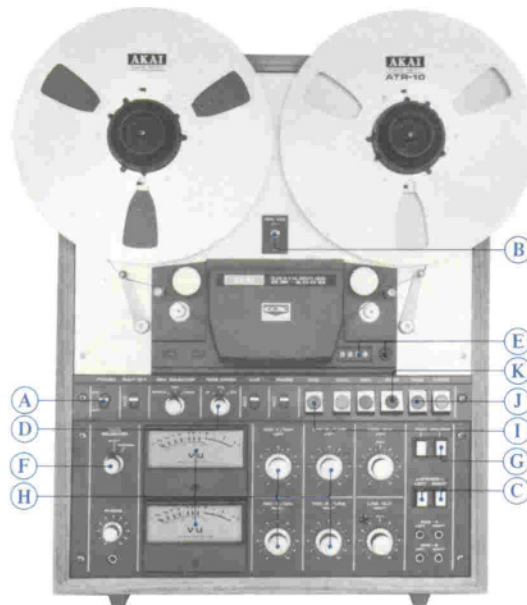

Make necessary program source connection to the appropriate inputs of this model as shown in CONNECTIONS FOR RECORDING, and read the operating precautions on page 4 before beginning operation. Then, load a tape following the instructions on page 4.

Stereo Recording

1. Connect power cord and turn on Power Switch (A).
2. Set Reel Size Selector (B) according to reel size.
3. Depress both left and right Track Selector Switches (C).
4. Select tape speed with Tape Speed Selector Switch (D).
5. Set Index Counter (E) to "0000." This provides an easy reference for locating positions on the tape.
6. Set Tape Selector Switch (F) to proper position. S.R.T position is for Akai Super Range Tape or other make low noise tapes, NORMAL position is for regular tapes.
7. Depress SOURCE Monitor Switch (G).
8. Adjust and balance input level with appropriate left and right Input Level Controls (H) while observing left and right VU Meters. Normal recording should not exceed zero VU level on either meter.
9. When an optimum recording level has been determined, while holding the Recording Safety Button (I) at depressed position, depress Forward Button (J) to begin recording.
10. Depress Stop Button (K) to stop recording. To momentarily stop tape movement use Pause Button.

* For normal recording, the S.O.S./Echo Selector Switch, at rear of unit must be set to NOR. position.

* For automatic reverse recording, please refer to page 5.

Monaural Recording

For monaural recording, follow stereo recording procedure, substituting the following steps for steps (3), (8), and add step (11).

Tracks 1-4

3. Depress left Track Selector Switch.
8. Adjust and balance input level with appropriate left Input Level Control while observing the left VU Meter. Normal recording should not exceed zero VU level.
11. For reverse recording on track 4, while holding Recording Safety Button at depressed position, depress Reverse Button.

Tracks 3-2

3. Depress right Track Selector Switch.
8. Adjust and balance input level with appropriate right Input Level Control while observing the right VU Meter. Normal recording should not exceed zero VU level.
11. For reverse recording on track 2, while holding Recording Safety Button at depressed position, depress Reverse Button.

ECHO EFFECT

For an interesting reverberation effect during recording, follow recording procedure and set the S.O.S./Echo Selector Switch at rear of unit to ECHO position after accomplishing step 9. Note that the MIC-2/LINE Input Level Controls must be set to maximum.

SOUND-ON-SOUND RECORDING

For transfer of previously recorded material from one track to another accumulating as many individual recordings on a single track as is desired. Use for language training or various interesting musical compilations.

First Recording

1. Connect power cord and turn on Power Switch.
2. Confirm that there are no connections to the input jacks and turn all input level controls to minimum.
3. Plug in microphone to left Mic-1 Microphone Jack.
4. Depress left Track Selector Switch for recording on track 1.
5. Depress SOURCE Monitor Switch.
6. Adjust left MIC-1/DIN Input Level Control while observing the left VU Meter.
7. With Reset Button, set Index Counter to "0000".
8. While holding Recording Safety Button at depressed position, depress Forward Button to begin first recording; i.e., Do-Re-Mi.
9. When the first recording is completed, rewind tape to starting point.

Second Recording

10. Confirm that the Monitor Switch is at SOURCE position and set S.O.S./Echo Selector Switch at rear of unit to S.O.S. position.
11. Depress right Track Selector Switch for recording on track 3 while monitoring track 1 through headphones. The left Track Selector Switch must be set to OUT position.
12. Set Line Output Level Controls to "0" VU (position 5) and plug in microphone to right Mic-1 Microphone Jack.
13. Set right MIC-1/DIN and MIC-2/LINE Input Level Controls to about position 7 or 8.
14. Connect stereo headphones for monitoring the first recording on track 1.
15. While holding Recording Safety Button at depressed position, depress Forward Button to begin recording; i.e., Do-Do'-Re-Re'-Mi-Mi'...

* The second recording (Do'-Re'-Mi' . . .) is made on track 3 as the first recording (Do-Re-Mi . . .) is heard through headphones. The two recordings will merge on track 3 (Do-Do'-Re-Re'-Mi-Mi' . . .).

* The third (Left MIC-2/LINE Input Level Control must be set to same level as right MIC-2/LINE Input Level Control) and subsequent recordings are made in the same way as the second by switching Track Selector Switches to and from 1-4, 3-2 and reinserting microphone to corresponding channel. For playback, set Track Selector Switch to track on which the last recording was made, depress the TAPE Monitor Switch, and set the S.O.S./Echo Selector Switch to NOR position.

SOUND MIXING

One of the features of this model is its varied sound mixing ability. MIC-1 + LINE, MIC-2 + DIN, LINE + DIN, or MIC-1 + MIC-2 can easily be accomplished. For sound mixing, choose any of the above combinations and follow recording procedure, connecting source to appropriate inputs, and adjusting input level controls accordingly in step 8.

TAPE ERASING

Any signals previously recorded on the tape will be automatically erased as a new recording is made. For erasing only, thread tape and set machine to recording mode. No plugs should be connected to the input jacks and the input level controls should be kept at minimum. For quick and complete erasure, a bulk tape eraser is recommended.

* Be sure that the proper Track Selector Switches are depressed. If both switches are depressed, both the left and right channels will be erased.

TAPE SPLICING AND EDITING

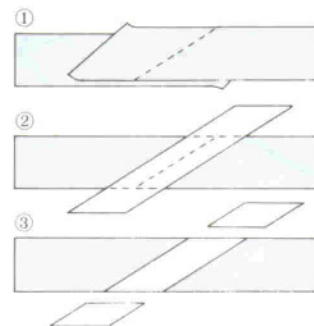
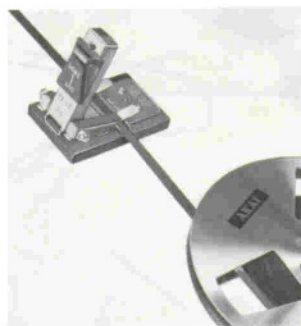

Cut the tape diagonally with an overlap so that the ends are lined up. Cutting tape on the diagonal eliminates detection of the splice in recording. Cover aligned ends with splicing tape, exerting pressure to secure ends evenly. Trim off excess splicing tape. Cutting into the tape very slightly will eliminate the possibility of a sticky splice. Splicing using scissors requires skillful work. For smooth and easy splicing, Akai Tape Splicer AS-3 is highly recommended.

MAINTENANCE

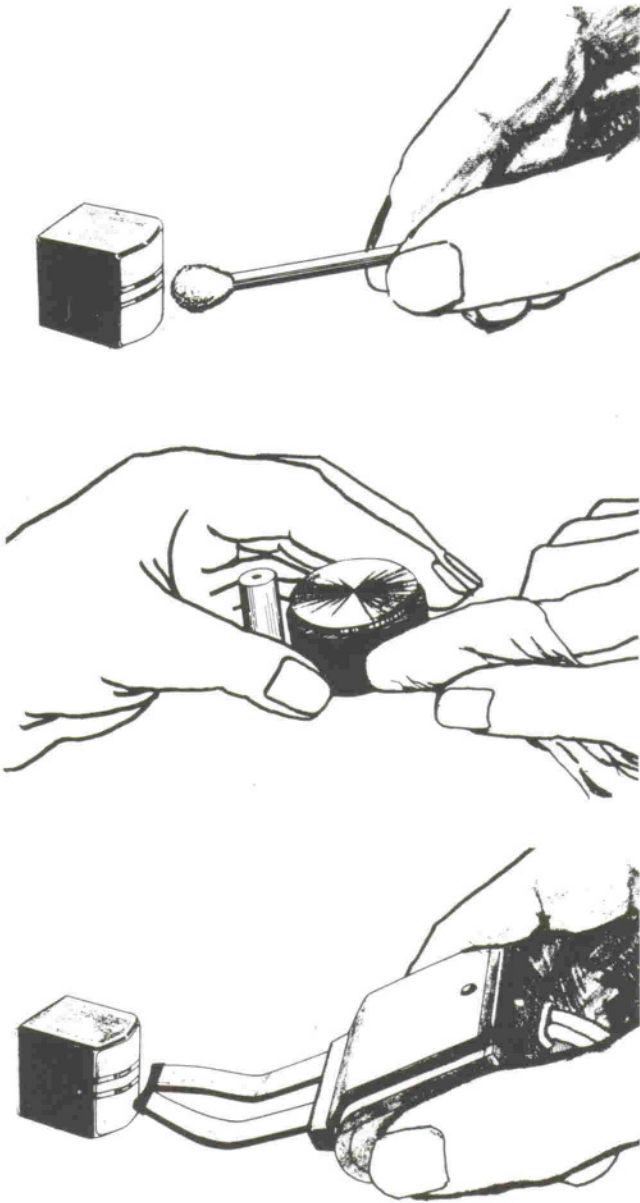

HEADS SHOULD ALWAYS BE KEPT CLEAN

The GX Heads do not normally require cleaning. However, if old tapes or tapes which have been spliced are used, head cleaning is recommended. Clean with a cotton swab stick which has been dipped in Akai Head Cleaning fluid from Head Cleaning Kit HC-500. If this fluid is not available, use alcohol.

PINCH WHEEL AND CAPSTAN CLEANING

If foreign matter is allowed to accumulate on the pinch wheels and capstans, these particles will come off on the tape causing deterioration of sound quality. Oil adhering to the capstans also causes irregularity in tape transport. It is, therefore, recommended that these parts be wiped clean periodically. For pinch wheel and capstan cleaning, use Akai Head Cleaning Kit HC-500, or, if this is not available, use alcohol.

* Do not use chemicals such as chloroethane, etc. as the rubber parts will deteriorate.

HEAD DEMAGNETIZING

Normally, the steel pole pieces which form part of the recording and playback heads become slightly magnetized. The effect of magnetization is that it causes considerable drop-out and introduces noise into the recordings. It is, therefore, recommended that head demagnetizing be performed periodically. This can be accomplished with a bulk head demagnetizer by bringing it close to the heads and making several circular motions over all head surface areas as well as the head housing.

* Be sure to cut off the power of the unit prior to demagnetizing the heads.

* Do not use magnetized tools in the vicinity of the heads or VU Meters.

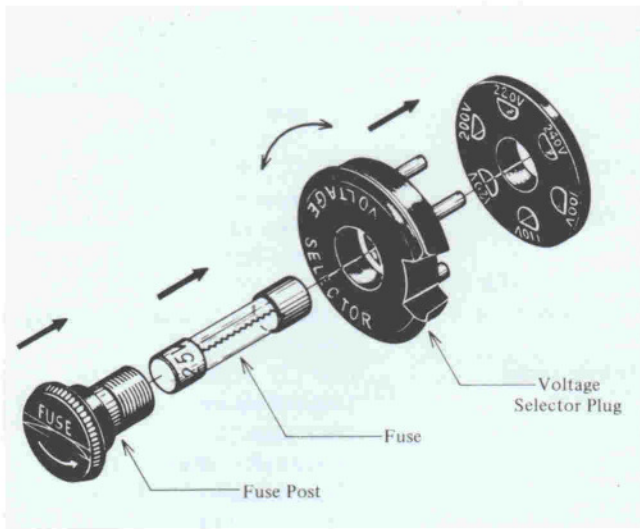

VOLTAGE & CYCLE CONVERSION

Voltage

This model is equipped with a built-in step-down transformer offering six stages of power voltage from 100 V to 240 V A.C. for world-wide operation. Voltage is preset at the factory according to destination. However, the operator is requested to check the setting prior to operation, and, if necessary, adjust as follows: (A) Disconnect power cord and remove Fuse Post by turning in direction of arrow. (B) Reset voltage selector plug so that proper area voltage shows through the plug cut-out. (C) Change fuse according to voltage: 100 V to 120 V: 2.5 A Fuse; 200 V to 240 V: 1.5 A Fuse. (D) Tighten fuse post.

* Be sure to disconnect power cord before attempting to readjust voltage.

* For optimum performance the line voltage must be held within a 10% deviation of standard area voltage.

Cycles

Correct tape speed cannot be obtained if the Cycle Conversion Switch on rear panel is not properly positioned. Set to 50 Hz or 60 Hz according to area power source.

TECHNICAL DATA

Track System	4 track 2 channel stereo/monaural system	Bias Frequency	110 kHz
Reel Capacity	Up to 10-1/2" reel	Heads	(4): 2-GX combination (Recording/Erase) heads 2-GX playback heads
Tape Speed	15, 7-1/2 and 3-3/4 ips ($\pm 0.5\%$)	Motors	(3): AC servo motor for capstan drive Two eddy current motors for reel drive
Wow & Flutter	Less than 0.035% RMS at 15 ips. Less than 0.05% RMS at 7-1/2 ips. Less than 0.08% RMS at 3-3/4 ips.	Fast Forward & Rewind Time	Within 90 secs. using a 1,200 ft. tape at 60/50 Hz
Equalization	Correct equalization for playback of tapes recorded to NAB curve.	Output Jacks	Line (2): 1.23 V ("0" VU)/100 Ω (Required load impedance: more than 10 k Ω) Phone (1): 50mV/8 Ω .
Frequency Response	20 Hz to 30,000 Hz (± 3 dB) at 15 ips. (Akai SRT Tape) 20 Hz to 28,000 Hz (± 3 dB) at 7-1/2 ips. (Akai SRT Tape) 30 Hz to 20,000 Hz (± 3 dB) at 3-3/4 ips. (Akai SRT Tape) 20 Hz to 28,000 Hz (± 3 dB) at 15 ips. 20 Hz to 26,000 Hz (± 3 dB) at 7-1/2 ips. 30 Hz to 19,000 Hz (± 3 dB) at 3-3/4 ips.	Input Jack	Microphone 4: 0.5 mV/4.7 k Ω Line (2): 100 mV/50 k Ω
Distortion	Less than 1% (1,000 Hz "0" VU)	Din Jack	0.6 V/20 mV (high)/5 mV (low)
Signal to Noise Ratio	Better than 54 dB (57 dB SRT Tape)	Semi-Conductors	Transistors: 93 Diodes: 87
Erase Ratio	Better than 70 dB	Power Requirements	100 V to 240 V A.C., 50/60 Hz
Cross-Talk	Better than 70 dB (monaural) Better than 45 dB (stereo)	Power Consumption	160 W max.
		Dimensions	457(W) x 590(H) x 240(D) mm (18 x 23.2 x 9.5")
		Weight	31.2 kg (68.7 lbs)

* For improvement purposes, specifications and design are subject to change without notice.

STANDARD ACCESSORIES

Empty Reel	(1)
Reel Adapter Hub	(2)
Connection Cord	(3-core areas: 1, others: 2)
Spare Fuses	(1 set)
Operator's Manual	(1)

TROUBLE SHOOTING CHART

The conditions listed below do not indicate mechanical failure of your unit. If your machine exhibits any of these conditions, check for trouble as indicated.

SYMPTOM	TROUBLE	REMEDY
Loss of sensitivity and tone quality.	<ul style="list-style-type: none"> * Dirty Erase Head. * Wrong side of tape facing the heads. * A.C. power lower than the voltage to which your machine is adjusted. * Magnetized head. * Tape Selector Switch is set incorrectly. 	<ul style="list-style-type: none"> * See HEADS SHOULD ALWAYS BE KEPT CLEAN. * See VOLTAGE & CYCLE CONVERSION. * See HEAD DEMAGNETIZING.
Machine will not record or playback.	<ul style="list-style-type: none"> * Check positions of controls and input/output. * Check position of the Recording Safety Button. * Check position of the Shut-Off/Tension Lever or Automatic Stop/Tension Lever * S.O.S./Echo Selector Switch at improper position. * Pause Switch at ON position. 	<ul style="list-style-type: none"> * Check and correct.
Irregularity in tape transport.	<ul style="list-style-type: none"> * Oil or magnetic particles adhering to the Capstan or Pinch Wheel. * Sticky or dirty tape surface. * Improperly loaded tape. * A.C. power lower than the voltage to which your machine is adjusted. * Sensing foil is affixed improperly. 	<ul style="list-style-type: none"> * See PINCH WHEEL & CAPSTAN CLEANING. * See HOW TO LOAD A MAGNETIC TAPE. * See VOLTAGE & CYCLE CONVERSION. * See AUTOMATIC & MANUAL REVERSE RECORDING AND PLAYBACK.
Tape will not run.	<ul style="list-style-type: none"> * Blown fuse. * Power is not being supplied. * Twisted or sticky tape. 	<ul style="list-style-type: none"> * Check power cord, Power Switch, and Shut-Off/Tension Lever or Automatic Stop/Tension Lever.
Previously recorded program will not erase.	<ul style="list-style-type: none"> * Erase head is dirty. 	<ul style="list-style-type: none"> * See HEAD SHOULD ALWAYS BE KEPT CLEAN.
Distorted or noisy sound.	<ul style="list-style-type: none"> * Recording level is too high. * Check external source controls and connections. 	<ul style="list-style-type: none"> * Normal recording level is zero VU.
No sound through headphones.	<ul style="list-style-type: none"> * Line Output Level Controls at minimum. 	<ul style="list-style-type: none"> * Set to "0" VU (5 position) and then adjust headphone: Volume Control.

MEMO

MEMO



MANUFACTURED & DISTRIBUTED BY
AKAI ELECTRIC CO., LTD.
AKAI TRADING CO., LTD.

12-14, 2-chome, Higashi-Kojiya,
Ohta-ku, Tokyo, Japan

AKAI AMERICA LTD.

2139 E. Del Amo Blvd., Compton, Calif., 90220, U.S.A.
TELEPHONE: (213) 537-3880
TELEX: 67-7494

Price US \$1.50



Printed in Japan

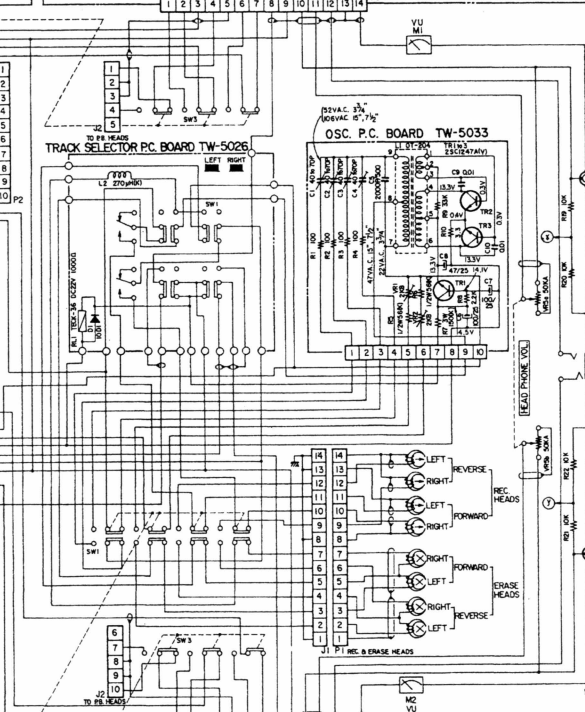
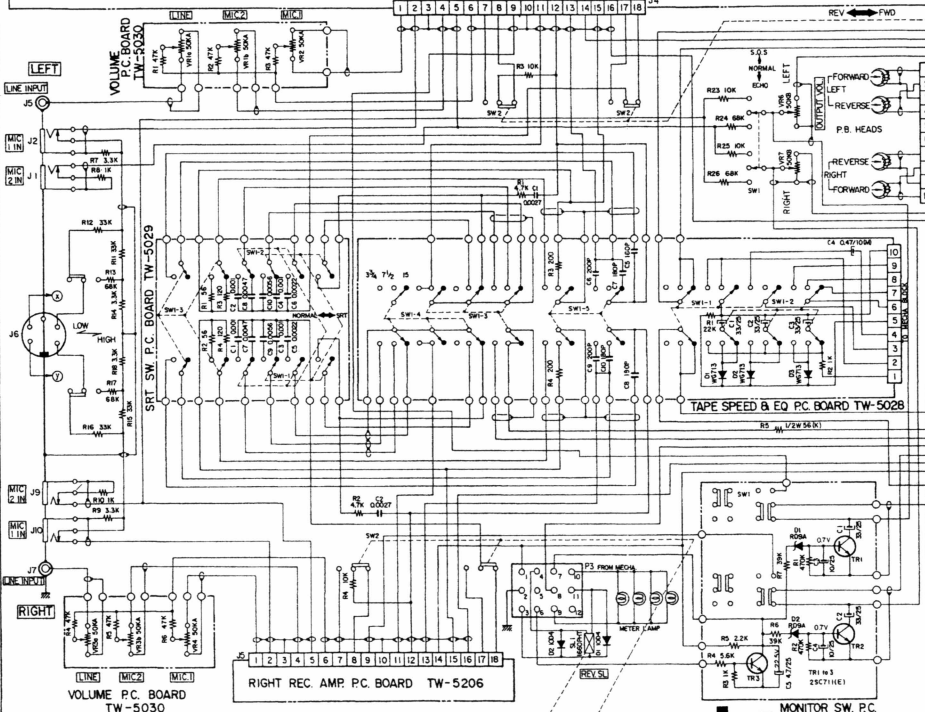
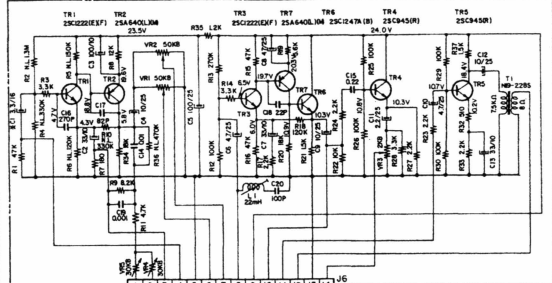
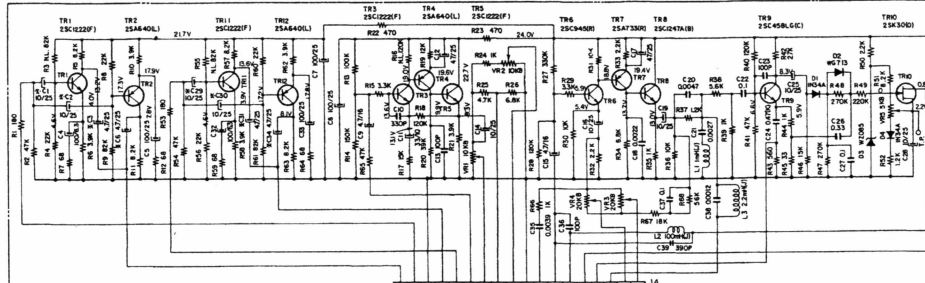

NOTE
 UNLESS OTHERWISE SPECIFIED
 ALL RESISTORS IN Ω (1/4W)
 ALL CAPACITORS IN μF (50V V.C.)
 K/L INDICATES KΩ/LEAKAGE RESISTORS
 S MARK INDICATES LOW LEAKAGE CAPACITORS

MONITOR SW. P.C. BOARD TW-5027
 REV ← FWD

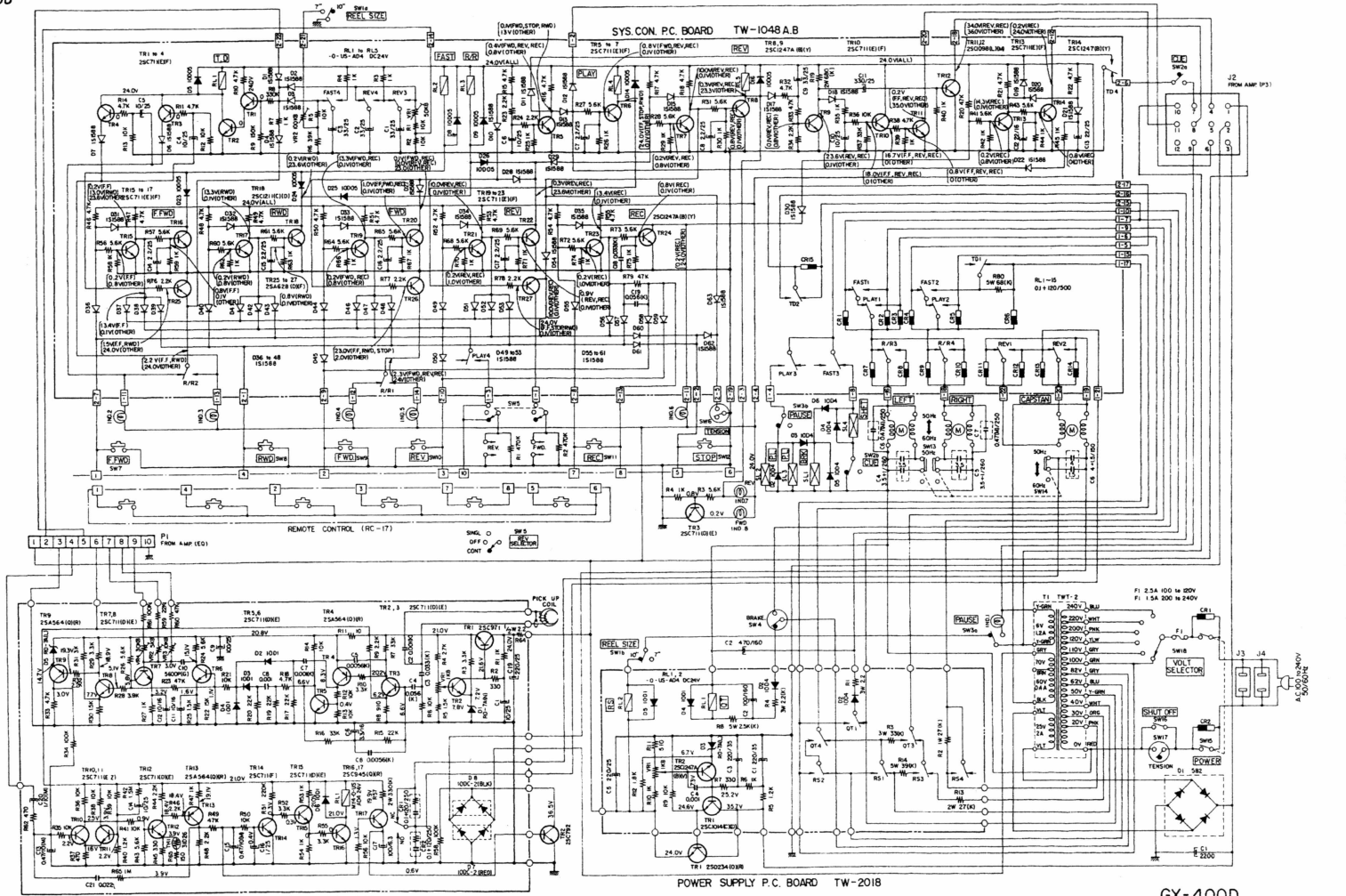

NOTE
 UNLESS OTHERWISE SPECIFIED
 ALL RESISTORS IN Ω 1/4W 5%
 ALL CAPACITORS IN μF 50V 5%
 ——— WAVE INDICATES SIGNAL GROUND OTHER 0-100/1000