

300 WATTS AND A CLOUD OF SMOKE

Basic Service Suggestions for the
CROWN DC-300 Amplifier

TABLE OF CONTENTS

	Page
List of Illustrations	i
Amplifiers Covered by Manual	ii
Part I: Frame of Mind	1
Part II: Familiarity	2
Part III: Equipment	3
Part IV: Blood, Sweat, and the Smell of Burnt Parts	7
A. Illustrations Explained	7
B. General Service Procedure	8
C. Checkout and Repair	8
1. Establishing Problems	10
2. Finding and Eliminating Problem Sources	11
3. Mechanical Problems	34
Part V: Parting Shots	36
Appendix A: Pictures and Diagrams	
Appendix B: Parts List	
Appendix C: Change List	
Appendix D: DC-300 Operation Theory	

LIST OF ILLUSTRATIONS

In Text

	Opposite Page
1. Bias Voltage: Time Behaviour	16
2. Protection Waveform	28
3. 20 KHZ Test Results	29
4. 10 KHZ Square Wave Test Results	30
5. IM Distortion Test Set-Up	30
6. Noise Test Set-Up	32

Appendix A

Photographs:	A-1. Outside Front View
	A-2. Outside Back View
	A-3. Outside End View
	A-4. Chassis: Inside--Without Heat Sinks
	A-5. Heat Sinks: Unmounted
	A-6. Chassis: Inside--With Heat Sinks
	A-7. Fuse Chassis: Inside
Diagrams:	A-8. Main Board Layout
	A-9. 120 Volt Supply Board Layout
	A-10. Schematic Diagram
	A-11. Typical Test Set-Up
	A-12. Typical Checkout Results

This Manual is being published after completion of amplifier number A2048. Changes in units with higher numbers may not be included in the manual.

PART I: FRAME OF MIND

Some people become afraid when a \$700 amplifier refuses to work properly. Other people become angry. Neither of these attitudes solves the problem with the amplifier. People who are afraid hesitate to look very far for the problem; people who are angry are likely to increase the damage by ignoring standards of reasonable care in their repair efforts, and in extreme cases will even throw things around. (This last problem occurs infrequently with DC-300's: they are too heavy to be thrown very often or very far.)

Both fear and anger in this case result from too little knowledge. Anything that is not understood is to be feared or beaten. Ordinarily this lack of knowledge only causes mild cases of agitation and inconvenience, but a large amount of money invested (\$700) can magnify slight cases of upset into rampaging attacks. Enough information in an available form will go miles and miles towards a peaceable and effective service operation. No one knows how far this manual will go in that direction.

It seems reasonable to believe that a large and expensive amplifier should have huge, mind-boggling troubles, not to be compared with those encountered by, say, a six-transistor radio, or an electric toothbrush. Therefore, when DC-300 amplifiers have problems, those problems must range from very bad to terrible. Intuition fails because most DC-300 troubles can be traced and eliminated with a very reasonable supply of knowledge and time. (The equipment needed to do this properly is a different bag of pretzels; more will be said about this later on.)

So relax. Do not be afraid. Do not be angry. And try to avoid going to sleep while reading the rest of this manual.

PART II: FAMILIARITY

Almost anyone who looks often enough at the insides of DC-300's will begin to feel reasonably confident servicing them. Familiarity, sooner or later, should breed confidence. This manual, sooner or later, should breed familiarity. Ideally it will produce a working acquaintance with both the electronic operation and the physical layout of the DC-300. Probably the single most helpful accomplishment in this process is the ability to match the schematic diagram with the actual circuit components. The amplifier is complicated enough to be puzzling until this is done, but once this familiarity is established, it becomes much easier to translate suspected problems into checkout procedures. The instruction manual for the amplifier is worth reading thoroughly. Knowing how and why the DC-300 is supposed to operate, and the kind of treatment it wants, will contribute measurably to understanding the problems which it may encounter.

PART III: EQUIPMENT

It has been hinted above that the equipment needs for servicing DC-300's are considerable. It was a pretty good hint, as the listings below will demonstrate. Depending upon how much equipment the service shop already has available, the process of obtaining the rest lies someplace between a major and minor hassle. Some of the test gear which is difficult or impossible to obtain commercially will be sold in limited supply by CROWN.

There is a loophole in these equipment needs, however. A good percentage of problems in the past have fallen into a single area, and can be handled with a smaller supply of equipment. But (herein lies the rub) factory specs cannot be guaranteed after repair without a checkout involving the full range of equipment specified below. (This is the major reason why most service work has been done at the factory until this point.) Most of the actual troubleshooting, as will become clear later on, can be done with an oscilloscope, an ohmmeter, a voltmeter, and a signal generator. Generally the best service procedure requires going as far as possible (depending on the equipment available) along the steps described in the section on service techniques. Any problems which cannot be solved should then be referred to the factory.

EQUIPMENT LIST

Equipment	Requirements	Uses	Suggested Model & Price
Oscilloscope	Capable of displaying a 10 megahertz signal	Monitoring output during service and testing of amplifier	Telequipment SS4A (\$450)
VOM	Low-voltage resistance probe (100mv range) Higher voltage resistance probe (1.5 volt range)	Check resistance values (low-voltage probe) check semiconductor junctions for opens or shorts (higher-voltage probe) Check DC operating voltages of amplifier	Triplet 601 (includes both voltages needed) (\$160)
Signal Generator	Sine/square wave available. Flat frequency response	Provide test signals for service and checkout (including 10KHZ sq. and 20KHZ sine)	Wavetek 130 series (\$300)
Wattmeter	Read with reasonable accuracy at 20W without cutting into voltage at high power levels.	Check power consumption of amp	Simpson 390 (panel meter-1379)
Power supply	460volts available; current limits to 125ma; meters reasonably accurate at 50ma	Preliminary check-out of fuse-blowing amplifiers-- to prevent destruction of more parts	Lambda LPD 423 FN (\$325)
Circuit Breaker	15amp rating	In the AC line to the DC-300--protect other circuitry from overload if power supply has shorted	
AC Line Monitor	Peak reading meter	Monitor line voltage for amplifier testing.	Available from CROWN

Equipment	Requirements	Uses	Suggested Model & Price
Variac		Keep line voltage at 120v during tests.	Superior Powerstat 116B (\$43) or equivalent
AC Volt-meter	100mv low range	Set output level for testing check noise levels	Hewlett-Packard 400F (\$300)
Filter	20-20KHZ band-pass low-noise	Between amp and voltmeter in noise test	Available from CROWN
Inter-Modulation Distortion Analyzer		Check inter-modulation distortion from 150w-15mw	Available from CROWN (\$595)
Dummy Load	2-4-80m; able to dissipate 500 watts without strain; less than 10% reactive component at any frequency up to five times the highest test frequency (5 x 100KHZ=500KHZ)	Check amplifier performance under load	Available from CROWN

Additional Useful Equipment

AC-DC Calibrator: The meters recommended should stay in calibration with only periodic checks (every 6 months). But if this quality equipment is unavailable, and lower quality test instruments are used, the instruments should be checked frequently (whenever significant measurements have to be made) for calibration. Unfortunately, there is no cheap or easy way to do this. A good AC-DC Calibrator is expensive. The Hewlett-Packard 6920B, for instance, costs a cool 700 clams. The desired result, then, can be obtained either by purchasing expensive equipment that can be calibrated and trusted to stay in calibration over a period of time, or by purchasing an expensive calibrator to make possible the frequent calibration

necessary on less dependable equipment. The overall point is that is is important to know the accuracy and dependability of test measurements, so that the performance of the amplifier can be accurately evaluated.

Curve Tracer/Transistor Checker: Sometimes it becomes important in servicing electronic equipment to evaluate individual semiconductor performance. This may help determine reasons for particular kinds of failure, and may as well be helpful in selecting replacement components for damaged parts. Ideally, a curve tracer such as the Tektronics 576 should be obtained, but the cost of this instrument is \$2250. If something like a Tektronics 561 scope is available, a plug-in unit can perform this function--at a modest cost of 500 bills. All of this, while potentially valuable (obviously for more than just CROWN servicing), is also clearly expensive. A less expensive route would be an investment in a transistor checker. This kind of equipment can provide much useful information and save much useful money. Heathkit produces one of the best of these for around \$60. SECO, Sencore and B & K also produce models. The use of this equipment represents a refinement of service technique that may or may not be worthwhile, depending on the amount and kinds of service performed by the individual shop.

PART IV: BLOOD SWEAT AND THE
SMELL OF BURNT PARTS

A. Illustrations Explained

A collection of illustrations, diagrams, and lists at the end of this manual serves first to locate and identify individual parts. The circuit layouts and chassis pictures (fig. 1-9) show the positions of the components along with their identifying numbers.

The schematic diagram (fig. 10) describes the circuit electronically, and shows the identifying numbers corresponding to those on the circuit layouts and pictures. Also included on the schematic are the normal quiescent DC voltages for the circuit, which can be used as a checkout standard for defective amplifiers. Significant changes in the circuit board have also been included, along with some wire color coding and indications of signal and feedback paths.

The diagram of the test set-up (fig. 11) shows the general array of equipment needed for complete service and checkout, with the connections between the pieces of equipment. Variations in the selection of equipment have been discussed above. A checkout sheet showing typical results of a factory test is also included.

The parts list (appen. B) makes the process of obtaining replacement parts fairly easy. Indexed according to the identifying numbers on the schematic and layout illustrations, the list gives CROWN part numbers for easy replacement of parts.

The final list includes the various major changes (appen C) that have been made in fabrication and parts since the introduction of the amplifier. It should explain why all parts are not necessarily identical in different units. The changes are listed by component numbers, and show the amplifier serial numbers involved. Changes besides these may be attributed to: (1) Factory errors which do not happen very often according to our service records, and which we wish didn't happen at all; (2) Customer modification and repair efforts

involving unusual imagination as well as unusual components; (3) Gremlins (not to be confused with the kind you drive; these gremlins are impossible to describe and are absolutely unpredictable.)

Besides the illustrations mentioned above, various others have been included with the related material in the text.

B. General Service Procedure

Fundamentally we are looking for an abnormal situation. When a problem has been observed, it is obvious that something is not doing what it is expected to do. One part or several parts may be doing the bad work, by shorting, opening up, burning up, leaking, exploding, or just finking out, but the point is that something is happening abnormally and we want to source of the abnormality. The most efficient general method of finding the source involves a comparison between the normal operating parameters (such as voltages) of the amplifier and the abnormal measurements of the defective amplifier. This reemphasizes the need for familiarity with the amplifier and its normal operation.

This sounds on the surface like a reasonably easy way to find problem sources. Under the surface it may turn into a can of worms. The trouble is that in most situations one bad part will cause abnormal performance by other components. A shorted transistor will wreck the balance of the whole amplifier; an oscillation coming from a bad transistor junction will propagate through the entire circuit. So we have to distinguish between parts that are actually causing problems, and parts that are only responding to abnormal conditions. This can become fairly involved; the manual hopes to keep the involvement orderly.

Patience is worth seven dollars a minute.

C. Checkout and Repair

The service process divides into three areas within the time a defective unit spends on the service bench:

(1) The problem must be identified or discovered--this may be obvious,

or may be complicated by a lack of information about the defect.

(2) The source of the problem must be discovered--this can be anywhere from very easy to very frustrating.

(3) Repair work must be done to eliminate the problem--usually this is obvious when step 2 is completed.

The following notes are likely to be useful at any point from here on in the service procedures:

NOTE ON DISASSEMBLY AND REASSEMBLY

Taking the DC-300 apart is not hard at all--but one recommendation is in order; the front panel should be completely removed from the unit and put in a safe spot until it is replaced on the unit. Any kind of tool steel or other hard metal can scratch the face of the aluminum panel and it is best to handle it carefully.

The extrusion fitting over the lower edge of the front panel comes off first, by removing three screws on the bottom front of the unit. Before the panel is removed it makes sense to unplug the amp to avoid accidents. The level controls should be disengaged from the panel. The knobs can be loosened with a hex driver or an allen wrench and the pot loosened with a nut-driver. It is possible to work with the pots still mounted on the loosened panel, in which case the panel is connected to the chassis only by the input level cables. But this procedure can result in broken input wiring and panel scratches, and it makes the unit generally inconvenient to move. With the level pots loosened (do not allow them to drop inside the amplifier) the panel can be removed by taking out the four mounting screws. The cap on the on-off switch should just lift off when the panel is removed.

The means of removing the circuit boards and fuse panel are obvious. Two sheet metal screws mount each main board to its heat sink, and two screws mount the fuse panel to the bottom of the chassis. Whenever the circuit boards are loosened and the unit is to be powered, use some sort of insulation (like a folded cloth) under the board to be sure it cannot be shorted to the chassis.

In reassembly, be careful to line up the tabs on the level control pots as well as possible with the small holes in the panel. Continue to be careful with the panel. (The screwdriver used to mount the panel will probably try to jump out of its slot and skip across the panel-- watch for this.) Make sure the lens cap on the indicator light fits over the indicator bulb and does not crush the bulb or bend it out of the way.

NOTE ON VISUAL INSPECTION

Detailed visual inspection is worth doing for almost all problems. Wires soldered well enough to pass the original factory checkout may later work loose and cause difficulties. Suspicious wires should be pulled gently to make sure they are securely fastened. Transistor leads in particular and all component leads in general can suffer the same problem of loosening, causing oscillation, noises and DC imbalance. A visual check may also reveal parts which have been badly damaged by heat or high power and at least part of the service problem will become immediately apparent. It is probably understood already that any wire or lead which chooses to come loose will do so in the darkest and most inaccessible corner of the amplifier.

(Murphy's Law)

1. Establishing Problems

The complaints accompanying defective amplifiers may be less than crystal clear and classic in their simplicity. They may in fact be ambiguous and misleading. Furthermore, it is not necessarily true that every amplifier returned for service actually has something wrong with it. Problems which arise from the systems in which the amplifiers are used may be blamed on the amplifiers. First we want to know exactly what, if anything, the amplifier is doing wrong (this is known as the CROWN Principle "Commence Repair Only When Necessary")

It is usually much better to get the complaint(s) from the customer's own personal mouth than it is to try comprehending his written complaints. A first hand account of the problem can help in: (1) getting the problem to recur on the service bench, and (2) getting

an idea of the probable causes of the difficulty. Some problems are too much to miss--like blown fuses, shattered parts, and the lingering aroma of burnt components, but in case the problem is not so easy to find, it may be helpful to know:

- 1) Exactly what was the problem? How was it noticeable? Which channel(s) caused the trouble?
- 2) What are the details of the system in which the amplifier was operating? Has the system been carefully checked for possible problems outside the amplifier?
- 3) What kind of signal and load were involved? (This may indicate a component failure under high voltages or current)
- 4) How long had the amplifier been in operation when the failure occurred. Was it warmer than usual?
- 5) Did the problem occur once, or repeatedly? If it happened more than once, were the circumstances the same for all occurrences?

Depending on the type of problem, these questions may or may not prove useful; they are designed to get as much information about the occurrence of the problem as possible.

If the customer turns out to be unavailable or unhelpful and the problem is not obvious:

- 1) Begin the regular checkout as detailed below.
- 2) If the unit passes all the tests with no problems, open up the unit and go through the visual inspection.
- 3) If the visual inspection turns up no problems, apply a signal to the amplifier and begin checking the circuit board components by tapping on them gently, and by heating and cooling them. Transistors and diodes are most likely to cause problems under this test if they have been causing problems before. Precision resistors may also show up as bad. If none of this seems to affect the output significantly, the last hope is to use the amplifier normally for awhile and see if the customer's problem shows up.

2. Finding and Eliminating Problem Sources

This section is organized on the basis of the factory checkout procedure. The common service problems appear under the parts of the

checkout procedure where they are likely to show up. An attempt has been made to keep the details to a minimum and to cover the major service problems adequately. (Murphy's Law plainly says that no such service manual exists--so that may have been far too much to dream about.)

The notes that are casually strewn about the manual are not as random as they seem. At least they are not supposed to be. The purpose has been to add them at the points where they would most likely find application. And now here are two notes to begin the parade:

NOTE ON LOADING: The amplifier should not ordinarily be operated with a load until it is performing properly unloaded. If there is something seriously wrong with the amplifier, the load will only compound problems by blowing fuses and perhaps damaging components by drawing high current. (The current limit suggested for the limited supply will not allow it to drive an eight ohm load.)

NOTE ON OHMMETER TESTS: The equipment list specifies that two different test voltages should be available on the ohmmeter (or two different ohmmeters). Checking semiconductors can be done with the usual 1.5 volt probe. On the R X 1 scale, the normal forward breakdown resistance for semiconductor junctions will usually fall in the 5-15 ohms range.

In cases where it is desirable to check components without forward biasing any junctions (such as the checking resistor values without removing them from the circuit), the low voltage probe should be used (this will be in the range of 100mv.)

In any case, the effect of parallel resistance paths has to be considered in deciding whether or not a test reading is what should be expected. The simplest procedure for establishing the proper value for any reading is a comparison with the same reading under the same conditions on a properly functioning channel. If only one channel in an amplifier is causing trouble, use the other channel for comparison when taking resistance readings. In case both channels are bad, compare the readings with those on the good amplifier.

This comparison technique will become less and less necessary as more units are serviced and the normal resistance values become familiar. Some of the usual values are included in the following service information, but in order to avoid the barrage of numbers necessary to cover all possible measurements, the comparison method had been suggested.

The approximate values for transistor resistance measurements appear below. Large resistance means there will be little or no indication on the R X 1 ohms scale. These values apply to a transistor by itself outside the circuit. The base-emitter and base-collector readings in a given transistor should match within an ohm or two. In an actual test the first lead in the listing below takes the positive meter probe for an NPN transistor. For a PNP the first lead of each pair takes the negative probe.

Base-emitter	5-15 ohms
Emitter-base	Large
Base-collector	5-15 ohms
Collector-base	Large
Collector-emitter	Large
Emitter-collector	Large

Diodes should show about 5-15 ohms forward resistance and large reverse resistance.

It is important as well to be familiar with the ohmmeter(s) being used. All models do not operate with the same conventions. For example, some make the positive lead common, others the negative. It is obviously important to be aware of this when trying to decide whether the forward or reverse resistance of a junction is being read. Some meters also use a nine volt test voltage on high resistance scales. This voltage can forward bias enough junctions in a solid state circuit to cause avalanche confusion. So be sure the test voltage is known for the scale used.

CHECKOUT PROCEDURE #1: TURN-ON

NOTE ON LINE VOLTAGE: Use the proper line voltage, which is the one for which the transformer primary of the amplifier is connected. The voltage should be measured throughout the testing with a peak reading meter and adjusted to the RMS equivalent voltage (to compensate for

line voltage regulation errors during the course of the measurement). All measurements should be taken at the power amplifier's plug. When testing the IHF music-power measurements, the line voltage is to be set at 120V when the amplifier is connected to 117V, (IHF standards). If the amp is connected otherwise, the equivalent test may be given by applying 128 volts on 125V, 240V on 234V, or 256V on 250V.

NOTE ON TEST EQUIPMENT GROUNDING: Whenever possible avoid ground loops in the test equipment caused by connecting the output ground to the input ground. Never connect the ground of the cable going to the load back to the input ground.

Ground loops are especially obnoxious when measuring distortion. An IM analyzer, for example, has its input and output terminals tied to common ground. Such a test should use an ungrounded output return, with the output lead wrapped around the well-shielded and grounded input cable.

Plug in the amplifier (no load and no signal). Turn it on. The line fuse (center of fuse rack) and the indicator light should stay whole and light up respectively. If these things do not happen, we are already losing.

CHECKOUT PROCEDURE #1: TURN-ON

Symptom	Possible Causes	Service Procedure
AC fuse blown	wrong size fuse, wrong line voltage, etc. pinched wires in power supply short in power cord or transformer primary miswiring of transformer primary	Try another fuse, to make sure the first did not blow due to problems outside the amplifier. Go through a visual check of the power supply wiring (see power supply schematic at bottom of overall schematic <u>fig. 10</u> ; Also picture <u>fig. 7</u>) Use ohmmeter to check power cord for hot-to-ground short (with switch "on" contacts of plug should show about .35 ohm resistance. This is the transformer primary resistance. It should <u>not</u> be Zero) Check transformer primary wiring according to the color code on the schematic.

Symptom	Possible Causes	Service Procedure
AC fuse blown	Short in rectifier	Use ohmmeter to check forward and reverse resistances of rectifier diodes CR1, CR2, CR3, CR4. <u>NOTE:</u> Through unit numbers A1788 the rectifier was composed of 4 power diodes press-fitted into aluminum bars, which were in turn epoxied to a plate on the top panel of the amp. The arrangement has been replaced by a one piece rectifier bridge, mounted by a single screw and using slide-on contacts. If a rectifier diode has failed in either case, the handiest replacement is one of the new one-piece rectifiers (order from parts list along with 4 clips for the leads)
	short in capacitors C2 or C3 (very rare event)	Use ohmmeter to check resistance across capacitor terminals; since the rectifier diodes run across these terminals, the resulting measurements should be large in one direction and low in the other.
AC power okay but indicator light does not come on	bulb leads unsoldered or R6 unsoldered	Check 120 Volt supply board (fig.A-9) for unsoldered bulb or resistor (R6) leads.
	Bulb Defective	Replace
Fuse okay but no power	switch failure	Use ohmmeter to check making and breaking of switch contacts.
	Defective thermal switch	Check thermal switches with an ohmmeter; normally they should show no resistance across the contacts (they should only open when heated).

CHECKOUT PROCEDURE #2: 1 KHZ SIGNAL - NO LOAD

The AC power should be okay according to the fuse and indicator light. Connect a signal generator set at 1 KHZ to the input. Begin monitoring the output with an oscilloscope. Turn up each level control and observe the output.

Biasing: This should be checked at this point or as soon as possible. An offset voltage or oscillation may change the level--so bias should be checked after these problems have been solved, if they exist. But if

there are no major problems at this point (they should be visible on the scope if they are around), the biasing should be done immediately.

The front panel must be removed for the check. With the amplifier turned on but no signal applied, measure the voltage across R123, the 5.6 ohm resistor mounted on the corner of the circuit board beside the positive pre-driver. The voltage should be $0.325v \pm 0.015v$. The measurement should be made before the amplifier has warmed up - immediately at turn-on, if possible. The graph below demonstrates the behavior of this voltage with time, in an amplifier carrying no signal. The voltage begins to climb at turn-on, and, after peaking gradually drops back to the desired level. Unless the measurement is made at turn-on, or after the amplifier is thoroughly warmed up, it is likely to be misleading.

It should also be pointed out that after an amplifier has been warmed up and then turned off, the bias appear low if it is turned on again within 10 minutes. After an amp has been turned off, either leave it off until it cools thoroughly, or else allow it to warm up thoroughly again before measuring the bias.

The bias level will not ordinarily need any adjustment unless components which affect the level (such as the bias diodes or Q1, Q11, or Q114) have to be replaced. When a change is necessary, it is accomplished by selecting the value of R126 in the string of bias diodes (CR105-CR108). Raising the value of R126 increases the base voltage on the pre-driver stage of the amplifier, which turns the pre-driver on harder and increases the current through R132 (and R138 on the negative side). In the reverse of this process lowering the value of R126 will lower the bias on the pre-driver and driver stages. Below is a short table which gives an idea of the relationship between the size of R126 and the bias level. For the sake of the illustration we are assuming that R126 = 75 ohms. All possible values are not included on the chart (in particular, larger resistances than 120 ohms are sometimes needed).

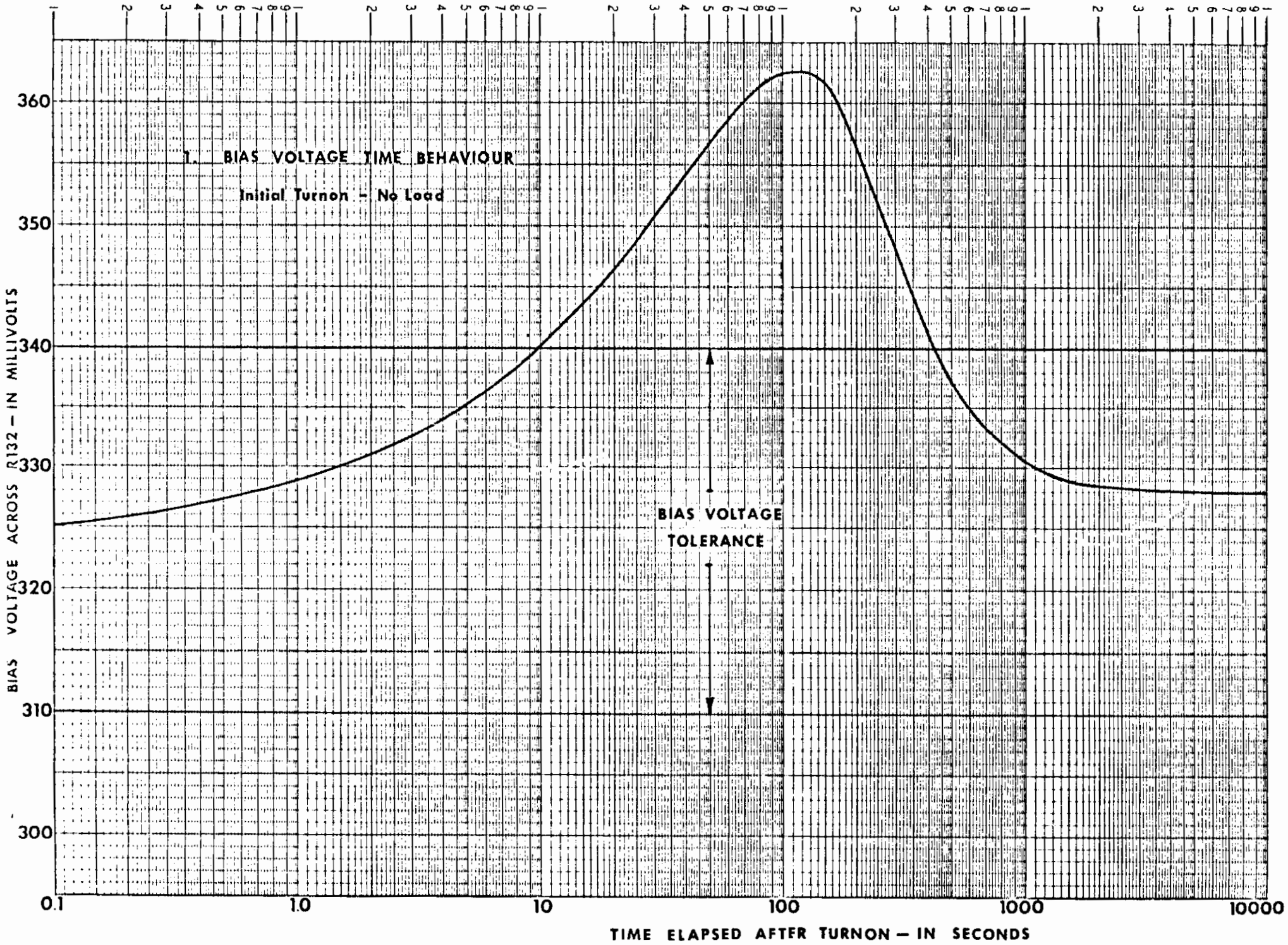

1. BIAS VOLTAGE TIME BEHAVIOUR

Initial Turnon - No Load

BIAS VOLTAGE TOLERANCE

BIAS VOLTAGE ACROSS R132 - IN MILLIVOLTS

TIME ELAPSED AFTER TURNON - IN SECONDS

<u>Voltage error from 325mv</u>	<u>Resistor size in ohms</u>
+60 mv	51 ohms
+45	56
+25	62
+10	68
0	75
-10	82
-25	91
-35	100
-45	120

If no output signal appears when the level control is turned up, check the DC fuses and continue in the procedure described below:

<u>Symptom</u>	<u>Possible Causes</u>	<u>Service Procedure</u>
Fuses initially blown	Thousands of things	replace blown fuses and try again.
Fuses blow again (no load)	Output transistors shorted (Q2, Q3, Q5 Q6) NOTE: This problem has occurred more frequently with some types of output transistors than with others. In recent batches the problem has been lessened by a more rigorous testing of the transistors before they are used. As time goes on, this problem should occur with decreasing frequency. NOTE: In this case and in those following, something must short in both positive and negative output circuitry to blow the fuses with no load. If only one output, driver, or diode shorts with no load, the opposite polarity	<u>WARNING:</u> Do not insert and blow DC fuses repeatedly. Once is enough to demonstrate that there is a real live problem. When fuses blow, momentary voltage surges may reverse-bias electrolytic capacitors C106, C112, and C6 and eventually destroy them. Units with shorted output transistors may have some of these capacitors already destroyed by repeated attempts to get the amp going again with more fuses. <u>EXTERNAL SUPPLY:</u> It is at this point that the external supply should be used. Set the current limits to 125ma and the voltages to +60 volts. Ground the supply to the amplifier (the output ground post is a convenient part) clip the +60 lead to one of the mounting screws of the positive driver transistor (Q1) and clip the negative lead to the top terminal on the terminal strip (the one with the blue negative supply lead soldered to it.) The purpose of the external supply is to avoid blowing fuses and perhaps damaging parts (if a component shorts and threatens to carry enough current to burn up something else.) If an external supply is not available, check the output circuitry carefully for

Symptom	Possible Causes	Service Procedure
Fuses blow again (no load)	<p>components will turn off, blocking excess current and leaving the amp with a plus or minus 60 volts at the output. If a load is connected which shows a low DC resistance, the current from the 60 volts DC will kill the fuses. In operation, the surge occurring when one output transistor shorts under load may kill the weaker of the two output transistors of opposite polarity. For this reason, a damaged channel will often show one positive and one negative output shorted.</p> <p>Output transistors shorted (Q2, Q3, Q5, Q6).</p>	<p>shorts (as described below) with an ohmmeter, after doing repair work, to avoid doing more damage. It would also be worthwhile to substitute 1/2 amp fuses for the checkout (without load) just after extensive repair work. This will cut down the current surge in the event that something is still shorted.</p> <p>Turn off the amp and use an ohmmeter to measure the resistance from the +60 volt supplies to the output of the amplifier (Measure from the contacts of power resistor R4 to the driver transistor mounting screws <u>fig. A-5</u>). Using the low voltage resistance probes on the R X 1 scale, the normal resistance should be too large to cause any indication on the meter.</p> <p>WARNING: The circuit may still have some charged capacitors which will cause an initial indication on the ohmmeter. These should discharge fairly quickly and allow the meter to indicate a very large value, if nothing is damaged.)</p> <p>Shorted transistors (or a shorted flyback diode) will give a very low reading--from a few tenths of an ohm to a few ohms.</p> <p>To determine whether transistors or diodes are at fault clip one lead of the ohmmeter to the driver mounting screw of the supply being tested; apply the other lead to the output transistor emitter leads in turn. If both readings are the same, then</p>

Symptom	Possible Causes	Service Procedure																														
Fuses blow again (no Load)	Output transistors shorted (Q2, Q3, Q5, Q6)	<p>the flyback diode is shorted. If the readings differ by 0.4 ohms, then the output transistor showing the lower resistance reading is the shorted one (the 0.4 ohm difference comes from the sensing resistors R4a+b or R4d+e).</p> <p><u>Replacing output transistors:</u> If output transistors are shorted and need replacing, the following points should be followed:</p> <p>(1) Replacement transistors should be of the same make and color code as those removed. The color coding is done at the CROWN factory and insures that the paralleled outputs will share the load equally by keeping the Vbe values closely matched. The testing is done on the curve tracer with the following conditions:</p> <table border="1" style="margin-left: auto; margin-right: auto;"> <thead> <tr> <th colspan="2">Vce=4 volts</th> <th>Ic=3 amps</th> </tr> <tr> <th>Vbe</th> <th>Group</th> <th>Color</th> </tr> </thead> <tbody> <tr> <td>.8-.99v</td> <td>A</td> <td>Red</td> </tr> <tr> <td>1.0-1.19v</td> <td>B</td> <td>Orange</td> </tr> <tr> <td>1.2-1.39v</td> <td>C</td> <td>Yellow</td> </tr> <tr> <td>1.4-1.59v</td> <td>D</td> <td>Blue</td> </tr> <tr> <td>1.6-1.79v</td> <td>E</td> <td>Violet</td> </tr> <tr> <td>1.8-1.99v</td> <td>F</td> <td>White</td> </tr> <tr> <td>2.0-2.19v</td> <td>G</td> <td>Green</td> </tr> <tr> <td>2.2v</td> <td>--</td> <td>Reject</td> </tr> </tbody> </table> <p>A, F, and G are rare groups. E, F, and G should only be used for positive outputs. A, B, C, and D can be used for positive or negative outputs. Unless matched transistors are used the load will not be equally shared and the member of the pair forced to carry the larger share of the load will eventually give up the ghost: maybe sooner, maybe later.</p> <p>(2) Be careful to include all insulating materials from the origi-</p>	Vce=4 volts		Ic=3 amps	Vbe	Group	Color	.8-.99v	A	Red	1.0-1.19v	B	Orange	1.2-1.39v	C	Yellow	1.4-1.59v	D	Blue	1.6-1.79v	E	Violet	1.8-1.99v	F	White	2.0-2.19v	G	Green	2.2v	--	Reject
Vce=4 volts		Ic=3 amps																														
Vbe	Group	Color																														
.8-.99v	A	Red																														
1.0-1.19v	B	Orange																														
1.2-1.39v	C	Yellow																														
1.4-1.59v	D	Blue																														
1.6-1.79v	E	Violet																														
1.8-1.99v	F	White																														
2.0-2.19v	G	Green																														
2.2v	--	Reject																														

Symptoms	Possible Causes	Service Procedure
Fuses blow (no Load)	Output transistors shorted(Q2, Q3, Q5, Q6)	<p>nal transistors on the replace. ments. These may include insulation on mounting screws, insulation around emitter and base leads, insulating washers on mounting screws, a large nylon insulator covering the holes for the mounting screws and the transistor leads or an insulating washer between the transistor case and the heat sink. (On some units, enumerated in the change list, the heat sinks have been coated with an insulating film, removing the need for the insulating washers that were formerly used under the transistor cases.)</p> <p>(3) Be sure the transistors replaced are adequately heat-sinked by using a good heat conducting compound (such as Dow-Corning 340) on the transistor case where it fits against the heat sink, and by tightening down all mounting screws evenly.</p> <p>(4) Be sure all base and emitter leads are securely soldered when new transistors are mounted. These leads are in a fairly inaccessible place, and soldering is a nuisance. The leads also may have an oxide coating which keeps them from taking solder easily.</p>
	Diodes CR7 and CR8 shorted (rare event)	<p>As described above the resistance across the output transistors will show a low value--from a few tenths of an ohm to several ohms (shorted diodes have shown up to ten ohms) If the outputs have been eliminated as culprits by the test outlined above, unsolder one end of each of the suspected diodes and check their reverse resistance with an ohmmeter. It should be high enough to cause no deflection on the R X 1 resistance scale. Otherwise, replace the diode.</p>
	Driver transistors Q1 and/or Q4 shorted (very rare event)	<p>The test of the outputs should show about 5-6 ohms. When it has been established that this is not due to a shorted diode, check the resistance</p>

Symptoms	Possible Causes	Service Procedure
Fuses blow no load	<p>Driver transistors Q1 and/or Q4 shorted (very rare event)</p> <p>Pre-driver transistors shorted (Q111 and Q114)</p> <p>Supply shorted to ground (usually only one supply will be shorted so only one fuse should blow)</p>	<p>directly across the collector-emitter leads of the driver transistors with the ohmmeter. If this shows low resistance or a short (still using the low voltage probe), unsolder the driver leads and check again. If the short remains, replace the driver(s). If the short goes away with the leads unsoldered, check the base-collector junctions of the outputs.</p> <p>Both of these are <u>not</u> likely to short at once. If they do, drivers and outputs are also likely to be shorted. At any rate, a measurement across the collector-emitter leads with the low voltage ohmmeter should show a very high reading if the transistors are okay. A low reading indicates a shorted pre-driver or a shorted base-collector junction in the driver. The second of these possibilities is less likely.</p> <p>Check supply-to-ground resistance on the R X 1 ohms scale. Normally this should not cause a deflection. (with the fuses out) If there is a measurable resistance then something is conducting to ground. Trace the shorted DC supply line from the outputs back toward the input of the amplifier. Isolate the problem by disconnecting wires in succession.</p> <p>EXAMPLE: The +60v line in Ch2 shows a short to ground. Disconnect the red +60v lead between the output transistors and the circuit board. Continue the search on the side of this connection where the short still appears.</p> <p>NOTE: Capacitors C106, C112 and C6 on the +60v supplies are damaged sometimes by power surges when fuses blow, as mentioned above. These are likely candidates as sources of shorted +60v supplies.</p>

At this point in the repair process the amplifier should be capable of sitting quietly with no load or signal and keeping all of its fuses intact. The next step is to discover if the unit will properly amplify a sine wave. Turn up the level control (with the signal source and output monitor plugged in) and observe the results at the output. The waveform should appear undistorted at all amplitudes until it clips. Clipping should be sharp with no ringing or other oscillation. If any of this is not true, check the following service chart.

Symptoms	Possible Causes	Service Procedure
Continuous DC voltage at output	Shorted transistors or diodes in output circuitry	Use the procedure described above for the situation where both sides of the output are shorted. If the offset is positive--check the positive side, if negative--check the negative side.
	Bad connections	Visually inspect for loose wires and loose transistor leads, especially on the circuit board. As a general procedure use a voltmeter to compare voltage readings around the circuit with those given on the schematic. Beginning at the input, move stage by stage through the amp trying to account for any large deviations from the suggested quiescent voltage levels. As was emphasized earlier, look for abnormal situations and determine whether or not components are actually bad or whether they are only responding to an abnormal situation created by a problem elsewhere.
	Shorted or open components in the input stages. +20v zener supplies	(The components most often having problems here are Q102-Q109 and CR101-CR104.) Check the +20v levels with a voltmeter--they should generally be within a volt or two of this designated value. (Older units may be a few volts lower, due to the use of other zener diodes.) If one supply is low, try to determine where the current to that supply is going:

Symptoms	Possible Causes	Service Procedure
Continuous DC voltage at output	Shorted or open components in the input stages. $\pm 20v$ zener supplies	<p>(1) The zener (CR103 or CR104) may be defective and unable to hold the voltage.</p> <p>(2) Occasionally C111 and C105 have been mounted backwards. In this case they are liable to break down eventually (and unpredictably) and short one of the zenered supplies to ground. Use 1.5v ohmmeter to check the forward and reverse junction resistance of the diode in question. This will ordinarily tell if there is anything wrong with the diode. It should show normal forward breakdown resistance and large reverse resistance while still in the circuit. If an abnormal reading shows up, pull one end loose from the circuit board and measure again to be sure the problem is not in the parallel 1 mfd capacitor.</p>
	Transistors	<p>Look at the voltages around the input stages. If the output is offset, these should be unbalanced with one side (Q101a-Q105 or Q101b, Q106-Q109) conducting while the other side is turned off. The voltage check may reveal a bad component: (for example: it may show that there is a forward biased junction that is not conducting, or a transistor biased off but still conducting, etc).</p>
	Shorted or open input transistors	<p>If it is not clear from the voltage check that a component is bad, turn off the power and use the ohmmeter (1.5v) to check individual transistors and diodes for proper junction resistances. Measurements significantly higher or lower than the normal values (taken from a good channel) indicate that the part should be replaced.</p> <p>The differential transistor (Q101a/b) almost never causes this kind of trouble.</p> <p>Q102 and Q109 are the next least likely to give trouble.</p> <p>Q103, Q104, Q105, Q106, Q107, Q108 cause most of the grief either by</p>

Symptoms	Possible Causes	Service Procedure
Continuous DC voltage at output	Shorted or open input transistors	shorting or by having a junction open up. The bias diode (CR101/102 double diode) may go out with Q106 or with Q107 or all by itself. This diode should show 70-80 ohms forward resistance while in the circuit.
	Limiter transistors (Q112 & Q113)	Use an ohmmeter to check Q112 & Q113. If either of these becomes leaky, or is shorted, the bias to the pre-driver is interrupted and the output becomes unbalanced. Compare the resistance measurements with those taken from a good channel. NOTE: The forward resistance of the base-emitter and base-collector junction of the transistors being used for Q112 varies from 10-50 ohms. Most of these will be in the 15-30 ohm range, but some which are good will be outside this.
	Bias diodes (CR105, CR108)	If one of the bias diodes opens up, creating runaway bias current, the output will be locked at the 60 volt level. The diodes should be checked with an ohmmeter for proper junction resistance. CR105 is a germanium diode and will show a lower forward resistance than the others. The double diode CR107/108 should show about 100 ohms forward resistance.
Intermittent DC voltage at output	Loose connections	With the unit turned on, tap gently on components (with some non-conducting piece of equipment that will not cause sparks, short circuits or bad feeling--like wood plastic, rubber or polyurethane, etc.), while observing the output. Look for a recurrence of the offset. If it happens as a result of this mechanical shock the odds are good that the source is a loose lead. Again a visual check is worth doing--especially on the underside of the board.
	Input transistor junctions opening up from heat	With the unit turned on, observe the output while heating up transistors Q103, Q104, Q107, Q108 in

Symptoms	Possible Causes	Service Procedure
Intermittent DC voltage at output	Input transistor junction opening up from heat	turn, with a small soldering iron. If one of these transistors is causing the difficulty, the offset should appear and disappear with alternate heating and cooling of the guilty transistor.
Oscillation at the output with or without signal	broken leads	Trace ground leads at input jack, level control pot, circuit board, protection switch and output terminals. Check wiring from board to heat sink for good solder joints at both ends (these wires sometimes break at the board or at the heat sink from flexing during removal and replacement of the circuit board.)
	Loose connections	Follow the procedure described above for locating parts causing offset voltages, tapping on the components and watching the output for changes.
	Defective components	Heat and cool (with small soldering iron and circuit cooler spray) components while observing the oscillation on the scope. Do this to the components on the board concentrating on transistors, diodes, and precision resistors. Components which significantly affect the oscillation when treated this way may or may not be causing the oscillation, but if one component seems to affect the oscillation more than any other, it should be the first candidate for replacement. Check capacitors by paralleling them with other capacitors of the same size. If this knocks out the oscillation, then the capacitor being checked may be open. Check other components (such as diodes or resistors) by paralleling them with capacitors. This may help to narrow down the source of the problem by showing where the oscillation is developing. (of course oscillations can also be caused by this technique)

Symptoms	Possible causes	Service Procedure
Distortion of signal at output	Loose connections Semiconductors	Proceed as described above--make visual check and tap on components. Who knows what you may find? Occasionally transistor or diode junctions will break down at a certain level of operation, causing weird and generally unpredictable distortion in the output signal. Resistance measurements and DC levels should not be affected, so the source of the trouble may be very difficult to detect. A scope probe may be some help in locating the difficulty--also luck.
Output unstable when level pot is adjusted	Internal contacts of level pot dirty	Temporary relief can be had by turning the pot back and forth repeatedly to allow the contacts to clean themselves. Permanent relief demands a new pot.
Positive half of output does not reach full amplitude and shows ringing	120 volt bootstrap supply defective	If only one channel shows the problem, check the connections at the ends of the 120 volt wire (yellow) to that board. Check the components (esp Q112 and CR109) of the 120 volt bootstrap circuit on the board with an ohmmeter. If both channels are low, check the 120 volt supply board (fig. 9): Check all solder joints; check diodes CR5 and CR6 for proper resistance; check C1 & C4 with an ohmmeter for shorts or leakage..

CHECKOUT PROCEDURE #3: 1KHZ SIGNAL--WITH LOAD

At this point the amplifier should perform acceptably with no load. Meaning that it should turn on normally with no damage to fuses or personnel, and it should properly amplify a 1KHZ sine wave without folding, bending, spindling, or mutilating it. Most of the common service problems will have been encountered by the time this test comes up. Depending of course upon individual luck and circumstances, the rest of the checkout should go easily.

For this and succeeding steps in the checkout, the following

NOTES SHOULD BE FOLLOWED:

NOTE ON LOAD: The load should be resistive, having less than 10% reactive component at any frequency up to five times the highest test frequency. The resistor should be capable of continuously dissipating the full output of the amplifier while maintaining its resistance within 1% of its rated value. The load should employ only high-current connectors (if any) and be connected to the binding-post output terminals. All output measurements should be taken at the amplifier output terminals, and not anywhere along the output cable through which the load current is flowing.

A dummy load with these characteristics is available from CROWN, as mentioned in the section on equipment.

NOTE ON VOLTAGE MEASUREMENT: Accuracy in measuring voltages for computing wattage is critical. For example, a 2% voltage error together with a 1% resistance error can result in an error of 10 watts power into 8 ohms.

If the bias level has been properly set (see pp. 15-16), the amplifier now qualifies for checkout under load.

- 1) Connect an 8 ohm load to the output
- 2) Monitor the output with an oscilloscope and an accurate AC voltmeter
- 3) Connect a sine wave oscillator set at 1 KHZ (+10db out) to the input
- 4) Turn up the level control of the channel under test

The output must clip at over 150 watts. Typically the clip point is 190 watts (39 volts) or above, with the AC line at 120 volts. The waveform should be clean, and should clip evenly and symmetrically with no ringing.

This test does not usually turn up problems that have not been seen before. If any do show up here, a likely source would be the output stages, since this is the first test where these stages are actually put to work.

For example, an oscillation occurring only with the load connected

may result from a defective capacitor on the output terminals. (C5)
 In general, however, problems which occur in this stage of the testing
 also occur with no load.

CHECKOUT PROCEDURE #4: PROTECTION CIRCUITRY (Four and two ohms)

This step tests the amplifier response to 4 ohm and 2 ohm loads.
 The level of the signal should be set at 150 watts or 34.6 volts
 (into 8 ohms).

Switch the load to 4 ohms while observing the output. The 4 ohm
 load should not affect the shape or amplitude of the output waveform.
 The amplifier is designed to handle a 4 ohm load. If 5A fuses are in
 the DC supplies, they will depart if the test is sustained for several
 seconds, so do this reasonably quickly.

The limiter test comes next. Be sure the protection switch is
 in the "N" (normal) position. Momentarily switch the output to the 2
 ohm load. The signal should clip somewhere in the range of 5-13 volts,
 positive and negative, and should remain reasonably symmetrical
 about zero.

Throw the protection switch to the "H" (hysteresis) position and
 again apply the 2 ohm load for a moment (holding in the 2 ohm load for
 more than a few seconds will also blow fuses; doing the test quickly
 gives the essential information needed and saves fuses.) The clipping
 should now occur in the 15-30 volt range. The clipped waveform should
 appear as (fig. opposite) differing only in amplitude for the normal
 and hysteresis modes.

When the test is done, reset the protection switch to the normal
 position.

Symptoms	Possible Causes	Service Procedure
Signal clips on 4 ohm load	bad connection on protection switch	Inspect switch SW-2, using an ohm-meter to be sure the contacts are making and breaking properly. Visually inspect the switch for a bad ground.
Positive signal will not clip on 2 ohm load	Bad connection in positive limiter circuit.	Visually check solder connections and wiring on: Q112, CR110, R127, R128, R133, R134, R4d, R4e, SW-2.

2. PROTECTION CLIPPING

2 Ohm Load

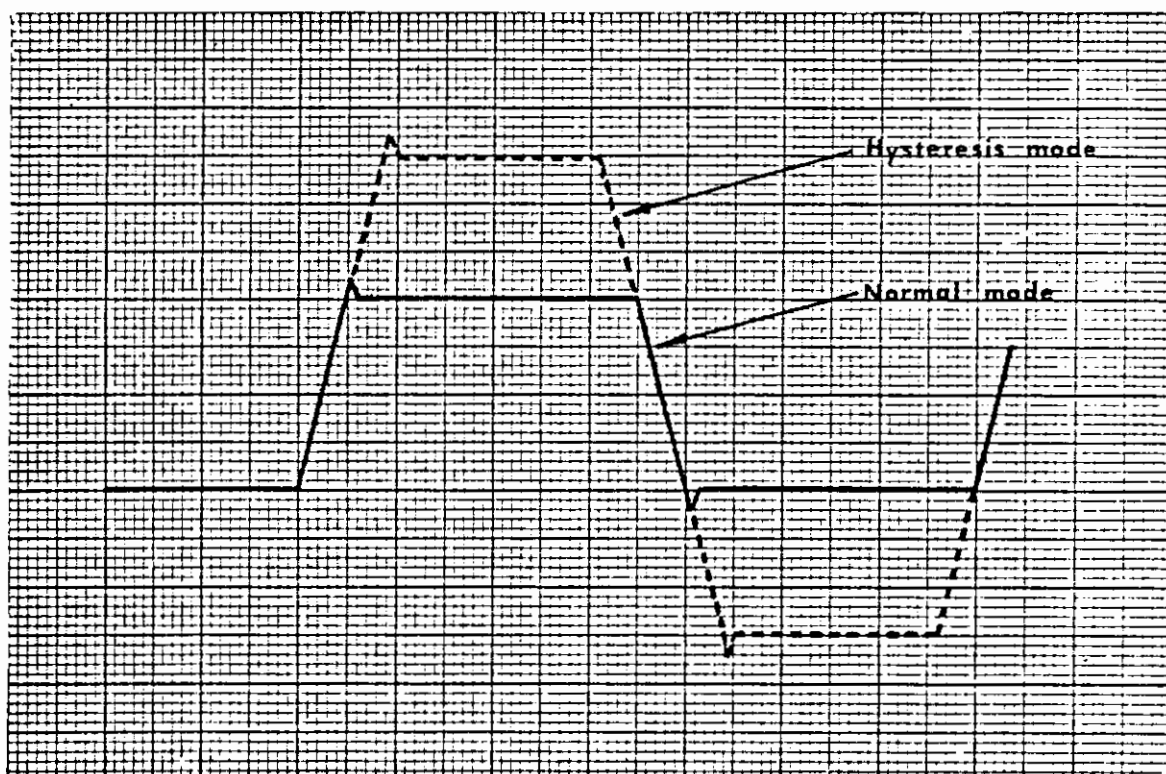

3. 20 KHZ SINE WAVE TEST

To be acceptable the waveform must show clipping at the peaks before it pulls in on the sides

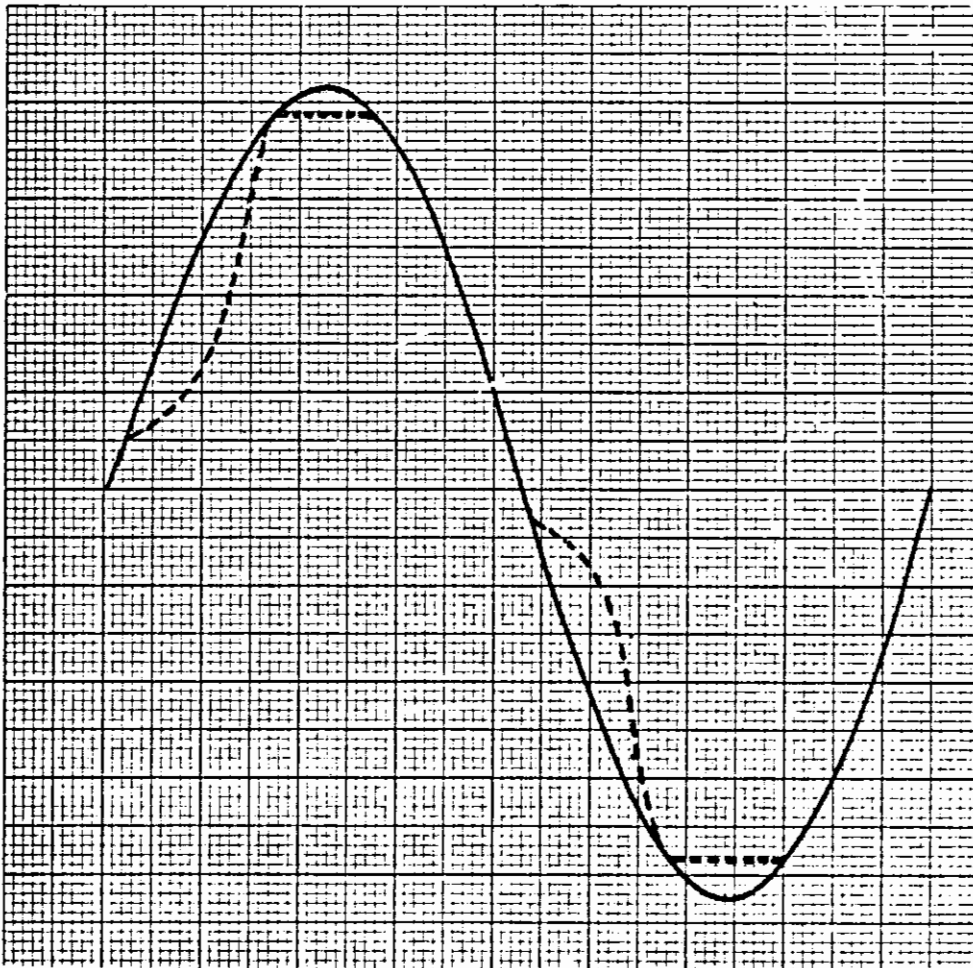

Symptoms	Possible Causes	Service Procedure
Positive signal will not clip on 2 ohm load	Failure of a semiconductor	Use an ohmmeter to check Q112 and CR110 for shorted or open junctions.
Negative signal will not clip on 2 ohm load	Bad connection in negative limiter circuit	Visually check solder connections and wiring on: Q113, CR111, CR112, RL29, RL30, RL35, R4c, SW-2.
	Failure of a semiconductor	Use an ohmmeter to check Q113, CR111 and CR112 for shorted or open junctions.
Either positive or negative clips at the wrong level on 2 ohm (either H or H mode)	Bad connection in limiter circuits or switch	Check connections as described above.

CHECKOUT PROCEDURE #5: 20 KHZ SINE RESPONSE

Set the oscillator at 20 KHZ. Turn up the level control until clipping occurs. The output into 8 ohms should clip at over 150 watts. A typical value is in the 180-190 watt range.

Two points should be made about this test:

1) The output must clip before it distorts in another way. For instance, if the limiter transistors are too sensitive, or the output transistors are too slow, the waveform will begin to pull in on the leading half of the positive and/or negative signals, before it clips on either end: The resulting waveform appears as in fig. opposite pp

The dotted line waveform is unacceptable. The amplifier is performing properly only if the output peak clips before any other distortion takes place.

2) This test should be made with the amplifier cold. As the transistors involved get warm, they slow down. The limiters turn on more readily and the problem noted above gets worse.

This test has not created any significant amount of trouble on units returned to the factory for service, so it is not likely to be a problem source. Of the transistors used in the outputs, RCA units are the only ones that have created problems by being slow to respond.

Earlier transistors used as outputs were faster but less dependable. With the slower RCA units, (and later, Westinghouse), capacitors C115 and C116 were increased from 50NF to 100NF to compensate for the decreased speed of the transistors.

CHECKOUT PROCEDURE #6: 10 KHZ SQUARE WAVE RESPONSE

Supply the input with a 10 KHZ square wave. With the amplifier level control at maximum, adjust the square wave generator to give a 40 volt peak-to-peak square wave. The output should be clean and sharp for all settings of the level control. "Clean and sharp" means a reasonable facsimile of the waveform in fig. opposite pg.

This test is another which is almost dull when doing service work. Once earlier problems have been handled, the 10 KHZ response usually follows meekly along. The official word here is that problems will not happen (until Murphy's Law takes its course.)

CHECKOUT PROCEDURE #7: INTER-MODULATION DISTORTION TEST

The connections for the IM test are shown in fig. opposite pg. The IMA should be calibrated according to the instruction in the IMA manual. The amplifier input level controls should be set to maximum for all distortion tests to assure repeatability of measurements. In making these tests it is important to know the residual distortion and noise levels of all test equipment, in order to accurately evaluate the amplifier.

The distortion is measured at 5db intervals from 150 watts output (28.6 volts) to 15 millivolts. At all points the distortion must be less than 0.1%.

NOTE ON AMP GAIN: The output signal should not vary significantly from 28.6 volts as the channels are switched. The gain of each channel is determined by 1% precision resistors, so the two should show the same gain. If they do not, the most likely source of trouble is the feedback loop. This problem is very rare, however.

Problems which occur in the course of this test are very often

5. IM DISTORTION TEST SET-UP

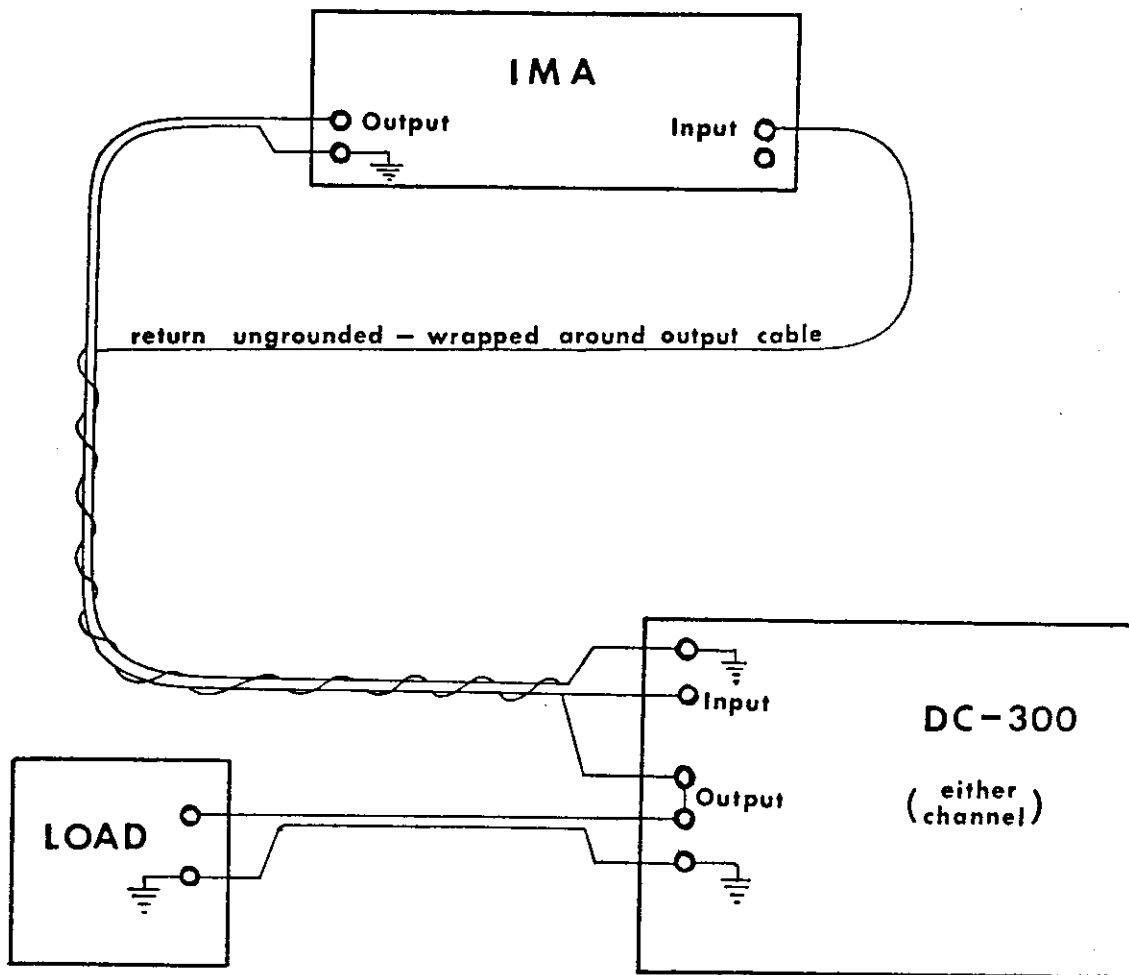

6. NOISE TEST SET-UP

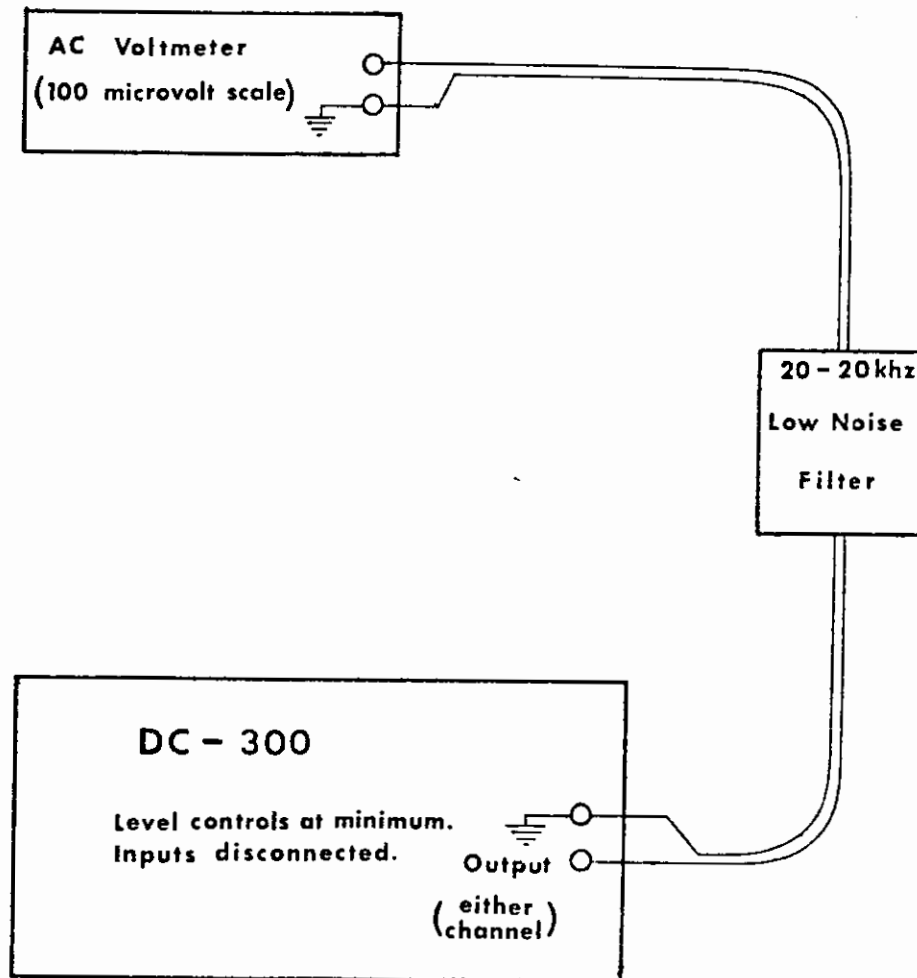

hard to trace. The larger and more obvious causes of trouble have been handled by this time and only the more subtle problems remain. The symptom of trouble, naturally, is an abnormal IM reading. For comparison, the table below gives the range of typical test results. There will be some variation of these measurements from channel to channel and from amp to amp. But the variations should be reasonable close to the usual pattern shown in the list. Any reading above 0.05% should be investigated, because ordinarily the distortion will not be this high (although this level is still only half of the specified maximum for the measurements).

<u>Typical IM Distortion</u>	<u>Test Readings</u>
150w	.020
47.5w	.010
15w	.005
4.75w	.005
1.5w	.008
475mw	.010
150mw	.015
47.5mw	.035
15mw	.025

<u>Symptoms</u>	<u>Possible Causes</u>	<u>Service Procedure</u>
High IM reading	High frequency oscillation	two of the remedies for this have already been incorporated into some of the amplifiers at the factory. 1) 47pf capacitors added across R115 (1.5K)(all amplifiers now being produced have these added) 2) .01pf mica disc added across the positive zener diode CR104 (this has been added only to those amplifiers which showed the oscillation during checkout.) (The oscillation will not normally occur unless the front panel has been mounted.)
	Poor soldering	Visually check all solder joints, especially around output and feedback circuitry.
	Deteriorating components	The most likely culprits here are precision resistors. The one which has caused the most grief is R119 (187K-1%) in the feedback circuit.

Symptoms	Possible Causes	Service Procedure
High IM readings	Deteriorating components	<p>Others to check are R113 (10K-15); R115 (43K-film); R105 & R111 (56K film).</p> <p>Heat the contacts with a small soldering iron--then cool with spray coolant. Look for significant changes in the IM readings resulting from this process. Components which do seem to affect the results significantly during this process are likely to be defective.</p> <p>Semiconductors or capacitors could also be causing high IM readings--but this has been less frequently a problem. The semiconductors can also be checked by heating and cooling. The capacitors can be checked by paralleling them with similar-sized capacitors.</p>

CHECKOUT PROCEDURE #8: DC BALANCE OF OUTPUT

For this step disconnect the inputs and turn the level controls to zero. Connect a DC voltmeter to each output in turn. The meter should be sensitive enough to detect an imbalance of a few millivolts. With the level pot at zero, set the output voltage to zero by adjusting the output balance pot on the circuit board. Then turn the pot to the 12 o'clock position and zero the output again with the input balance pot. The voltage should then remain at zero for all settings of the level control.

There has been only one consistent problem in this area with service units. Some differential transistors (Q101) have become unbalanced after use, so that the balance pots do not give enough control to restore the balance to zero. The solution is to replace the transistor.

CHECKOUT PROCEDURE #9: 20-20 KHZ NOISE TEST

Connect a sensitive AC voltmeter and filter (described in the equipment section of this manual) according to the diagram in fig. opposite pg .

For noise and hum measurements, all inputs should be discon-

4. 10 KHZ SQUARE WAVE RESPONSE

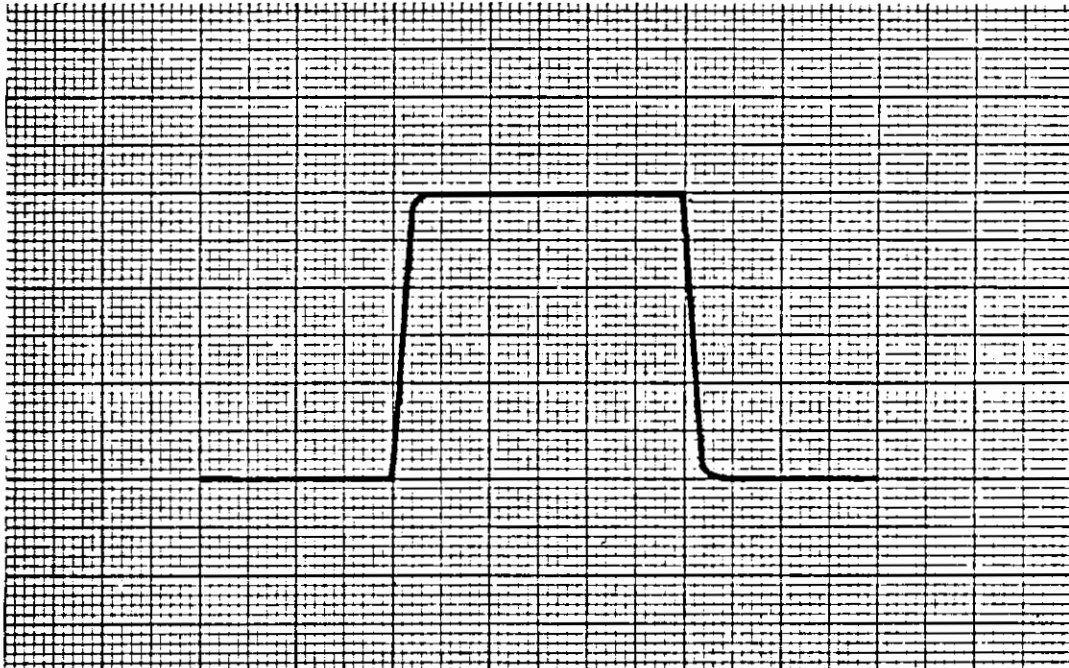

ected from the amplifier and the level controls set to minimum or to maximum, preferably minimum.

Never measure hum and noise when in the presence of strong magnetic fields. The amplifier should be at least 4 inches away from any large metallic objects or shield plates for a reading to be meaningful.

(Depending upon the way in which the different pieces of equipment are grounded together, it may be necessary to remove the output monitor jack from the channel not being tested in order to get an accurate noise measurement. Try this during the test to determine whether or not it has any significant effect on the noise reading.)

Measure the noise level relative to 150 watts (+33dbv). The specification is 100db below 150 watts. In practice, any reading that does not make 110db or better should be checked. A typical value is around 115db.

Sources of problems with the noise figure are often like those of the IM distortion test--subtle and hard to track down. Bad solder joints, poorly made grounds and components with bad contacts predominate as causes.

Symptoms	Possible Causes	Service Procedure
High noise level	Bad solder joints	For the 73rd time, visually inspect the defective channel to be sure all joints are securely made.
	Poorly made grounds	Check ground wires especially making sure they are well soldered. Check the output jack to make sure it is well grounded through the lock washer inside the chassis. Check the insulating washer on the input jacks to be sure they are properly in place. Check the lug holding the cables in place on the level control pot to be sure it is <u>not</u> touching the ground leads of the cables or ground terminal of the pot.
	Defective components	The differential transistor (Q101) occasionally will become noisy and need replacing. Using the heating and cooling method suggested above for other problems, check transistors, diodes, and resistors to see if any will affect the noise level when temperature changes.

CHECKOUT PROCEDURE #10: QUIESCENT POWER USAGE

Using a wattmeter, check the power used by the amplifier when it is turned on but carrying no signal. This power consumption must be less than 40 watts with the line at 120 volts. A typical reading is 25 watts. Problems at this point are rare and not usually complicated to solve when they occur. (only remember Murphy's Law)

Symptoms	Possible Causes	Service Procedure
Power drain too high (35 watts and higher)	Miswired transformer primary	Check the transformer wiring by comparison with the color code on the circuit schematic.
	Oscillations	Occasionally intermittent oscillations will not make an appearance until this point in the test. The high power consumption just means that one channel is turning itself on because of the oscillation. The procedure mentioned above for locating oscillation problems should be followed.

3. Mechanical Problems

Electronic problems are primary, but amplifiers also come back from customers with a variety of mechanical hurts that need repair as well. Unless the amplifier has doubled as a doorstop, the mechanical problems should be minor. Two in particular, however, can stand mention.

Loose Filter Capacitors C2 and C3: The two main filter capacitors on the +60 volt supplies are mounted by clamps inside the chassis in such a way that a good part of them protrudes from the rear of the chassis (on either side of the transformer). Because of this position the capacitors are subject to various unobtrusive pressures which conspire to push them the rest of the way into the chassis. On occasion (in fact, on many occasions) the mounting clamps have not been tight enough to withstand many of these pressures. As a result the capacitors have been pushed further into the chassis, forcing the circuit boards against the fuse chassis and doing various kinds of damage to components on the board. The remedy begins with pulling the capacitors back out until the top edge (inside the chassis) is even with the

upper edge of the mounting clamp. The clamp can then be tightened by tightening the screw holding the ends of the clamp. This particular screw has been cleverly placed so that an offset ratchet screwdriver, a small offset open-end wrench, fantastic dexterity, and seven boxes of patience are all you need to tighten it.

Loose Captive Nuts: This problem begins to make the amplifier sound like an adjunct to a mental hospital, but the actual problem is milder than that. The fuse chassis, the heat sinks, and the extrusion on the lower front of the amp have captive nuts mounted in them as part of our plan to hold the amplifier together. These sometimes come loose. Really. The thing to do when they come loose is to use a capscrew fitting the captive nut, with a washer on it to protect the amplifier chassis, to pull the nut into place again. Hold the nut in place while threading the capscrew into it from the other side of the hole. Torque the capscrew down with an allen wrench to reset the captive nut. In case the hole has been chewed up to the point where the captive nut will no longer lock in place, coat the inside of the hole with epoxy before setting the nut (be careful to keep the epoxy off the threads of the nut and capscrew, however, or you may have to do some blasting to complete the repair.)

PART V: PARTING SHOTS

When everything has been
said and done, there is
nothing left to say or do....

This manual is rapidly coming to an end. If it has been put together properly, it should provide a good start on solving the problems of most defective DC-300's. Possibly the manual has some weakness (the possibility has been estimated to lie between 97% and 100%) and so it will doubtless need some revision, appendices, expansion, etc, in the future. All of this will be easier if you people who read this will suggest your own preferences for revision. Maybe you will feel this manual should go right up there with Webster's Dictionary and Dr. Spock's Baby Book as a source of useful information. Or maybe you would rather think of it as you would a book of West Iranian Cookery: sort of interesting, but not much help. You may even think of it as the literary equivalent of last year's plane schedule: past all usefulness. Whatever way it comes out, think up your own conclusion and send it along to our service department. We would like to consider it in our future production of service manuals. If everything goes smoothly, we will produce an infallible service manual the day before we build an amplifier that will need no service.

Think of that.....

the end

Appendix A: Pictures and Diagrams

A- 1. OUTSIDE FRONT VIEW: DC-300

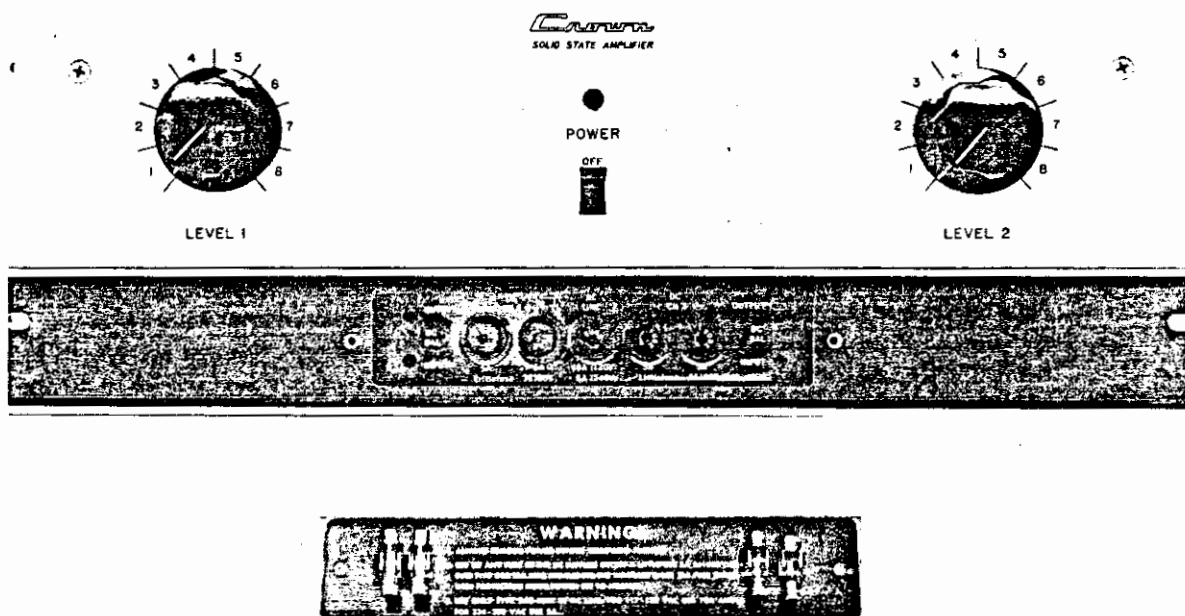

The picture above shows the following items:

- A. AC power switch—centered on the panel.
- B. Pilot light—just above the power switch.
- C. Level controls for both channels—to the right and left of the power switch.
- D. Access door with spare fuses—mounts on extrusion with thumbscrews to cover fuse panel.
- E. AC line fuse and DC supply fuses—AC line fuse in the center and two DC supply fuses for each channel.
- F. DC balance controls—access holes as marked at either end of fuse panel.

A-2. OUTSIDE BACK VIEW: DC-300

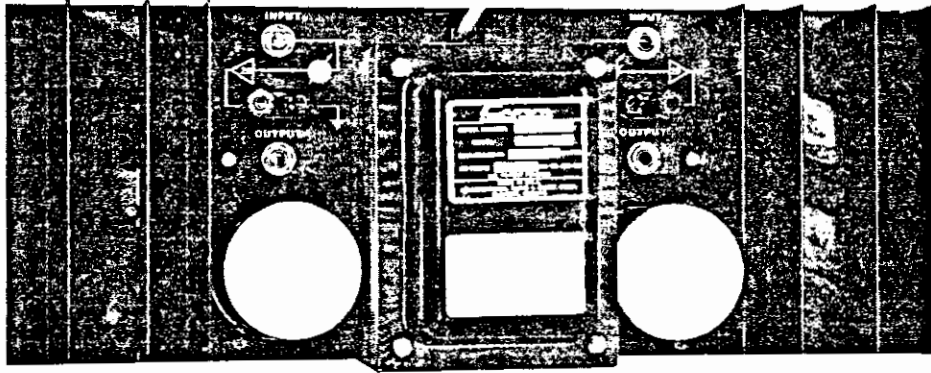

OLD STYLE: The picture above shows the back of the DC-300 for units through serial number A1498. Numbers A1499-A1698 have the mounting nuts and studs for the covers shown below, but not the covers themselves. The input and output phone jacks are clearly marked. The binding posts are alternate output connections. The output transistors, mounted in channels on the left and right, are covered with individual black plastic caps. The housing of the transformer displays the CROWN label with patent and serial numbers, as well as the warning label about output connections.

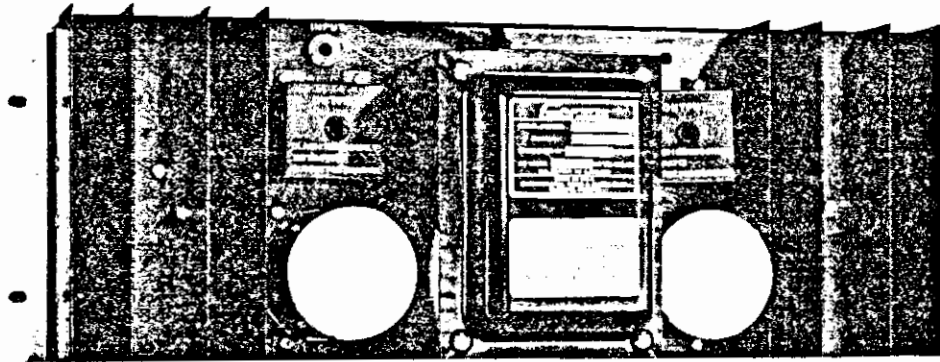

NEW STYLE: The new look began with number A1699. Observe that the output terminals are now covered with a small metal box labeled "output" (this can be removed to connect the output wiring). The purpose of the box is to eliminate the already remote possibility of electrical shock from the output binding posts. Also note that the transistors are now protected with metal covers instead of the black plastic caps shown in the top photo.

A-3. OUTSIDE END VIEW: DC-300

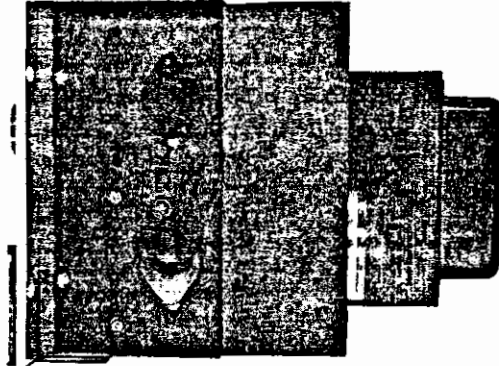

OLD STYLE: The photo above shows the protection switch of one channel, with the Hysteresis and Normal positions indicated by "H" and "N". The driver transistors also appear, covered with black plastic caps.

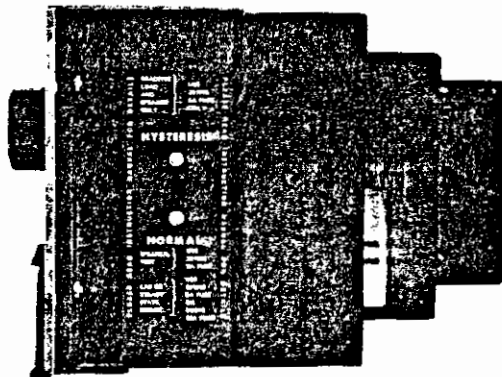

NEW STYLE: The photo above shows the changed appearance of the heat sinks, which began with number A1699. The driver transistors are protected with a metal cover, on which are printed the Hysteresis and Normal positions of the protection switch, as well as instructions about fuse usage (and an admonition, readable from two different directions, to please read the instruction manual).

A-4. CHASSIS INSIDE - WITHOUT HEAT SINKS

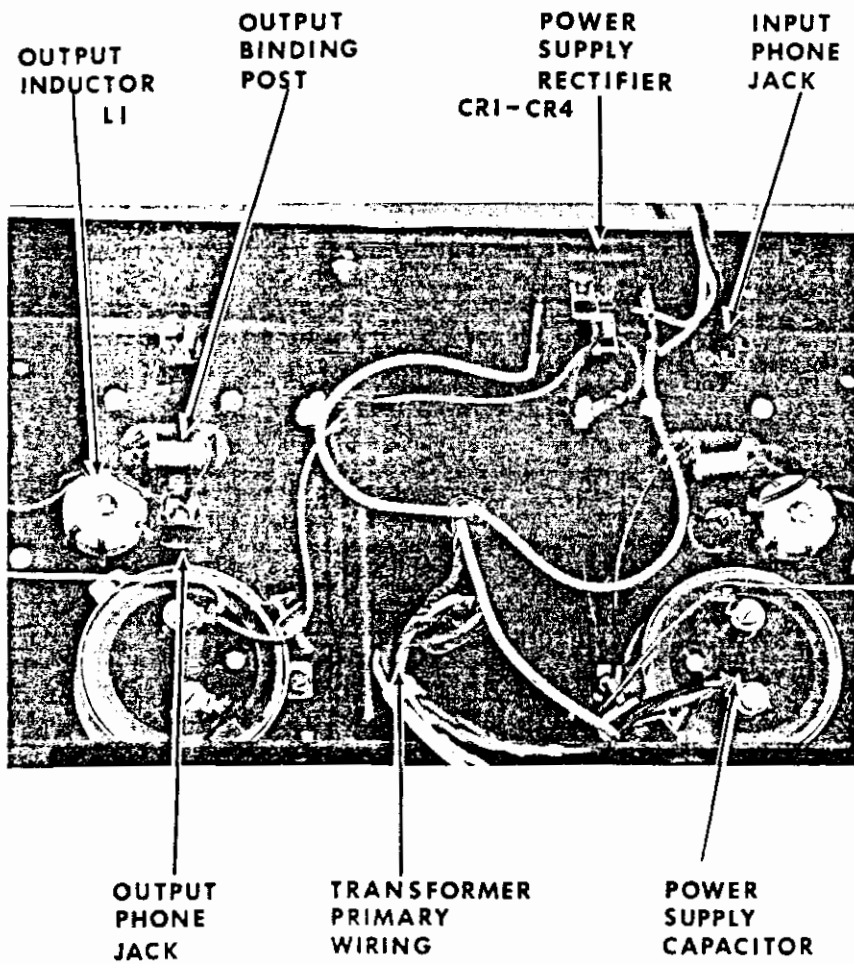

A-5. HEAT SINK UNMOUNTED

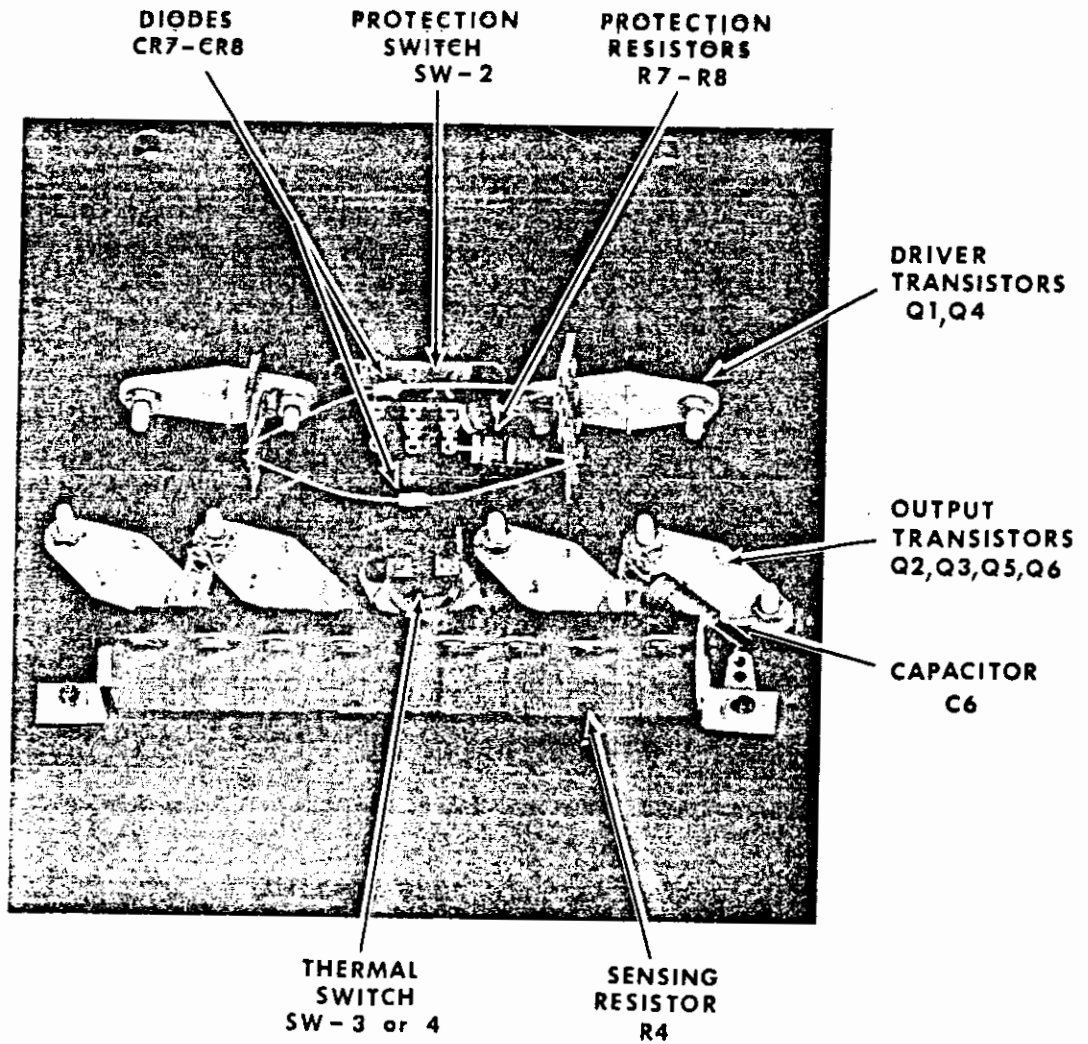

A-6. CHASSIS WITH HEAT SINKS MOUNTED

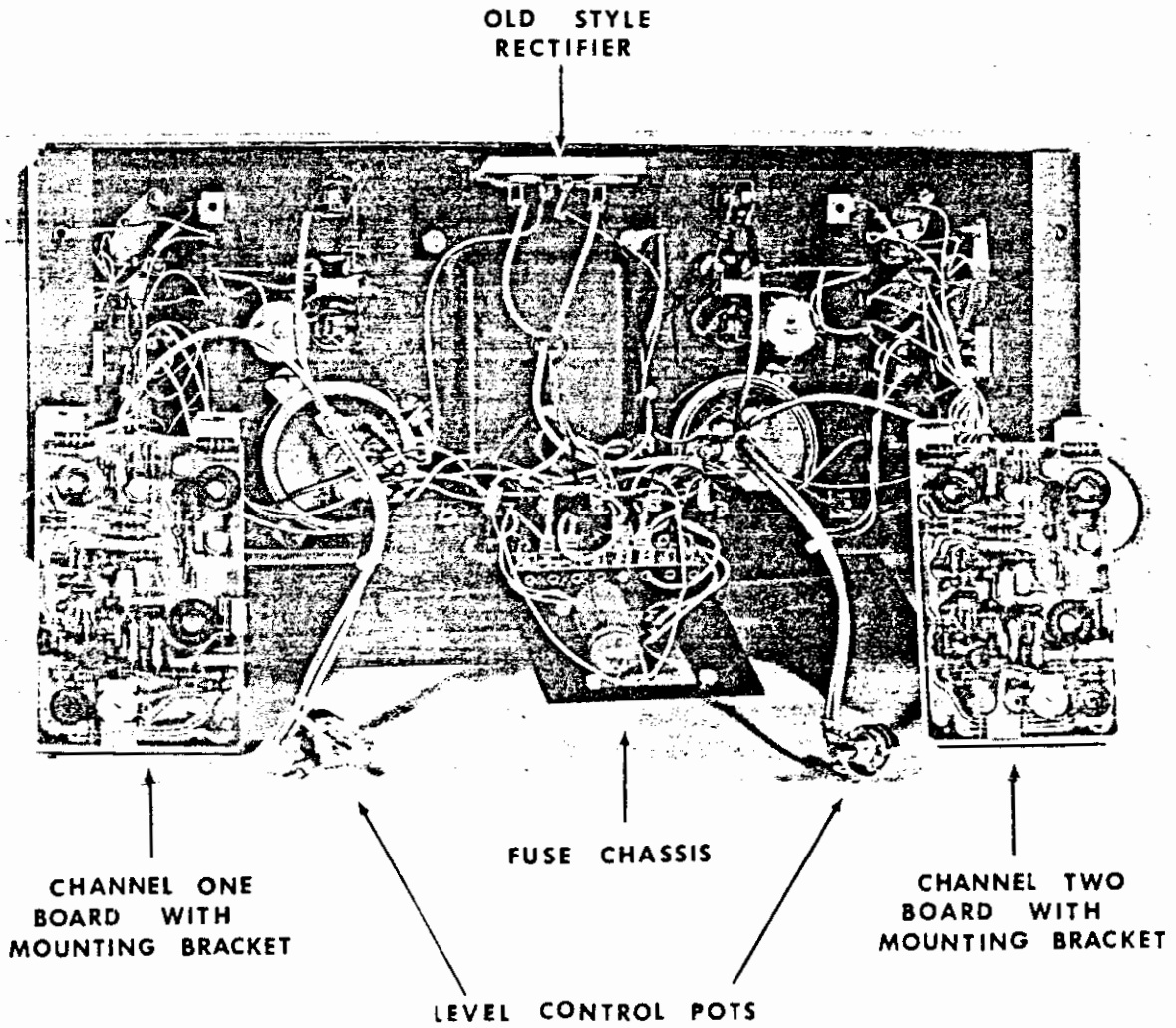

A-9. 120 VOLT SUPPLY BOARD

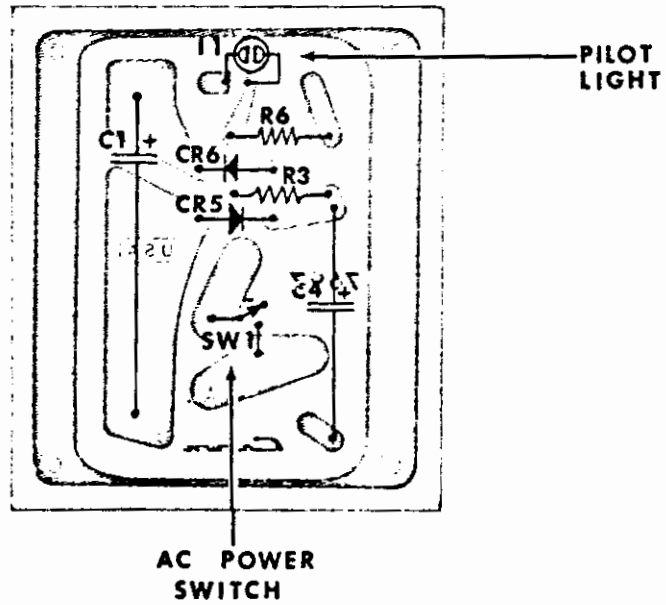

B. PARTS LIST

PARTS LIST

The following lists have been put together with the intention of making it a reasonable process to get replacement parts. They do not guarantee anything, but they will help move things along.

The organization comes from the illustrations. Each list is intended to include the significant parts (with accompanying information) shown in the corresponding illustration. The ideal procedure is to find the needed part(s) in one of the illustrations, then to look up the related information in the corresponding list. Simplicity itself.....theoretically.

Be it known to all that CPN does not mean Chocolate Plated Noodles or any of the other things that first crept into your mind. It stands for CROWN Part Number, and it is worth its weight in star sapphires when you think about ordering parts from us, because it helps identify and locate whatever parts are ordered. Aside from that it's just another number and not worth much at all.

The lists do not include wiring descriptions or specifications. These details should be easily obtainable from the unit being serviced, and it should then be easy to make up any needed replacement wires.

Descriptions of the hardware used with different parts are included with the parts, so that hardware misplaced during service or lost some other way can be conveniently replaced.

ILLUSTRATIONS 1-3

(pc = per channel)

Subassembly	Part Name	CPN	#Used	Other Information
FRONT PANEL	Panel	7682	1	
	Red lens & clip	2359	1	
	#1 broadcaster knobs	1577	2	
	Slide switch cap	2346	1	
	10/32 x 5/8 oval head screws	2120	2	Mounting front panel (upper)
	10/32 x 5/8 flat head screws	2825	2	Mounting front panel (lower)
	EXTRUSION	Extrusion	3396	1
8/32 captive nut		2018	2	Mounted in extrusion for accessory door screws
#8-15 x 1/2" oval sheet metal screws		2709	3	Mounting extrusion to chassis
Access door		2839	1	Mounts on extrusion to cover fuses and balance controls
SS module pipe clip		1727	4	These four together provide storage for 4 spare fuses
Fuse clip plate		3404	2	
GS-4-4 eyelet		2360	4	
Double sided tape (1/2")		1152	2	
8AG-5A fuse		1905	4	Spare fuse
Access door retainer		2917	2	Thumbscrews to hold accessory door in place
COVERS		Output covers	3252	1pc
	Hexco snap bushing	2412	1pc	

ILLUSTRATION 1-3

Subassembly	Part Name	CPN	#used	Other Information
COVERS	6/32 x 1/4" binding head phillips screw	1954	2pc	Mounting output covers
	Transistor cover-side	3234	1pc	
	Transistor cover-back	3235	1pc	
	6/32 x 1/4" binding head phillips screw	1954	4pc	Mounting screws for side and back transistor covers
	#6 lock washer	1823	4pc	On mounting screws for tran- sistor covers
RACK MOUNTING	10/32 x 5/8" oval phillips screws	2120	2pc	Screws for rack mounting amplifier
	#10 nylon panel washer (Black)	2119	2pc	
LABELS	Amplifier label (Cau- tion for outputs)	2881	1	Mounted on transformer. housing
	Cover label (Caution to prevent elect. shock etc.)	2862	1	Mounted on bottom of housing
	Amp # patent number	2949	1	Mounted on transformer housing
	H-N labels	2953	2	Used to mark normal and hysteresis positions of protection switches (on batches after #A2000, this information will be printed on transistor covers.)

ILLUSTRATION 4

Subassembly	Part Name	CPN	#Used	Other Information
CHASSIS	DC-300 Chassis	3594	1	
	6/32 captive nut	2019	3pc	Used for mounting heat sink (1) and output covers (2)
	Canoe clips	1726	1pc	Restrict movement of circuit boards
POWER CORD	3 wire line cord	2824A	1	
	Strain relief	2803	1	Feed-thru of line cord on chassis
	806 ground lug	3312	1	Ground lead of power cord to chassis
INDUCTOR (L1)	#16 brown wire 18"	2812	1pc	Wrapped on toroid to form output inductor L1
	Ferrite toroid form	2850	1pc	Foundation of inductor
	Nylon washers	2279	2pc	Inductor mounting
	6/32 x 1" binding head phillips	2138	1pc	
	6/32 nut	1889	1pc	
	#6 starwasher	1823	1pc	
	Type C loctite	2117	1pc	Lock nut to prevent inductor from working loose
INPUT-OUTPUT JACKS	Phone jacks	3423	2pc	Input and output phone jacks
	3/8" hex nuts	2046	2pc	Mounting phone jacks
	Shoulder washer (3/8")	1306	1pc	Insulation for input jack
	Flat fiber washer (3/8")	1646	1pc	"
	3/8" star lock washer	2188	1pc	Mounting output jack
	3/8" flat washer	2189	2pc	Mounting phone jacks
	TRANSFORMER	Transformer (T1)	3534	1
10/32 nuts		2829	4	Mounting transformer
#10 star washer		7892	4	"

ILLUSTRATION 4

Subassembly	Part Name	CPN	#Used	Other Information
RECTIFIER	MDA 990-3 rectifier- bridge (CR1,2, 3,4)	3333	1	
	Faston terminal	3298	4	Make connections to rec- tifier brigde
	Rectifier mount ing plate	2936	1	Straightening member of top center of chassis
	6/32 x 5/8 oval phillips screw	2207	1	Mounting rectifier
	6/32 x 3/8 oval head phillips screw	1871	1	Mounting plate
	Silicon com- pound	2422	1/2 tsp	Heat sink rectifier to mounting plate-to chassis
	6/32 hex nut	1889	2	Mount rectifier and plate
	#6 star washer	1823	2	Mount rectifier and plate
CAPACITORS	Electrolytic capacitor: 13,500mfd/70vdc (C2, C3)	3436	2	
	Capacitor clamp + hardware	2660	2	
	389 solder lug	2934	4	
	6/32 x 6/16" binding head phillips screw	2008	6-----	
	6/32 hex nut	1889	6	Mounting capacitor clamps
	#6 star washer	1823	6-----	
BINDING POST	Binding post	2823	1pc	Output terminals
	Type C loctite	2217		Prevent binding post from loosening under wear.

ILLUSTRATION 5

Subassembly	Part Name	QTY	#Used	Other Information
THERMAL SWITCH	Thermal switch (SW3, SW4)	2799	1pc	
	Heat sink	2826	1pc	
	10/32 captive nut	1334	2pc	Used to mount front panel
	Heat sink compound	2162		Insure good thermal contact between switch sensor and heat sink
	6/32 x 1/2" cap screw	2109	2pc	Mount thermal switch
	Brass standoff	3251	2pc	Serve as nuts on mounting screws and mounting points for transistor covers.
PROTECTION SWITCH	DPDT slide switch (SW2)	3247	1pc	
	6/32 x 1/2" cap screws	2109	2pc	Mounting protection switch
	Brass standoff	3251	2pc	Serve as nuts on mounting screws and mounting points for transistor covers.
TERMINAL STRIPS	1-G-2 terminal strip	1266	1pc	Terminal strips mount on transistor mounting screws
	2-G-1 terminal strip	1317	1pc	
	4.7K ohm 1 watt resistor (R7, R8)	2807	2pc	
	5mfd 70v capacitor (C6)	1678	1pc	From +60 to ground
	1N4005 Diode (CR7, CR8)	2851	2pc	
POWER RESISTOR	Power resistor (R4)	2766	1pc	Resistor clips mount on cap-screws used to attach heat sinks to chassis
	Resistor mount clip	3403	2pc	
	6/32 captive nut	2019	2pc	Set in resistor mounting clips
	505 solder lug	3163	1pc	Fits under mounting clip at upper (pos.) end of power resistor.

ILLUSTRATION 5

Subassembly	Part Name	CPI	#Used	Other Information
POWER TRANSISTORS	2N773 transistor (Q2,3,5,6)	3176 (West) 2964 (RCA)	4pc	Output transistors (Older units may have solution (2841) or Silicon Transistor Corp. (2841A) units as output transistors)
	MHT 7698 transistor (Q1,4)	2895	2pc	Driver Transistor
	T03 plastic film transistor	3180	2pc	Insulate driver transistors from heat sink
	T03 insulator	3179	6pc	Insulate all power transistor leads inside chassis
	6/32 x 3/4" binding head phillips	2135	12pc	Mounting drivers and outputs
	6/32 hex nuts	1889	12pc	"
	#6 lock washer	1823	14pc	"
	Heat sink compound	2162		Thermal contact between output transistor and heat sink
	Silicon compound	2422		Thermal contact between driver transistors and heat sinks
	505 solder lug	3163	4pc	Connecting output collectors together

ILLUSTRATION 6

Subassembly	Part Name	CPN	Used	Other Information
ATTACH H-S TO CHASSIS	6/32 x 1/2" cap screws	2109	3pc	Attach heat sink to chassis (1 captive nut set in chassis 2 others in power resistor brackets)
	Silicon com- pound	2422		Thermal contact between heat sink and chassis
	8/32 x 1/4" flat head phillips screws	2136	4pc	Attach heat sink to chassis (top and bottom)
LEVEL CONTROL	10K linear cermet poten- tionmeter (R1)	2922	1pc	(Includes 3/8" flat washer & 3/8" hex nut for mounting.)
	Wire & shield cable	1791	18" & 13"pc	Cabel from input jack to pot (13") and from pot to board (18")
	Panduit minia- ture tie	1811	3pc	Wrap cables together
	Zierick ground lug	2828	1pc	Lug is mounted on pot stem and then wrapped around cables to relieve strain on cable con- nections at pot terminals.
COMPONENTS ON OUTPUT- INPUT	2.7 ohm 1 watt resistor (R5)	1001	1pc	Parallels output inductor.
	2.7 ohm 1/2watt resistor (R2)	2857	1pc	Connects input ground to output ground
	.1mfd 200v mylar cap (C5)	2938	1pc	Across binding post terminals

ILLUSTRATION 7

The circuit board mounted on the fuse chassis is described in a separate illustration below:

Part Name	CPN	# Used	Other Information
Fuse mount sub-chassis	3395	1	
HEB fuse holder	1221	5	Includes hex nut for mounting
3/16 x 1/4" plugs	7723	4	Adapt fuse holders for shorter fuses (in DC holders)
8/32 captive nut	2018	2	Set in fuse chassis for mounting fuse chassis to main chassis
G6G terminal strip	1273	2	
6/32 x 3/16 binding head phillips screw	2008	2	Mounting terminal strips
#6 internal lock washer	1823	2	
6/32 hex nut	1889	2	
Fuse mount label	2846	1	Mounts across front of fuse panel to indicate fuse sizes, Etc.
8/32 x 1/4" flat head phillips screws	2136	2	Mount fuse sub-chassis to chassis

ILLUSTRATION 8

Part Name	CPN	#Used	Other Information
Board	7697	1	
27K ½ watt resistor	1056	1	
1.5K ½watt resistor	1076	1	
1N4003 diode (CR5, CR6)	2851	2	
10mfd 150v DC capacitor (C4)	2796	1	
80mfd 100v DC capacitor (C1)	1937	1	
NE2H neon bulb (1-1)	2500	1	Indicator lamp
SPST switch (SW1)	2835	1	AC power switch (mounted in center of board with 120v supply built around it)
¼/40 x ¼" round head slotted screw	1827	4	Mounting hardware
#4 internal star washer	1824	4	
¼/40 hex nut	1938	4	

ILLUSTRATION 9

This list has been made up according to the order of part numbers on the schematic, since it seems most likely that parts will be ordered after the schematic has been consulted.

BOARD MOUNTING:

Part Name	CPN	#Used	Other Information	
Board mounting bracket	40246	1pc	These include a rubber stem bumper in one corner and an insulating board glued to the bottom of the bracket (to keep from shorting the filter capacitor leads). Right and left hand boards have the rubber bumpers mounted in different corners (the bumpers replace the mounting screw in the corner where the balance post are placed--a mounting screw could short one of the pots)	
6/32 x 1/8" binding head phillips screw	2176	3pc	----- -----	
#6 star washer	1823	3pc		Mounting board to bracket
1/4" spacer	1840	3pc		
#8 x 5/8" sheet metal screw-hex head	2757	2pc	Mounting bracket to heat sink	

MAIN BOARD PARTS:

Resistors--per channel

Part Name	CPN	#Used	Other Information
R101 (1K 1/4W)	2627	1	
R102 (10K 1/4W)	2631	1	
R104 (1m 1/4W)	2805	1	
R105 (56K 1/4W)	2810	1 (of 2)	Film resistor
R106 (3.9k 1/4W)	2630	1 (of 2)	
R107 (2.2K 1/4W)	2628	1 (of 2)	
R108 (2.2K 1/4W)	2628	2 (of 2)	

Resistors-- per channel

Part Name	CPN	# Used	Other Information
R109 (5.6K 1/2W)	1042	1	
R110 (3.9K 1/4W)	2630	2 (of 2)	
R111 (56K 1/2W)	2810	2 (of 2)	Film Resistor
R112 (3.3K 1/2W)	1051	1	
R113 (1.5K 1/2W)	1076	1	
R114 (56ohm 1/2W)	1009	1	
R115 (43K 1/2W)	2944	1	Film Resistor (was 39K)
R116 (10K 1/2W)	1035	1	
R117 (470ohm 1/4W)	2626	1	
R118 (10K 1/2W)	2343	1	1% tolerance
R119 (187K 1/2W)	2822	1	"
R120 (8.2meg 1/2W)	2984	1	(was 10 meg)
R122 (100K 1/2W)	1027	1	
R123 (3.3K 1W)	2806	1	
R124 (68K 1/2W)	1612	1	
R125 (3.0K 1/2W)	1059	1	
R126	----	1	Value selected to adjust bias
R127 (5.1K 1W)	2808	1 (of 2)	5% tolerance
R128 (4.7K 1/2W)	1640	1 (of 2)	
R129 (4.7K 1/2W)	1640	2 (of 2)	
R130 (5.1K 1W)	2808	2 (of 2)	5% Tolerance
R131 (180ohm 1/2W)	1006	1 (of 2)	
R132 (5.6ohm 1W)	2355	1 (of 2)	5% tolerance
R133 (240 ohm 1/2W)	1069	1 (of 2)	5% tolerance
R134 (240ohm 1/2W)	1069	2 (of 2)	5% Tolerance
R135 (120ohm 1/2W)	2804	1	1% Tolerance (was 5%)
R136 (100ohm 1/2W)	1007	1	
R137 (180ohm 1/2W)	1006	2 (of 2)	
R138 (5.6ohm 1W)	2355	2 (of 2)	5% tolerance
R139 (18ohm 1/4W)	3057	1	

Capacitors--per channel

C101 (27pf)	2342	1
C102 (47pf)	3409	1 (of 2)
C103 (.047/200)	2977	1

Capacitors--per channel

Part Name	CPN	# Used	Other Information
C104 (.01 disc)	1751	1 (of 2)	
C105 (1/30 tantalum)	1750	1 (of 2)	
C106 (5/70)	1678	1 (of 2)	
C107 (10pf)	2821	1	
C108 (5pf)	2820	1	
C109 (.01 disc)	1751	2 (of 2)	
C110 (.1mfd 200v film)	2938	1	
C111 (1/30 tantalum)	1750	2 (of 2)	
C112 (5/70)	1678	2 (of 2)	
C113 (3.9pf ceramic cap)	2937	1	
C114 (.0015 pacer)	3089	1	
C117 (.0047 film mylar cap)	3178	1	
C118 (200pf)	3411	1	
C119 (.1 ceramic disc)	2600	1 (of 2)	
C120 (.1 ceramic disc)	2600	2 (of 2)	
---(47pf)	3409	2 (of 2)	Added to circuit across R113 (1.5K) to solve some oscillation problems
<i>C121[↑] (47pf)</i>			

Diodes--per channel

CR101 & CR102 (MZ2361 double diode)	3039	1 (of 2)	
CR103 (1N968B Zener-diode)	3277	1 (of 3)	
CR104 (1N968B Zener)	3277	2 (of 3)	
CR105 (1N270 Germanium)	3447	1 (of 2)	
CR106 (MR2360)	2798	1	
CR107 & CR108 (MZ2361 Double diode)	3039	2 (of 2)	
CR109 (1N968B Zener)	3277	2 (of 3)	

Diodes--per channel

Part Name	CPN	# Used	Other Information
CR110 (1N4148)	3181	1 (of 2)	
CR111 (1N4148)	3181	2 (of 2)	
CR112 (1N270 Germanium)	3447	2 (of 2)	

Transistors--per channel

Q101 (A&B)(TD101)	2832	1	Differential amp transistor.
Q102 (2N3859A special NPN)	2961	1 (of 3)	
Q103 (2N5383 special PNP)	2982	1 (of 4)	
Q104 (2N5383 special PNP)	2982	2 (of 4)	
Q105 (2N3859A special NPN)	2961	2 (of 3)	
Q106 (40327 selected)	3348	1 (of 3)	
Q107 (2N5383 special PNP)	2982	3 (of 4)	
Q108 (2N5383 special PNP)	2982	4 (of 4)	
Q109 (2N3859A Special NPN)	2961	3 (of 3)	
Q110 (40327 selected)	3348	2 (of 3)	
Q111 (40327 selected)	3348	3 (of 3)	
Q112 (2N1304)	2721	1	
Q113 (2N1305)	2817	1	
Q114 (SS7304)	2923	1	

Other Parts Not Mentioned Above--per channel

Transistor pads	1250	6	
Printed circuit com- ponent receptacles	1655	2	
100K horizontal pot	1709	1	
1K horizontal pot	1711	1	

Other Parts Not Mentioned Above--per channel

L101

Part Name	CPN	#Used	Other Information
1 mhy Inductor	2441	1	
Transistor heat sink	3175	3	2225 B Therma Sink
Printed Circuit board	7558	1	With no parts Mounted

C. CHANGE LIST

CHANGE LIST

It will become obvious very quickly to the most casual observer (as well as to all alert, quick-minded, and diligent service personnel) that all DC-300's are not identical. There have been changes made not, as is commonly supposed in the heat of service work, to confuse the serviceman, but to improve the reliability and effectiveness of the amplifier.) Nearly all of the changes are reasonably minor (as opposed, I guess, to unreasonably minor?) and are simply the result of finding a better way to do something, or a more suitable component for a particular job, etc. The point of this section is the description of the most important of these changes in some detail, mostly for the purpose of distinguishing factory components from customer components, as well as for preventing confusion when similar parts from different amplifiers do not seem to match.

To make the section easier to use the changes are grouped under the different components or sections of the amplifier involved.

TRANSISTORS

1) Q2, Q3, Q5, Q6--Output Transistors (2N3773)

Four different brands of output devices have been used to date. The original outputs were made by Solitron. When these began to show less reliability than expected, RCA transistors were used on the following batches. The RCA units, although showing excellent reliability, were not as fast as desired and some had to be replaced on the check-out bench in order for the amplifiers to meet response specifications. Silicon Transistor Corporation had a faster transistor that they believed would be reliable under DC-300 operating conditions. It wasn't. After a smattering of STC units, the RCA transistors were reinstated, and the search for a faster (reliable) transistor went on. Westinghouse seemed to have the ideal unit to fill the need. Their transistor met all specifications and was faster than the RCA unit. The only hitch turned out to be a mechanical problem. The

bases of the Westinghouse transistors were slightly bowed and when the transistors were bolted to the rigid DC-300 heat sinks, the straightening process sometimes caused internal havoc with the semiconductor chip. The following batch of amplifiers went back to RCA outputs, while a procedure was developed to screen out the unusable Westinghouse units. With the use of this screening procedure, the Westinghouse units have become standard components at this point.

The division of amplifiers according to output brands is as follows:

Soliton (CPN 2841): A100-A236

STC (CPN 2841A): A465, A475, A478, A479, A483-A485, A488, A489, A494, A516, A526, A527, A540.

RCA (CPN 2964): A237-A464, A466-A474, A476, A477, A480-A482, A486, A487, A490-A493, A495-A515, A517-A525, A528-A539, A541-A552, A554-A1198, A1248-A1298, A1399-A1498, A1870-A1921.

Westinghouse (CPN3176): A553, A1199-A1247, A1299-A1398, A1499-A1869, A1922-A2048.

2) Q102, Q105, Q109--Input Stages:

Q102 and Q109 were originally SE4010 (CPN 2064A) transistors. Q105 was 2N3568 (CPN 2090). These were replaced in early production runs with faster 2N2859A special units (CPN 2961), which have been in use ever since.

3) Q103, Q104, Q107 Q108--Input Stages:

Initially these transistors were 2N3645's (CPN 2434). They were replaced during early production with special TZ581's (CPN 2982), in

order to improve the reliability of these stages. The 2982's continue in use.

4) Q114--Negative Pre-Driver:

This transistor was originally an ITCL504B0021 (CPN 2830). It was changed because the long number was slowing up our bookkeeping. Actually, the SS7304 (CPN 2923) replaced it because of a better price. and the 2923 incidentally improved the IM distortion readings of the amplifier.

5) Q110, Q111, Q106--Input Stage, Pos. Pre-Driver, 120 Volt Supply:

From the beginning these transistors have been RCA 40327's (CPN 2643). Beginning with amplifiers A1799, a gradual changeover is being made to RCA 61061's (CPN 3348). The new transistors are just 40327's selected for more efficient performance. Originally, CROWN did the selecting and tried to put the best units in positions Q106 and Q111 (Q110 is not as critical). The only change is that RCA now performs the selection process and puts a different number on the transistor.

DIODES

1) CR7, CR8--Flyback Diodes:

These diodes, mounted on the terminal strips inside the heat sinks, tie the positive and negative supplies to the output, so that the output potential can not go above 60 volts (plus the diode forward breakdown) in absolute value without pulling the supply voltage with it. Early units encountered problems with reactive loads which were destroying the output transistors by sending the output above the supply voltages. Units A100-A148 did not originally have these diodes installed (the diodes have since been added to many of these units when they have returned to the factory for one reason or another). All units from A149 on should have the diodes from the original manufacture.

2) CR107, CR108 CR101, CR102--Bias in Q105 and Output Stages:

Originally these were four discrete components. A need to raise the output bias voltage slightly, as well as the savings effected in using fewer components, led to the replacement of the MZ2360 diodes (CPN 2798) with MZ2361 diodes (CPN 3039). CR107 and CR108 were replaced by the double diode plus an 18 ohm resistor (for the desired bias increase) and CR101 and CR102 were replaced by the double diode. All units from A699 on should have this alteration.

3) CR103, CR104, CR109--Zener Diodes:

All three of these began as 1N967's (CPN 2103), which are 18 volt zeners with 20% tolerance. To solve a problem with tolerances, these were all changed later to 1N968A's (CPN 3056), which are 20 volts--10% tolerance. CR109, the value of which is less critical than the 20 volt supply values, was switched back to 1N967 for awhile. For several reasons, including a good price, all three have been recently changed to 1N968B's (CPN 3277), which are 20 volts--5% tolerance.

CAPACITORS

1) C6--From +60v to Ground:

Some early amplifiers had a problem with ringing at the positive clip point. The addition of this capacitor solved that problem. It also helped eliminate a low level 10 megahertz oscillation observed in some units. Beginning with A149, C6 was installed in all new amplifiers.

2) 47pf. Capacitor Across R113:

The low level high frequency oscillation mentioned above was annihilated in some units by adding a 10pf, 27pf, or 47pf capacitor across R113 (in the input circuit) at the test bench as needed. The percentage of units having the problem was high enough to justify adding the 47pf

capacitors to every unit and dispensing with the search for oscillation (since no units showed up which were not cured by the 47pc cap.). The circuit board has not been altered for this component and it is still soldered directly across R113 (1.5K).

3) C115, C116--Limiter Circuits:

With the Solitron and STC outputs, these capacitors were 50nf. But with the slower RCA transistors, the size of the capacitor was doubled in order to keep the overall response of the amplifier fast enough. At first other 50nf capacitors were added in parallel on the under side of the board, but later the 50nf capacitors were replaced with 100nf units in the board production. The Westinghouse transistors also need the 100nf capacitors, so they have remained.

4) C113--Across Feedback Resistor R119:

This capacitor began as a 1.5pf arrangement of inter-digitated foils on the circuit board itself. It was augmented by a 2.2pf capacitor soldered directly across the 187K resistor (R119). The two of these were shortly replaced by the 3.9pf capacitor which is still in use.

RESISTORS

1) R115--Emitter Resistor on Differential Input:

This began life as a 39K resistor. Early in the game it was discovered that variations in the zenered supplies sometimes left TD101 without enough voltage to insure an adequate signal swing. The size of R115 was increased from 39K to 43K to raise the voltage level.

2) R120--Output Balance Circuit:

This unit was changed in the early batches from 10meg to 8.2meg, in order to improve the range of the output balance pot.

POWER SUPPLY

Rectifier Assembly:

The rectifier assembly on the transformer secondary originally consisted of four discrete diodes mounted in aluminum bars. It has been recently replaced by an epoxy-cased bridge rectifier. This single component is both easier to install and easier to service than the original unit. The change was made on amplifiers from A1799 on.

MECHANICAL

1) Underwriters Lab Covers:

To comply with "safety" standards established by Underwriters Laboratories, the DC-300 has recently appeared with new metal covers over the chassis-mounted power transistors and the output terminals. These additions were provided for beginning with unit A1499. But due to late parts delivery, the first batches of the amplifiers went out with the mounting standoffs and mounting holes, but without the covers themselves. These units retained the plastic caps that are individually glued to the exposed transistor cases. Beginning with A1699, the amplifiers should have all of the new covers and labelling, including: covers for the output transistors, covers for the driver transistors, covers for the output terminals, and the cute little UL sticker on the transformer housing.

2) Change in Output Transistor Insulators:

In the original production, the output transistors (Q2, Q3, Q5, Q6) were insulated from the heat sink with an anodized plate. Later on a more efficient process was begun which involved spraying the area where the output transistors are mounted (on the back of the heat sink) with an insulating epoxy coating. This coating is not obviously visible but it can be assumed to be present when the insulating washers are not. (this is on the outside of the heat sink; inside the heat

sink nylon washers or plates are used as insulators for the mounting screws.) Please note that all driver transistors must be mounted with insulating washers, since there is no spray-coating on the ends of the heat sinks.

All units from A100 to A700's used separate insulators. Then the following units used the spray-on insulation:

A782	A794	A852	A869	A878
A785	A807	A857	A872	A879
A737	A841	A862	A873	A894
A789	A844	A866	A875	
A791	A847	A867	A876	

Units A899-A1198 followed with the old-style insulators.

Beginning with A1199 only A1218 and A1219 used the old separate insulators. All others since that point have used the spray-on insulation.

MISCELLANEOUS CHANGES

Besides the changes listed and detailed above, there are numerous others which have been left out of the list, because of their relative unimportance in doing any service work. These others include changes in style of capacitors, level control pots, input and output jacks, resistors, and germanium diodes. These parts have not changed in value or function, but only in the type used.

As explained earlier, the list has been put together for the purpose of avoiding confusion when parts of different amplifiers do not match and only those changes which we think may somehow get involved in service work have been detailed. Questions and confusions not cleared away by the information already given will have to be referred to the factory.

FIGURE D-3: DG-300 PROTECTION CIRCUITRY (SIMPLIFIED)

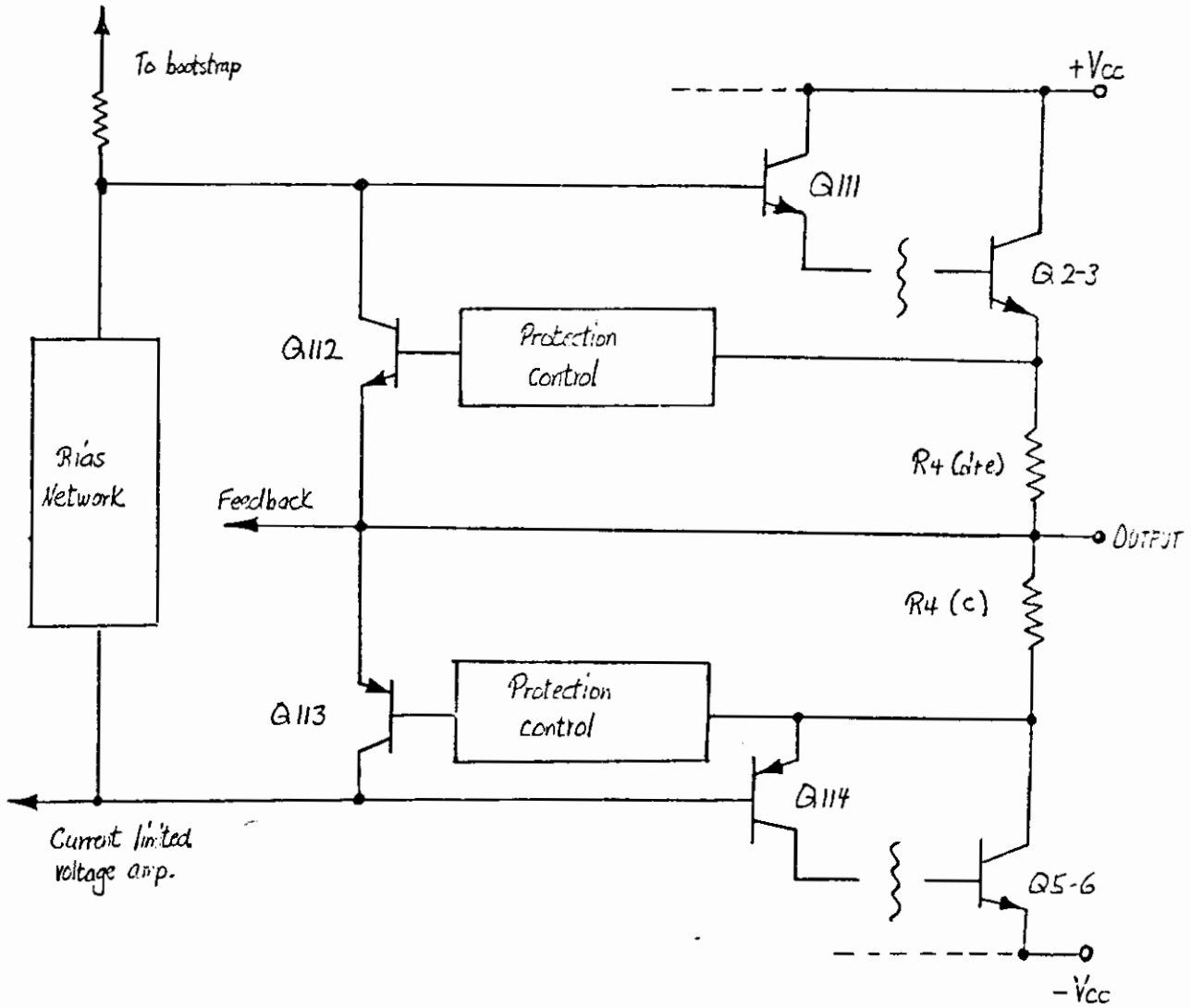

APPENDIX D: DC-300 Operation Theory

INTRODUCTION

Part I: Output Stages

- A. Design Objectives
- B. The CROWN AB+B Output Configuration
- C. Output Biasing

Part II: Protection Circuitry

- A. Design Objectives
- B. Overload Sensing
- C. Setting Voltage and Current Limits
- D. Hysteresis Mode Operation
- E. Additional Notes

Part III: Input Stages and Feedback Circuitry

- A. Design Objectives
- B. Differential Pair First Stage
- C. Emitter Follower Stages
- D. Grounded Base Stages
- E. Final Voltage Amplifier Stage
- F. Safety Features
- G. Feedback Circuitry
- H. Additional Notes

APPENDIX D: DC-300 Operational Design

INTRODUCTION

The following section has been written with the objective of explaining the basic operational features of the CROWN DC-300. The method of explanation involves dividing the amplifier circuitry into several sections and discussing the operation of each section individually. Three is a good number; it is not very big and not too small - so we have chosen three sections which are in the order of their appearance: (1) Output Stages; (2) Protection Circuitry; (3) Input Stages and Feedback Circuitry. Included with the text are simplified schematic drawings intended to clarify the way things work. One picture is worth a thousand words (which is why painters are richer than writers).

SECTION I: Output Stages

A. Design Objectives

One of the most persistently soul-twisting struggles occupying the tears and efforts of design engineers comes disguised as a power transistor. Output devices, by union rules, will either do your hard work for you in forty days and forty nights or they will do your easy jobs before the morning dew has dried. But none of them will work very hard and very fast at the same time, a situation which helps not at all in obtaining the basic qualities of a power amplifier (i.e. it should carry high power at high frequencies without obliterating itself). Given the selection of rugged, high-power, and discouragingly slow transistors on one hand, and fragile, low-power and super-fast units on the other, it would seem that some sort of combination might be arranged to exhibit the good qualities of both - a marriage of speed and strength. The objective, then of the DC-300 output stages, lies in compensating for the inadequacies of available output devices while making full use of their strong points.

B. The CROWN AB+B Output Configuration

Figure D-1 illustrates the CROWN solution to the problem of slow output devices. Basically, the configuration divides up duties so that:

FIGURE D-1 : DC-300 OUTPUT STAGES

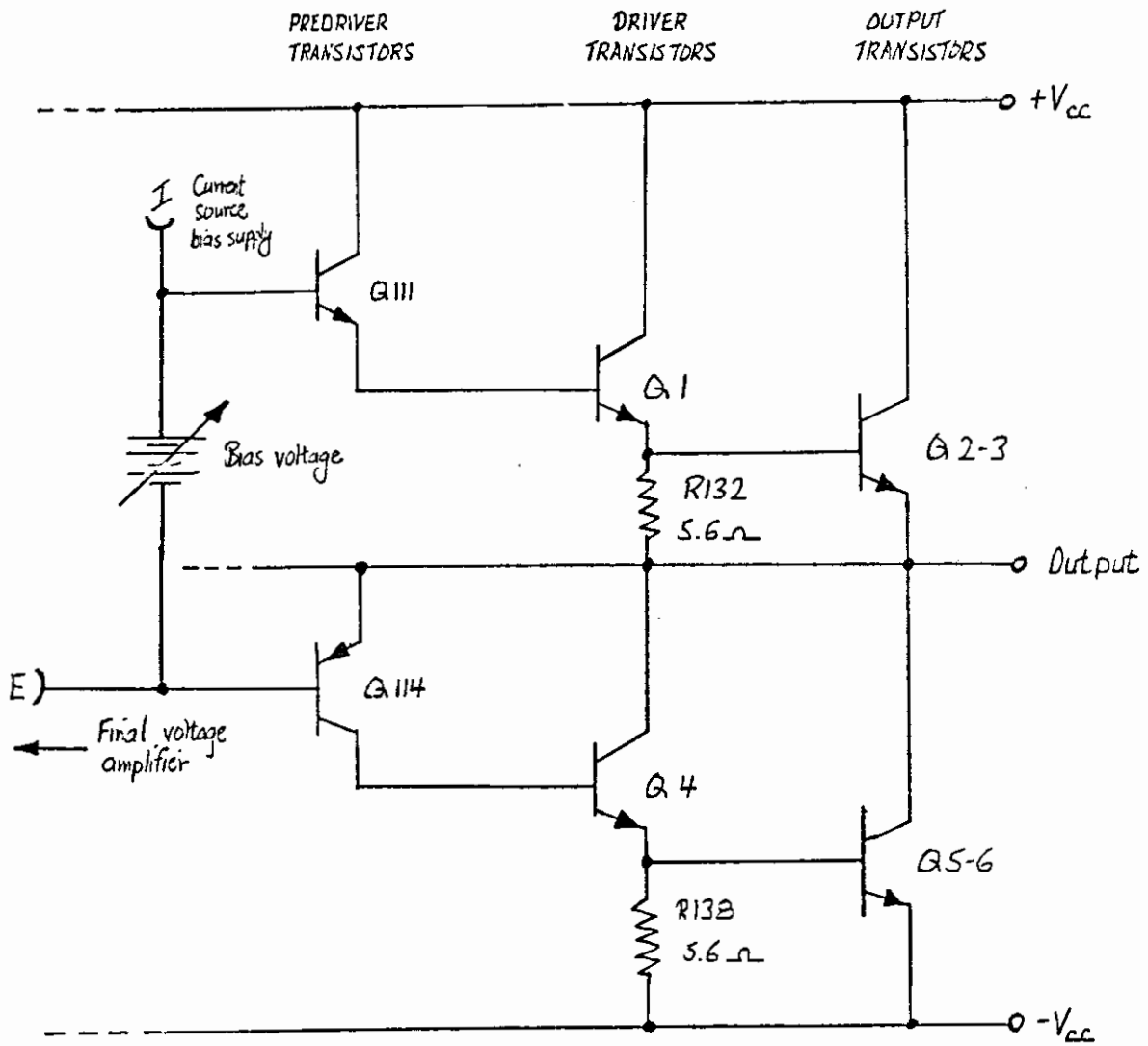

- 1) The rugged, slow output transistors are normally biased off and only come on when the load and signal demand significant amounts of current.
- 2) Fast, less durable driver transistors are normally biased on and handle all low level signals including the important crossover point when the output switches signal polarity.

The advantages here are obvious. The bias resistors on the outputs can be made small. This reduces the bad effects of their internal capacitance and allows the outputs to work better at high frequencies. There can be good low level linearity because the driver transistors which handle low level signals can be biased on all the time for quick switching. We thus combine speed and strength to provide previously unavailable performance.

Referring to Figure D-1, transistors Q2,3 and Q5,6 represent the output devices that draw no current in the quiescent state. Q1 and Q4 are the driver transistors which are biased on in the quiescent state. The bias current through the drivers does not induce enough voltage across output bias resistors R132 and R138 to turn the outputs on, but any demand for large amounts of current from Q1 and Q4 will quickly change the situation. When the current increases, the voltage across R132 and R138 will rise enough to turn on outputs Q2, 3, 5 and 6 and the outputs will supply the heavy currents demanded for high power operation. A further benefit of this design is

the gain in bias stability. Since the main outputs are normally biased off, there is no tricky adjustment or compensation necessary to keep them biased at the proper level. Overall, this use of AB+B operation maximizes the usable gain-bandwidth of an amplifier using currently available semiconductor devices.

C. Output Biasing

In Figure D-1, Q111 and Q114 are designated as predrivers. This complementary stage is cascaded with the driver stage to provide current gain sufficient to switch the output stages quickly and provide good performance at cross-over. The bias supply acts directly to bias this stage, which then biases the driver stage. The bias supply, as shown in Figure D-1, acts as a current source with adjustable voltage.

Figure D-2 shows more detail on the bias circuitry. Essentially the output of the final voltage amplifier supplies voltage to the predrivers, which then combine with the drivers and output transistors to amplify the current for final output power. The bias supply must properly set the quiescent operating levels of the predrivers, and must have enough voltage swing to handle the signal from the final voltage amplifier stage.

The load resistor (R125) of the final voltage amplifier (Q106) is bootstrapped by zener diode CR109 to the final

FIGURE D-2 : DC-300 BOOTSTRAP BIAS SUPPLY

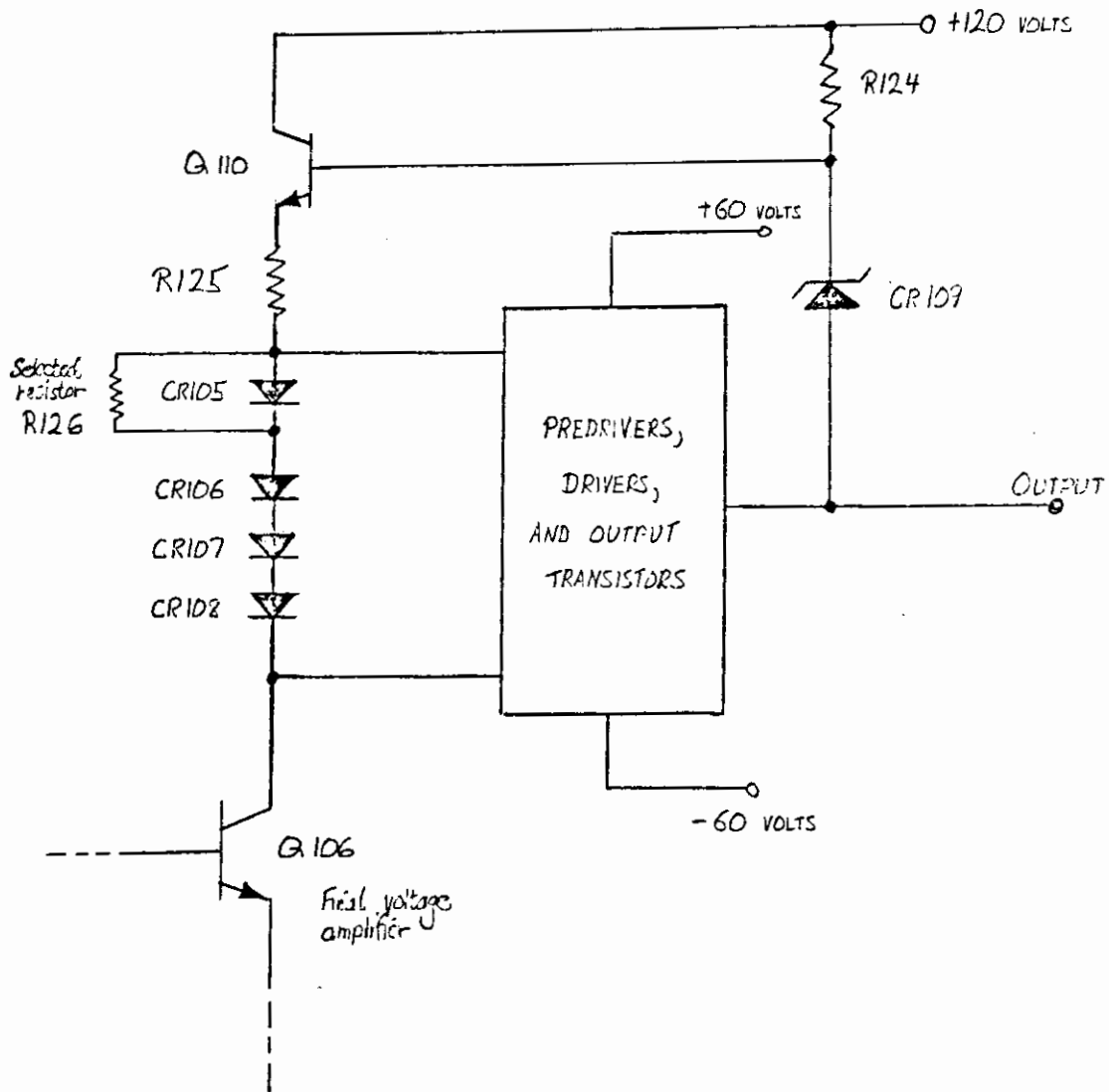

amplifier output. This provides positive feedback which increases the output impedance of Q106 and increases its output driver power, giving it the desired current source characteristics.

Zener CR109 ties to a +120 volt supply in order to insure enough voltage to saturate the output devices when large positive signals are required. If the zener were run to the +60 volt supply, it would drop out of conduction before the output transistors saturated. This would lower the bias current supply and limit the positive output. Using the +120 volt supply, the output transistors saturate first, so the bias supply is adequate for all signals.

Transistor Q110 shares power dissipation with resistor R124. R124 handles the zener current while Q110 supplies the collector current of Q106.

In the final design (see main DC-300 schematic), the best distortion figures resulted from running the zener from the base of the positive output transistors rather than to the output itself. This minor change does not affect the principles of operation outlined above.

Adjustment in bias voltage comes from selected resistor R126. The diode string CR105-CR108 provides a constant bias voltage between the bases of predrivers Q111 and Q104,

keeping them both turned on and ready to go. Precise adjustment of the desired bias level is achieved by selecting the proper value for R126. The predrivers supply the bias for the drivers across R131 and R137 (main schematic) and the bias is measured for adjustment across R132 and R138. The set level across these resistors is 0.325 volts \pm 0.15 volts.

SECTION II: Protection Circuitry

A. Design Objectives

One of the outstanding features of the DC-300 amplifier is its unique protection scheme. The system is designed to relieve instantaneously any dangerous stress on the output devices and then to return the amplifier to normal operation as soon as the stress has been removed. These operations are to be performed automatically in order to lessen inconvenience. A further feature involves protection against overheating due to poor ventilation.

B. Overload Sensing

The basic protection circuitry appears in Figure D-3. Referring to that figure, the resistors $R4$ (c,d,e) are sensing resistors. These resistors, which are very small in value, carry the output current from transistors Q2, Q3, Q5 and Q6. Before the output current becomes dangerously high, the voltage induced across these resistors will turn on the limiting transistors Q112 and Q113, an action which will in turn cut off the drive voltage to predrivers Q111 and Q114. In other words the protection circuitry will simply clamp a limit on the signal whenever it threatens to push the outputs too hard. When the predriver current plus the limiter current equals the current available from the voltage

FIGURE D-3: DG-360 PROTECTION CIRCUITRY (SIMPLIFIED)

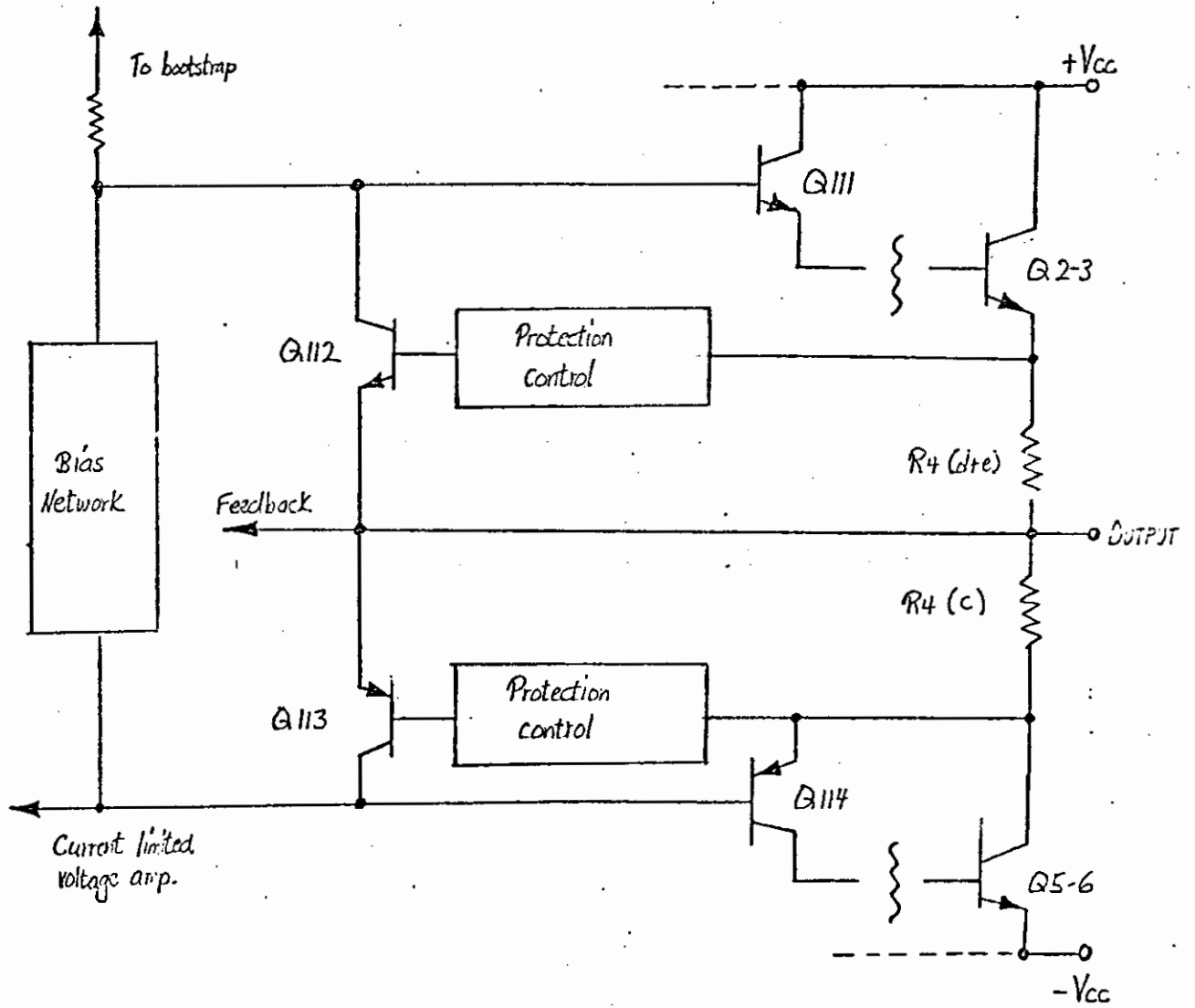

amplifier (Q106) a limit point is reached and the protection mechanism remains there until the overload at the output is removed. This limiting applies itself at the instant an overload occurs and removes itself as soon as the overload disappears.

Efficiency in using output power demands that R_4 be as small as possible (any voltage across R_4 subtracts from the voltage available at the load). This means further that V_{be} of the limiting transistors should be small, so that they will turn on at a relatively low voltage. This leads to the use of germanium transistors for the limiters.

C. Setting Voltage and Current Limits

The description above takes a very simple point of view. In actual operation, the protection circuitry has to handle a wide range of conditions which call for more complicated design. Figure D-4 displays this system in detail, replacing the box labelled "Protection Control" with discrete components.

Notice that on the base of each limiter transistor there is a network of capacitors, diodes, and resistors complicated by a switch. Ignoring the function of the switch for the moment, note that when it is in the position marked "N", the limiter bases are each tied to ground through a diode and a resistor. Look at R_{127} , in the positive limiter (Q112)

FIGURE D-4: PROTECTION CIRCUITRY (DETAILED)

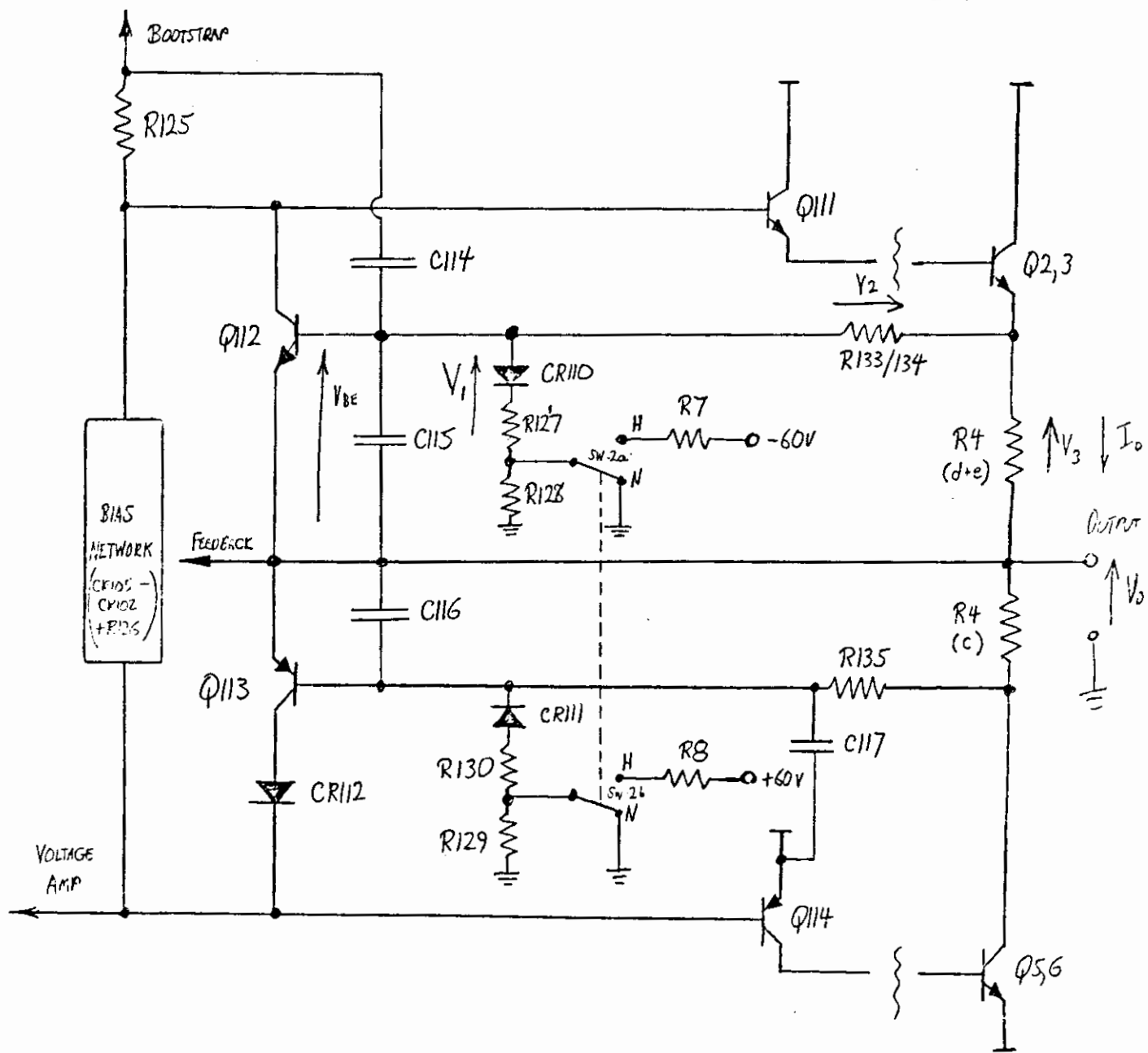

network, to see how this works. As the voltage on the output rises above zero, current flows through R133/134 and R127. Observing the voltages indicates that $V_1 - V_0 = V_{BE}$. When this voltage is greater than forward breakdown on the base-emitter of Q112 (about 0.3 volts on a germanium transistor) at that point Q112 will turn on. The difference in voltage depends on the voltages across R133/134 and R4, since $V_1 + V_2 = V_3 + V_0$, which means that $V_1 - V_0 = V_3 - V_2$. V_3 and V_2 depend, of course, on the current through their respective resistors and these currents in turn arise from the magnitude of the output voltage V_0 and the output current I_0 through R4. The limiter turn-on point varies, then, with the values of the output voltage and current, once the component sizes are established. The components are selected to allow limiter turn-on while the output transistors are still well within their safe operating area. Overall, this circuit increases the available output current (before limiting), as the output voltage increases. The negative limiter circuit operates in the same way, to result in the V-I limiting graph in the DC-300 instruction manual showing output voltage and current limits.

Looking again at the positive limiter, notice that diode CR110 insures that R127 will conduct only when V_0 is positive. Without CR110, a negative value for V_0 would induce current through R127, R113/134 and R4. At sufficient magnitude, this

current would activate the positive limiter while the negative half of the output was carrying the signal, a condition which would be unstable. A similar blocking diode appears in the negative limiter circuit.

D. Hysteresis Mode Operation

Now consider the switch (SW2a/b) that we have been carefully ignoring. N stands for Normal mode, which is the kind of limiting operation just discussed. For some situations requiring a little more operating room, such as might be encountered in driving motors and some speakers, it would be useful, in effect, to de-sensitize the limiters, because the power levels, while high momentarily, are not sustained long enough to damage the amplifier. When the switch is moved to the H (Hysteresis) position, the base of limiter Q112 is tied to the -60 volt supply through CR110, R127 and R7 and to ground through CR110, R127 and R128. The effect of this is to add a negative bias to the positive limiter base (about -0.5 volts). It follows then that the voltage turning on the limiter must overcome this bias as well as the normal junction voltage before the limiter will turn on, which means that higher voltage-current values can be generated at the output without exciting the limiter. In the same way, the negative limiter is biased from the positive supply in the hysteresis mode.

A side effect of the hysteresis mode is the removal of adequate

protection for the output devices for low resistance DC-excited loads.

To regain this protection, the DC supplies are fused with 5 amp fuses. The effects of the hysteresis switch and the DC fuses are illustrated on the V-I limiting diagram found in the DC-300 instruction manual.

Expansion of available output is also supplied by capacitors C115 and C116. These two capacitors slow the response time of the protection circuits to allow short, high-power pulses (which the output transistors can safely handle) to be passed without turning on the limiters. C115/116 also help stabilize the protection circuits. The phase lag in the output which is added by these two capacitors is partially compensated by the addition of C114 on the positive side and C117 on the negative side.

E. Additional Notes

Diode CR112 in the negative limiter circuit, prevents forward biasing of the collector-base junction of Q113. The diode does its job in the following situation: as positive output current increases, the voltage difference between the output and the collector of the negative limiter (Q113) goes to zero and then becomes positive. This happens as the increasing voltage across R4 (d+e) adds to the junction voltages of transistors Q111 and Q1-3 to overcome the voltage across diodes

CR 105-CR108 and leave the collector of Q113 at a voltage more positive than the output. When this difference is large enough (>0.3 volts), it forward biases the collector-base junction of Q113 and prematurely limits the drive to the positive output. Because of the output configuration, a similar diode is not needed for the positive limiter since the problem will not occur at Q112 within the allowable current-limits of the amplifier.

A germanium diode is used for C112 so that the breakdown voltage will not seriously alter the limiting action of Q113.

The other main protection circuitry guards against overheating problems arising from inadequate ventilation. Connected in series with the AC line, a thermal switch is heatsinked between the positive and negative outputs of each channel. At approximately 165° F, the switches will open up and cut off the AC power, thus preventing the transistors from operating outside their safe operating region when the heat derates their power-handling capacity. (see main schematic)

SECTION III: Input Stages and Feedback

A. Design Objectives

The input stages must fulfill a number of important criteria in order to complement the output stages in forming a completely direct-coupled amplifier showing very low distortion and capable of supplying high power. In the discussion following, reference should be made to the main schematic.

To push the distortion level down, a large amount of feedback is required, a condition which demands a large gain-bandwidth. But because of the slow output transistors, the open loop gain of the amplifier must be limited at high frequencies to avoid ringing or overshoot. The limit on high frequency gain enforces a limit on the low frequency gain, since any difference in the gain with frequency causes a phase shift. Keeping the phase shift small means keeping the gain values fairly uniform. Overall, an integrator voltage amplifier does the best job of maximizing feedback for all frequencies. To implement this, several wide-band stages are cascaded.

B. Differential Pair

In order to secure the desired control of input drift and bias currents, a common-emitter differential pair forms the first stage (Q101a/b). Both transistors of the pair

are mounted in a single case to eliminate any temperature differential between the two that could add to the problem of drift.

C. Emitter Follower Stages

For the succeeding stages (Q102, Q109), emitter followers are used to minimize loading on the high impedance input collector loads (R105 and R111, 56K). By keeping this loading down, the response speed of the first stages is kept high. The low impedance output of these stages drives another common emitter pair (Q103-Q108). The emitters of Q103 and Q108 are made current degenerate by the use of resistors R107 and R108. This configuration permits the use of C102 as a bypass capacitor to improve the band-width of these stages by maintaining the high frequency gain.

D. Grounded Base Stages

In order to reduce feedback capacitance in the differential pair Q103-Q108, the signal must be fed into low impedance stages. Q104 and Q107 are therefore grounded base stages, which show very low input impedance.

A further characteristic is the high output impedance of this stage, as seen from the final voltage amplifier. This cuts down hum and noise, as well as high frequency oscillations

which might otherwise be induced on the voltage supply by the output.

E. Final Voltage Amplifier Stage

The final stage of voltage amplification faces a number of conditions for effective operation. A grounded base configuration is used (Q106) because it best meets the requirements for high output impedance (to make the stage look like a current generator, as described in Section I), wide bandwidth and low feedback capacitance. A drawback is the low input impedance of the grounded base design. To overcome this Q105 is added to drive Q106 and present a higher input impedance to the preceding stage(Q104).

A further advantage of this addition is the good linearity resulting from the complementary arrangement of Q105 and Q106.

To lower the power dissipation required of Q105, the collector is returned to the -20 volt supply instead of the positive supply, as this arrangement allows plenty of voltage swing for the performance desired. R112 also limits the dissipation of Q105 by limiting the collector current.

Other components around the final stages perform the following functions:

C103 minimizes feedback capacitance effects, while C121 and C104 are added for stability.

CR101 and CR102 bias Q106. The bias point is chosen to allow adequate voltage swing at the output of Q106. R114 is chosen along with the bias voltage of CR101/102 to set the maximum current desired from this stage.

R113 is on the order of size of the input impedance of Q105. This combination keeps the overall variation in current gain to a minimum.

F. Safety Features

C118, which runs from the output of the final voltage amplifying stage (Q106) to ground, provides a safety factor by controlling the slewing rate of the amplifier. The current required to charge this capacitor limits the high frequency drive to the output stages. Since the stage is current-limited, the capacitor charging speed is limited and the outputs cannot be hit too hard too fast. The current-limiting of this stage is also essential for the output protection devices to work, since the limiter transistors will carry just as much current as Q110 will deliver. Because of the differential arrangement, the input stages are all internally current-limited, a situation which

prevents chain destruction of components in the event that one should short.

G. Feedback Circuitry

The gain-bandwidth of the final voltage amplifier is set by the choice of transistors and bias points. The overall gain of the amplifier is set by feedback resistors R118 and R119. The amount of feedback, as mentioned earlier, is very high. High frequency stabilization is gained by the use of feedback capacitor C101 between the output of Q106 and the collector of input transistor Q101a. A phase advance network (C107, C108, and R117) also ties the feedback line at the base of Q101b to the output of Q106.

At high frequencies, the differential operation of the input disappears and these stages revert to a simple cascade. This is accomplished by the use of C109, which bypasses the collector of feedback stage Q101b at high frequencies.

H. Additional Notes

Stabilization on reactive loads at high frequencies is helped by the RLC network at the output terminals (L1, R5, C5). The RLC network in the emitter of negative predriver Q114 also helps stabilization (R136, L101 C117). The main power supplies are bypassed by C6, C112 and C100 to further insure high frequency stability.

The ± 20 volt supplies for the input stages are zener regulated and bypassed with C111 and C105 to eliminate zener noise.

Potentiometers R103 and R121, with associated resistors, serve to set the input bias current (R103) and to compensate for differences in offset between Q101a and Q101b (R121).

DC 300 Parts List

Schematic Ref.	CROWN Part No.	Description	Notes
CAPACITORS			
C1	1937	80 MFD/100 V Elec	
C2, C3	2797B	13,500 MFD @70 VDC	
C4	2796	10 MFD/150 V Elec	
C5	2938	.1 MFD/200 V Mylar	
C6		5 MFD/70 VDC	
CHOKES AND TRANSFORMERS			
L1	2671A	Power Transformer	
T1	40235	Output Inductor	
CONNECTORS			
J1, J2	1527A	Jack	
J3	2981	MDP Plug Jack	
J4		Plug, 117 VAC Supply	
FUSES			
F1	1905	5A, 3AG, 250 Volt	
F2, F3	2819	5A, 8AG DC	
F1		10A, 3AB AC Line	
POTENTIOMETERS			
R1	2922	100K, Linear Pot Armet	
LAMPS			
I1	2500	NE-2H Neon	
RECTIFIERS AND DIODES			
CR1, CR2, CR3, CR4	40234	Rectifier Assembly	
CR5, CR6, CR7, CR8	2851	IN4003 Diode	
MECHANICAL ASSEMBLIES			
	7721	Power Resistor Mount Clip	
	40245	Left P-C Brkt Ass'y	
	40246	Right P-C Brkt Ass'y	
	40248	Accessory Door (w/fuses)	
	40390	F-P Extrusion	
ACCESSORY HI-FI ADAPTER KIT			
	2957	Fuse, 3AG, 1/4amps	
	2981	MDP Plug	
	3060	3AG Fuse	

Schematic Ref.	CROWN Part No.	Description	Notes
RESISTORS			
R2	2857	2.7 ohm 1/2 watt	
R3	1076	1.5K 1/2 watt	
R4	2766	Power Resistor 0.2 ohm	
R5	1001	2.7 ohm lw resistor	
R6	1056	27K 1/2 watt resistor	
R7, R8	2807	4.7 1 watt resistor	
SWITCH			
SW1	2835	SPST Power Switch	
SW2	3247	DPDT Slide Switch	
SW3, SW4	2799	Thermal Switch	
TRANSISTORS			
Q2, Q3, Q5, Q6	2841	SDT-7698 Solitron (Output matched)	
Q1, Q4	2841A	2N3773 Silicon Transistor (Output matched)	
Q1, Q4	2895	MHT 7698 Transistor	
Q2, Q3, Q5, Q6	2964	RCA Output (matched)	
Q2, Q3, Q5, Q6	3176	Westinghouse Transistor (matched)	
MECHANICAL PARTS			
	1221	HMB Fuse Holder for DC Line	
	1306	Shoulder Washer	
	1577	Knob	
	1646	Flat Fiber Washer	
	1655	6-32 x 1/4 Binding Hd Screw	
	1954	Captive Nut	
	2018	6-32 Captive Nut	
	2019	Bright Nut 3/8	
	2046	6-32 x 1/2 Socket Cap Screw	
	2109	8-32 x 1/4 Flat Head screw	
	2136	Bright Washer 3/8	
	2189	Black Toggle Cap	
	2346	Red Lens & Clip	
	2359	Strain Relief	
	2803	Dual Binding Post	
	2823A	3 Wire Line Coard	
	2824A	Heat Sink Extrusion	
	2826	Side Cover	
	3075	Cover, Back	
	3235	Output Jack cover	
	3252	DC300 Chassis	
	P7680B	Fuse Mount Chassis	
	P7691A	Front Panel	
	7682		

DC-300 Main Board Parts List

Quan.	Schematic Ref.	Description	CPN	Price	Quan.	Schematic Ref.	Description	CPN	Price
<u>RESISTORS</u>									
2	R131, R137	180 Ohm 1/2 W.	1006	.12	2	C104, C109	.01 Disc	1751	.28
1	R136	100 Ohm 1/2 W.	1007	.12	1	C101	27 pf	2342	.21
1	R114	56 Ohm 1/2 W.	1009	.12	1	C108	5 pf	2820	.44
1	R122	100 K 1/2 W.	1027	.12	1	C107	10 pf	2821	.44
1	R116	10 K 1/2 W.	1035	.12	1	C113	3.9 pf Ceramic Cap	2937	.18
1	R109	5.6 K 1/2 W.	1042	.12	1	C110	.1 mfd 200 V. Fil.	2938	.33
1	R112	3.3 K 1/2 W.	1051	.12	1	C103	.047/200	2977	.18
1	R125	3.9 K 1/2 W.	1059	.12	2	C119, C120	.1 ceramic disc	2600	.15
2	R133, R134	240 Ohm 1/2 W. 5%	1069	.12					
1	R113	1.5 K 1/2 W.	1076	.12					
1	R124	68 K 1/2 W.	1612	.12					
2	R128, R129	4.7 K 1/2 W.	1640	.12					
1	R118	10 K 1/2 W. (1%)	2343	.65	2	CR105, CR112	IN270 Diode	2437A	.19
2	R132, R138	5.6 Ohm 1 W. 5%	2355	.20	3	Q106, Q110, Q111	40327 Transistor	2643	2.02
1	R126	Value Selected			1	Q112	2N1304 Transistor	2721	.97
1	R117	470 Ohm 1/4 W.	2626	.12	1	CR106	MR2360 Diode	2798	.42
1	R101	1 K 1/4 W.	2627	.12	2	CR110, CR111	IN4148 Diode	3181	.16
2	R107, R108	2.2 K 1/4 W.	2628	.12	1	Q113	2N1305 Transistor	2817	.85
2	R106, R110	3.9 K 1/4 W.	2630	.12	1	Q101 (A&B)	TD 101 Transistor	2832	3.11
1	R102	10 K 1/4 W.	2631	.12	1	Q114	SS7304 Transistor	2923	5.95
1	R135 (was 5%)	120 Ohm 1/2 W. 1%	2804	.35	3	Q102, Q105, Q109	2N3859A Special	2961	.52
1	R104	1 M 1/2 W.	2805	.12	4	Q103, 104, 107, 108	Transistor	2982	1.00
1	R123	3.3 K 1 W.	2806	.44	2	CR101 & 2, CR107 & 8	MZ2361 Diode	3039	.95
2	R127, R130	5.1 K 1 W. 5%	2808	.44	3	CR103, CR104, CR109	IN968B Zener	3277	.48
2	R105, R111	56 K 1/2 W. Film	2810	.36					
1	R119	187K 1/2 W. (1%)	2822	1.14					
1	R115 (was 39K)	43 K 1/2 W. Film	2944	.36					
1	R120 (was 10 meg)	8.2 M 1/2 W.	2984	.12					
1	R139	18 Ohm 1/4 W.	3057	.12					
<u>CAPACITORS</u>									
1	C117	.0047 Pacer	1104	.33	6		Transistor Pads	1250	.10
1	C102	47 pf	1114A	.18	2		PC comp. Recp.	1655	.20
1	C118	200 pf	1118B	.21	1	R121	100 K Horz. Pot	1709	.51
2	C106, C112	5/70	1678A	.35	1	R103	1 K Horz. Pot	1711	.27
1	C114	.0015 Pacer	3089	.13	1	L101	1 mhy Inductor	2441	.39
2	C105, C111	1/30 Tantalum	1750A	.42	1		NF207 Heat Sink	3175	.30
							Main Board (assy)	41033	156.50
							(Must specify amp s/n)		
							City of Springfield	40240	

SUPPLEMENTAL DC-300 PARTS
REPLACEMENT KIT
(Listing parts not included in DC-300A kit)

Designed to supply parts needed for 5-10 repair jobs.

PART DESCRIPTION	CPN	QTY	W-S-S	TOTAL PRICE
Transistor:				
Trans. Solitron MHT7698	2895	2	6.75	13.50
Trans. RCA 61061	3348	3	1.30	3.90
" 2N1304	2721	4	.55	2.20
" 2N1305	2817	4	.47	1.88
" TD101 Differential	2832	2	1.74	3.48
Diodes:				
MZ2361	3039	4	.53	2.12
1N968B Zener	3277	6	.27	1.62
Capacitors: 5mfd - 70vdc	1678	10	.20	2.00
Neon Bulbs: 1NE2H	2500	5	.131	.65
Fuses: 5amp/fast acting	1905	25	.07	1.75
Canoe clips	1726	2	.02	.04
Captive nuts:				
6/32	2019	2	.02	.04
8/32	2018	2	.02	.04
10/32	1334	2	.07	.14

Also Recommended: Aerosol Coolant -- for temperature checking components

Heat Sink compound (such as Dow-Corning 340) for replacing
output transistors.

A-7. FUSE CHASSIS

120 VOLT
SUPPLY BOARD

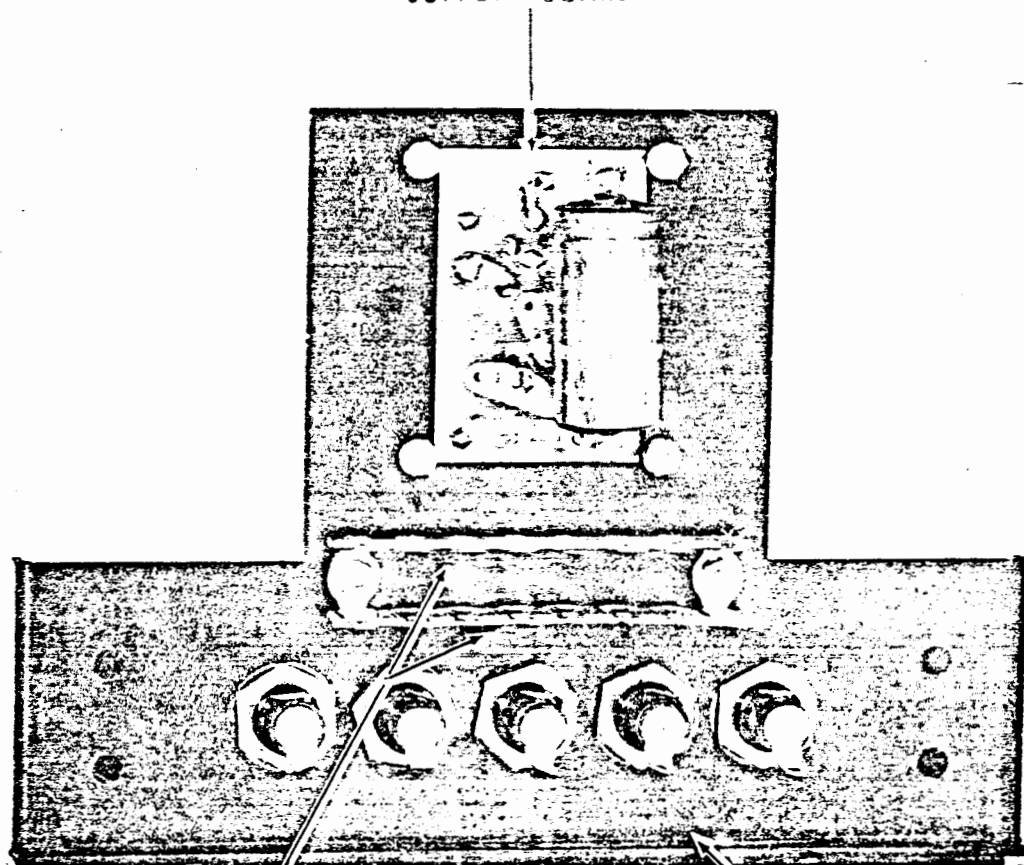

TERMINAL STRIPS FOR
TRANSFORMER PRIMARY WIRING

AC AND DC
FUSE HOLDERS

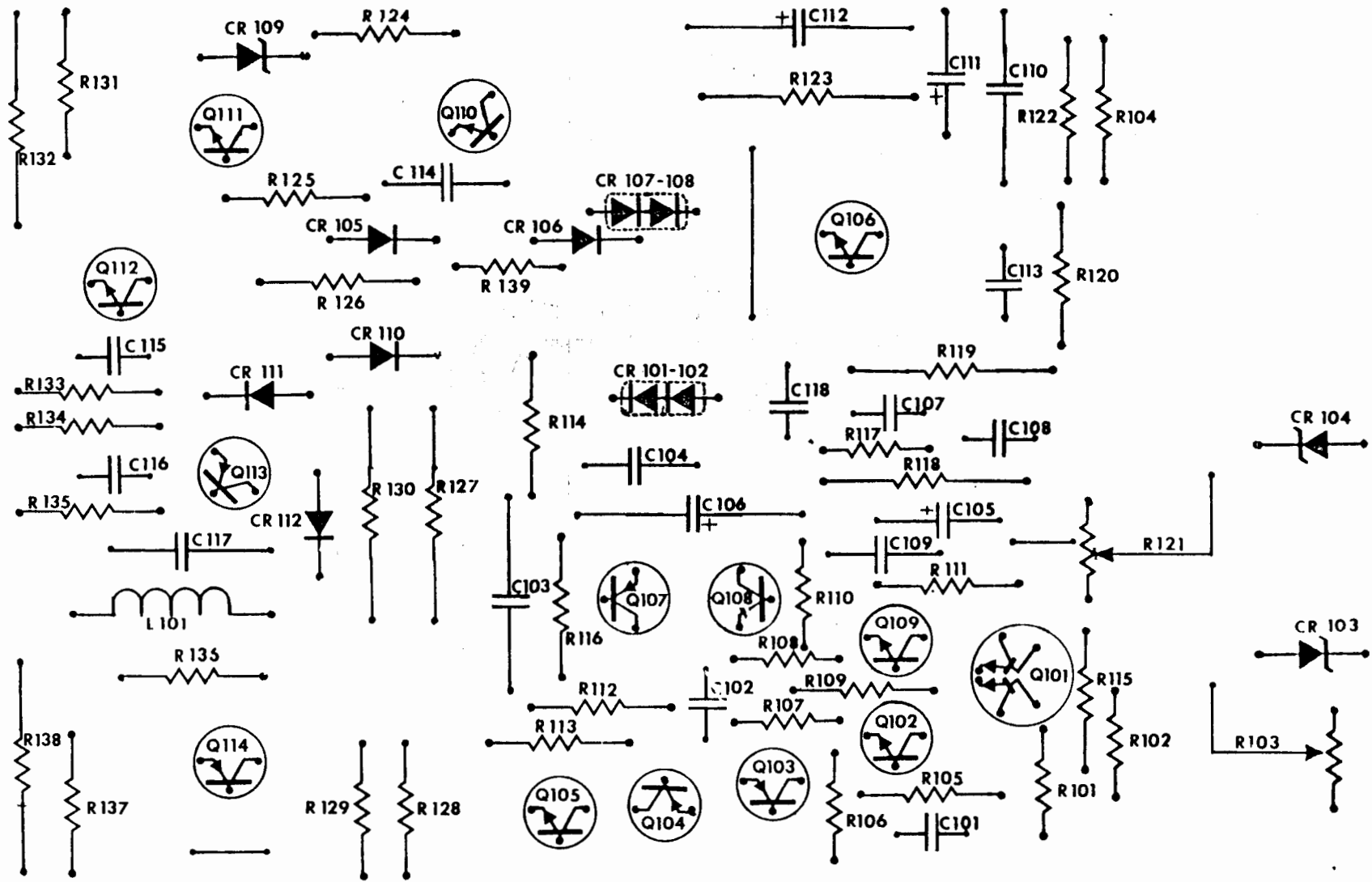

SCHEMATIC NOTES

1. This schematic revision applies to amplifiers numbered A2000 and above (some parts are different on earlier schematics).
2. DC voltages are shown for various points. These are the normal, operating voltages for zero input signal. The following notes also apply:
 - a. Voltage across C102 (47pf-input stages) should measure 1 volt or less. In other words the emitter potentials for Q103 and Q108 will be within one volt of each other if the input stages are balanced properly.
 - b. The voltage on the emitter of Q103 should be within 0.1 volt of the base voltage of Q102. The opposite ends of these two junctions are tied together, and since both are normally conducting, both should normally show the same 0.6 volt drop. The same situation exists with Q108-Q109.
 - c. In recent units the zener voltages should be within 5% of the value shown (within 1 volt of 20 volts). Older amplifiers may have 18 volt zeners with 10% tolerance.
3. The heavy continuous trace follows the primary signal path through the circuit. The heavy broken trace shows feedback paths.
4. Wire color codes are given for the main power supply and for the chassis-to-board wiring.
5. Components enclosed in dotted lines on the schematic are physically enclosed in a single case.

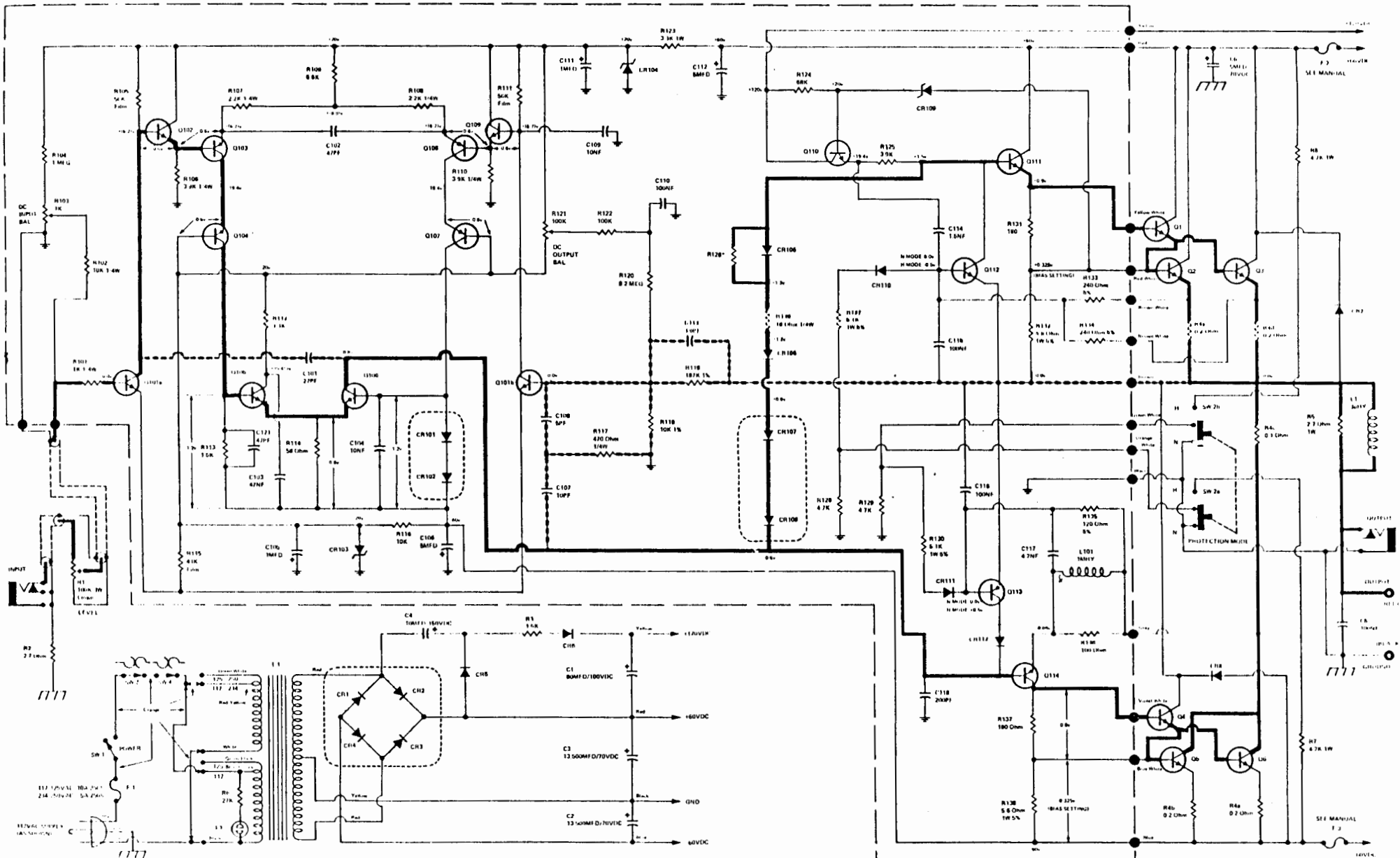

Crown DC 300 LAB STANDARD POWER AMPLIFIER

MI 230A

*SELECTED
 ALL RESISTORS 1/2 WATT 10% UNLESS OTHERWISE SPECIFIED
 LIST R101-R101 CR102-UT14

A-II. TEST EQUIPMENT - DC-300 SERVICE

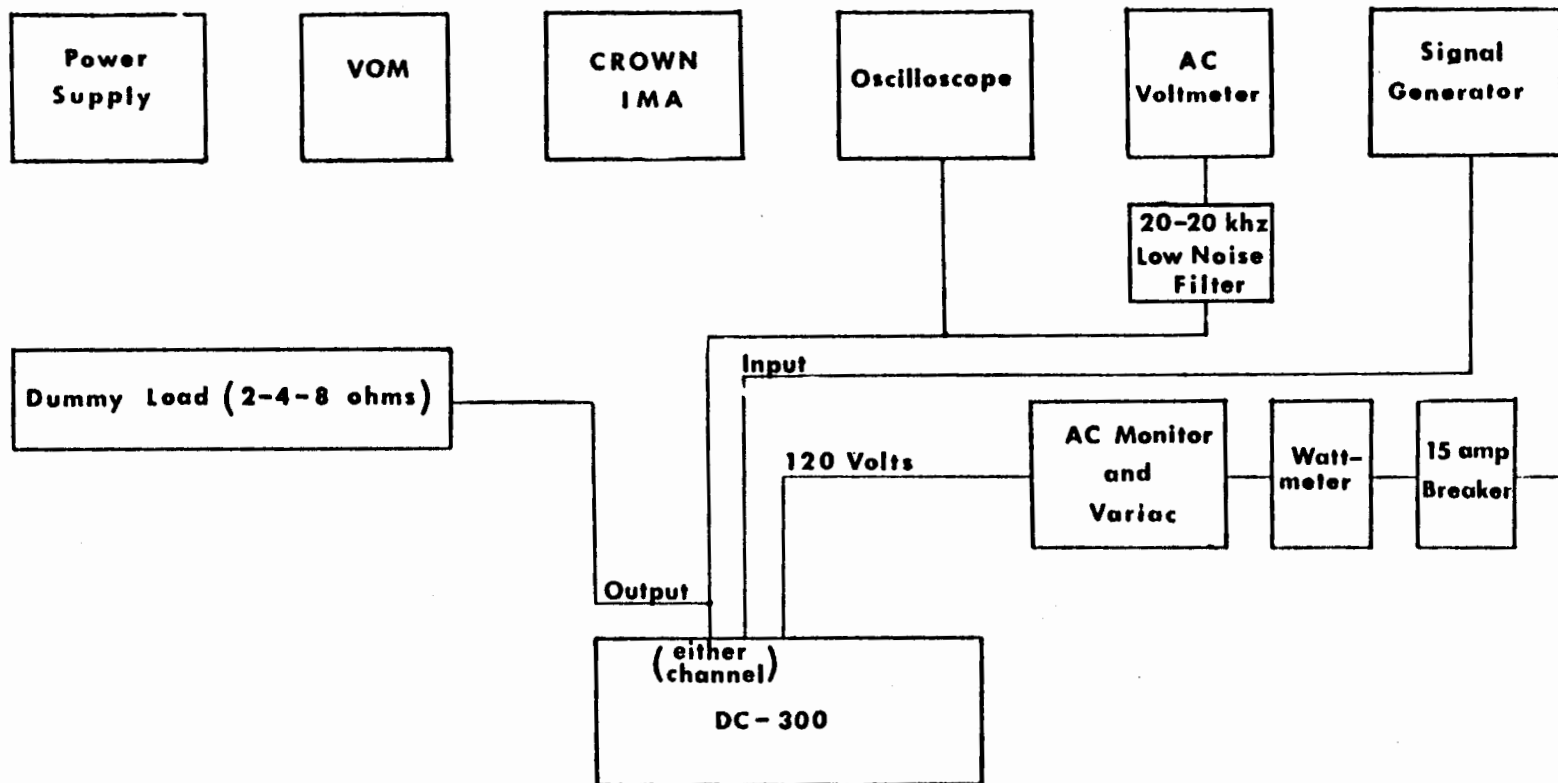

A-12. TYPICAL CHECKOUT RESULTS

DC-300

Serial Number A XXX

	Ch.-1	Ch.-2
1 K Hz. Cont. Power 8 Ohm	<u>190</u> Wrms.	<u>190</u> Wrms.
1 K Hz. 300W Cont. 4 Ohm	<u>OK</u>	<u>OK</u>
Prot. Normal	<u>OK</u>	<u>OK</u>
Prot. Hysteresis	<u>OK</u>	<u>OK</u>
20 K Hz. Cont. Power 8 Ohm	<u>185</u> Wrms.	<u>185</u> Wrms.
10 K Hz. Sq. Wave IM Dist. 8 Ohm (60-7K Hz. 4:1)	<u>OK</u>	<u>OK</u>
	<u>018</u> % 150 W	<u>020</u> % 150 W
	<u>008</u> % 47.5 W	<u>010</u> % 47.5 W
	<u>004</u> % 15 W	<u>003</u> % 15 W
	<u>004</u> % 4.75 W	<u>004</u> % 4.75 W
	<u>006</u> % 1.5 W	<u>005</u> % 1.5 W
	<u>009</u> % 475MW	<u>008</u> % 475MW
	<u>016</u> % 150MW	<u>012</u> % 150MW
	<u>034</u> % 47.5MW	<u>025</u> % 47.5MW
	<u>024</u> % 15MW	<u>020</u> % 15MW
Hum and Noise (20Hz - 20KHz)	<u>115</u> DB below 150W 8 Ohm	<u>115</u> DB below 150W 8 Oh
Quies. AC Power Input	<u>25</u> W at 120 VAC	

SCHEMATIC NOTES

1. This schematic revision applies to amplifiers numbered A2000 and above (some parts are different on earlier schematics).
2. DC voltages are shown for various points. These are the normal, operating voltages for zero input signal. The following notes also apply:
 - a. Voltage across C102 (47pf-input stages) should measure 1 volt or less. In other words the emitter potentials for Q103 and Q108 will be within one volt of each other if the input stages are balanced properly.
 - b. The voltage on the emitter of Q103 should be within 0.1 volt of the base voltage of Q102. The opposite ends of these two junctions are tied together, and since both are normally conducting, both should normally show the same 0.6 volt drop. The same situation exists with Q108-Q109.
 - c. In recent units the zener voltages should be within 5% of the value shown (within 1 volt of 20 volts). Older amplifiers may have 18 volt zeners with 10% tolerance.
3. The heavy continuous trace follows the primary signal path through the circuit. The heavy broken trace shows feedback paths.
4. Wire color codes are given for the main power supply and for the chassis-to-board wiring.
5. Components enclosed in dotted lines on the schematic are physically enclosed in a single case.