

ONKYO SERVICE MANUAL

INTEGRATED STEREO AMPLIFIER Model A-10

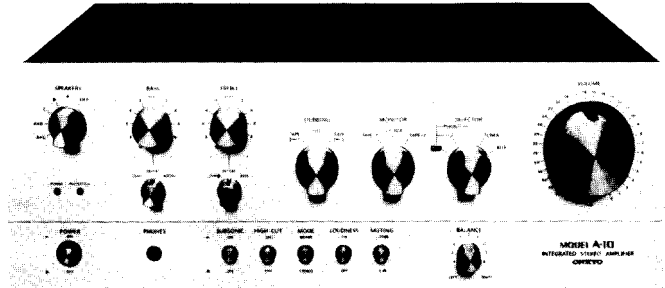

SPECIFICATIONS

Power Amplifier Stage		Total Harmonic Distortion	0.05% at rated output
Power Output	85 watts per channel, min. RMS both channels driven at 8 ohms from 20Hz to 20kHz, with no more than 0.08% total harmonic distortion. 130 watts perchannel, min. RMS, at 4 ohms both channels driven, at 1kHz, 0.08% total harmonic distortion. 90 watts per channel, min. RMS, at 8 ohm both channels driven, at 1kHz, 0.08% total harmonic distortion.	IM Distortion (70Hz:7kHz = 4:1)	0.08% at rated output
Total Harmonic Distortion (AUX)	0.08% at rated power output	Frequency Response	PHONO MM: ± 0.2 dB at 30 – 15,000Hz AUX: +0, –1dB at 10 – 50,000Hz
IM Distortion (AUX) (70Hz:7kHz = 4:1)	0.1% at rated power output	Phono Overload	230mV RMS at 1kHz, 0.1% THD
Frequency Response	2 – 80,000 Hz (± 1 dB)	Signal to Noise Ratio	PHONO MC: 68 dB (IHF A network) PHONO MM: 78 dB (IHF A network) AUX: 90 dB (IHF A network)
Square Wave Response (Tilt)	better than 5% at 50Hz	Output Voltage	PRE OUT: 1.5 V REC OUT: 150 mV
Signal to Noise Ratio	110 dB (IHF A network)	Output Impedance	PRE OUT: 2.7 kohms REC OUT: 2.5 kohms (PHONO)
Damping Factor	50 at 8 ohms	Tone Controls BASS	± 10 dB at 100Hz
Rated Input	1.5 volts	Tone Controls TREBLE	± 10 dB at 10kHz
Input Impedance	50 kohms	Turnover Frequencies	BASS: 125Hz, 400Hz TREBLE: 2kHz, 8kHz
Load Impedance	4 to 16 ohms	Filters	SUBSONIC: 10Hz (12dB/oct.) HIGH CUT: 6kHz (12dB/oct.)
Preamplifier Stage		Muting	–20 dB
Input Sensitivity and Impedance	PHONO MC: 100 μ V, 20 ohms PHONO 1 & 2: 2.5mV, 50 kohms TUNER: 150mV, 50 kohms AUX: 150mV, 50 kohms TAPE PLAY 1 & 2: 150mV, 50 kohms	Loudness (–40 dB)	+5 dB at 100 Hz +5 dB at 10 kHz
		General	
		Power Supply	AC 120V, 60Hz or AC 220V, 50Hz
		Dimensions	17½"(W)x6¼"(H)x15-13/16"(D) 444(W)x159(H)x401(D)mm
		Weight	39.6 lbs. 18kg.
		Semiconductors	65 transistors, 26 diodes

Specifications and features are subject to change without notice.

ONKYO
AUDIO COMPONENTS

CIRCUIT DESCRIPTION

1. SPEAKER PROTECTION CIRCUIT

The speaker protection circuit is operated:

- 1) When the B circuit is unstable when the power is turned ON (approximately 5 seconds).
- 2) When the speaker terminals are shorted and abnormal current has flowed in the power amplifier thru this low impedance.
- 3) When the center voltage has increased because of trouble at the differential amplifier, etc.
- 4) When the temperature of the heat sink has risen.

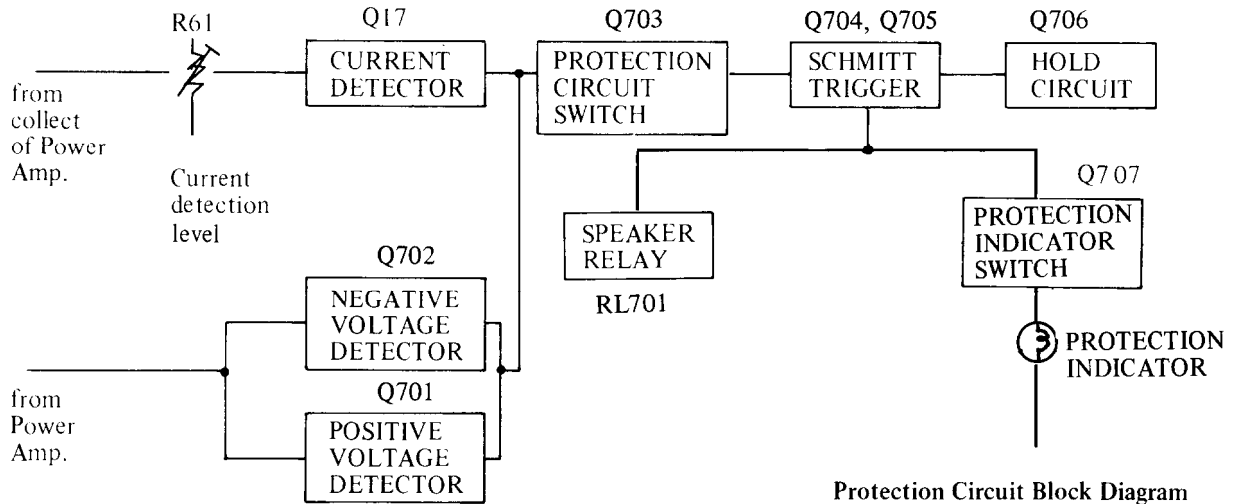

When Q703 is turned on by voltage detection or current detection, Q704 is turned ON by the voltage drop across R709. Q704, Q705 constitute a digitalized, fast response Schmitt trigger circuit. When Q704 is turned ON, Q705 is turned OFF. Q705 is a relay drive transistor. When it is turned OFF, the relay is also turned OFF.

When the power switch is turned ON, charging current flows thru the loop R710 → C703 → R708 → R709 and Q704 is turned ON by the voltage drop across R709. Consequently, Q705 and the relay are turned OFF until the charging current drops below a certain value. When the power switch is turned OFF, the B voltage falls and C703 is quickly discharged thru the loop C703 → R710 → D701. During normal operation, C703 is charged to almost the B voltage. But since the saturation resistance of Q703 is sufficiently low, when Q703 is turned ON, C704 is quickly discharged thru the loop C703 → R710 → Q703 and the relay is also turned OFF. The relay is not turned ON again thereafter until C703 is charged, even if the set should return to normal and Q703 is turned OFF.

HOLD CIRCUIT

The reference voltage is produced by R716, R717, Q706 is operated as a comparator. When Q705 has been turned OFF, the collector voltage of Q705 rises and C706 is charged. Therefore, when C706 is charged to above a certain voltage relative to the reference voltage at the junction of R716 and R717, Q706 is turned ON, Q703 is turned ON thru R728 and the circuit is held.

CURRENT DETECTOR

Q17 is turned ON by the voltage detected from the collector circuit of the power amplifier. C24 prevents erroneous operation, R61 sets the current detection level and thermister R66 controls changes in the current detection level caused by temperature rise.

When the impedance is low at a certain frequency of the speaker, the protection circuit may be unexpectedly actuated each time a large audio signal of that frequency has entered. However, when this occurs the relay is opened and the power amplifier current returns to normal. The power amplifier current is also automatically returned to normal in a like manner when the load has been inadvertently shorted momentarily.

When connected with the load shorted, the relay is repeatedly turned ON and OFF in load short → relay OFF (no load) → automatic reset (load short current detection) → relay OFF order. Since the OFF time is sufficiently longer than the relay ON time in this case, the voltage across C705 gradually increases until a voltage sufficient to turn Q706 is reached, at which time the relay is held OFF, thus protecting the power transistor against damage by a continuous overcurrent.

VOLTAGE DETECTOR

The voltage detection circuit is an OR circuit consisting of Q701, Q702. First, the Lch and Rch signals are mixed by R701, R702. When this voltage is minus, Q702 is turned ON and when this voltage is plus, Q701 is turned ON and the relay is turned OFF.

Since the center voltage is unrelated to ON-OFF of the load, when an abnormal voltage has been detected, the relay remains off and the hold circuit is operated until the voltage returns to normal. Once the hold circuit has been actuated it is not reset until the power has been turned back on after the cause of the trouble has been corrected.

EXPLODED VIEW

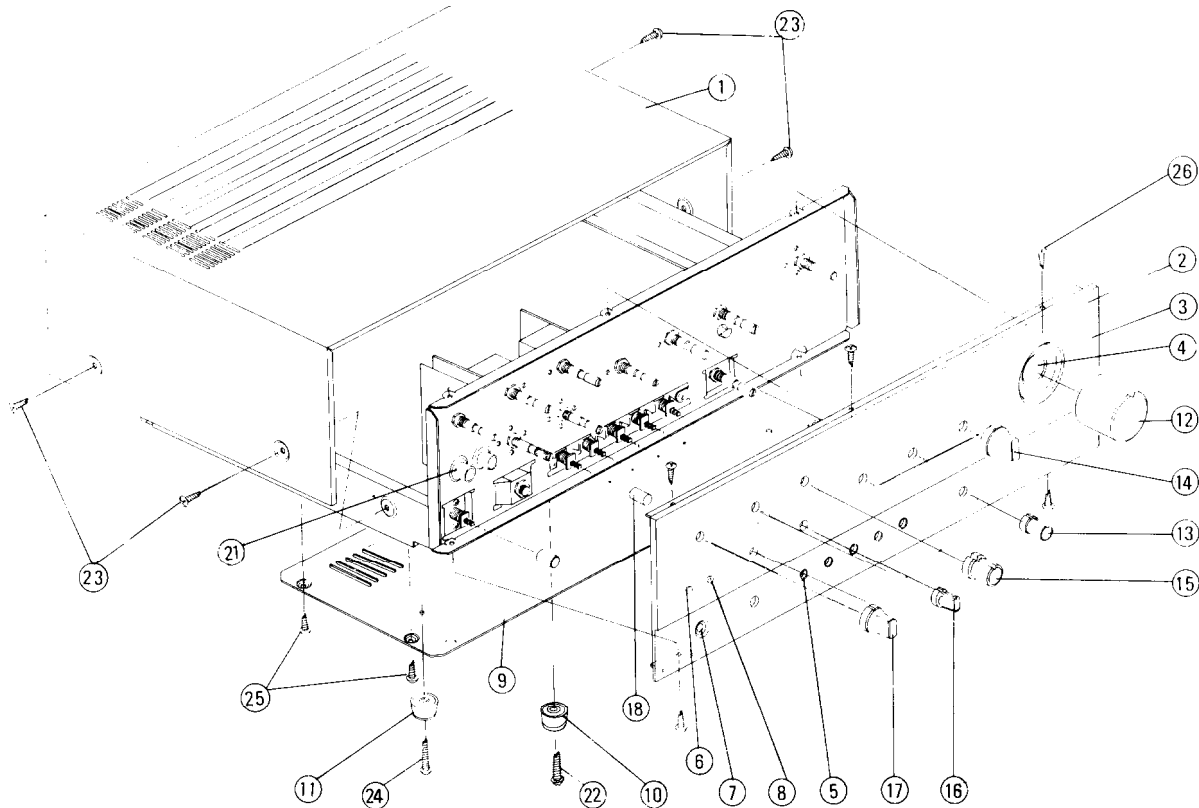

PARTS LIST

REF. NO.	CIRCUIT NO.	PARTS NO.	DESCRIPTION	REF. NO.	CIRCUIT NO.	PARTS NO.	DESCRIPTION
1	A351	28184032	Amp. top cover	15	A806	28320161	Tone control knob
2		12819121	Front panel ass'y	16	A807	28320163	Tone shift knob
3	A501	27210083	Front panel	17	A808	28320162	Speaker selector knob
4	A502	27265009A	Ring	18	A805	28320160	Push switch knob
5	A504	27267014	Guide for push switch knob	19	A804	28320159	Power switch knob
6	A505	27267015	Guide for power switch knob	20	P801	250126	3P64M, stereo headphone jack
7	A506	28198502	Facet for power indicator	21		28140024	Cushion
8	A507	28198509	Facet for protection indicator	22	A604	834140162	4STS+16BQ
9	A601	27170036	Bottom board	23	A352	838440109	4TTB+10C BC, Screw
10	A602	27175004	Leg	24	A605	832140122	4STR+12BQ
11	A603	280379	Leg	25	A600	831130082	3STW+8BQ
12	A801	28320155	Volume control knob	26	A509	838130062	3STB+6BQ
13	A802	28320157	Balance control knob				
14	A803	28320158	Selector, Tape monitor/ Dubbing knob				

COMPONENT LOCATION

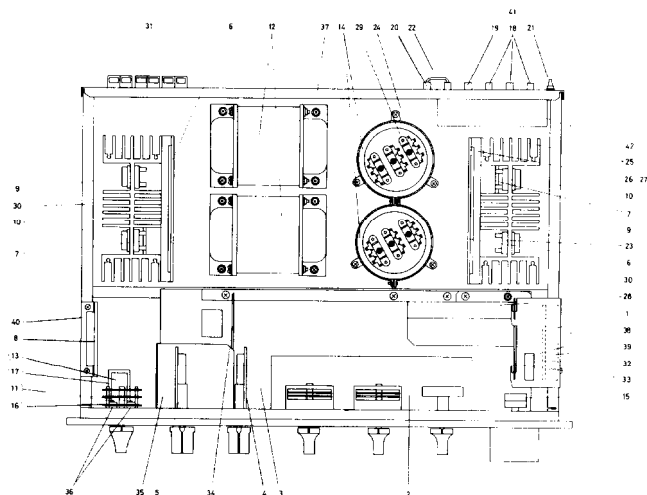

U.S.A. Model

REF. NO.	CIRCUIT NO.	PARTS NO.	DESCRIPTION
1	U1	12819535	NAAF-435, Head amp. p.c.b.
2	U2	12819534	NATM-434, Tape monitor p.c.b.
3	U3	12819536	NAAF-436, Preamp. p.c.b.
4	U4-1	12819574A	NATS-374a Part-1, Treble control p.c.b.
5	U4-2	12819574A	NATS-374a Part-2, Bass control p.c.b.
6	U5, U7	12819505A	NADA-405a, Power amp. p.c.b.
7	U6, U8	13759506	NACC-406, Bias stabilization p.c.b.
8	U9	12819537	NAPS-437, Rectifier p.c.b.
9	Q12, Q14	2200762 2200763 ^{OR}	2SD675(B) or 2SD675(C), Power amp. transistor
10	Q13, Q15	2200772 ^{OR} 2200773 ^{OR}	2SB665(B) or 2SB665(C), Power amp. transistor
11	PL001 PL701	210015A	6.3V 50mA, Power/protection indicator Light
12	T901,T902	230213	NPT-630D, Power transformer
13	C901,C902	3504012	0.01μF 125V, UL capacitor
14	C911, 913	3504103	13,000μFx2 63V, Elect. capacitor
15	R313	5104041	N35DGR32C100KT30M, Volume control variable resistor
16	S801	25030094	NRS-226-30YW, Speaker selector switch
17	S901	25035061	NPS-121-L26P, Power switch
18	P802~ P804	250170	NTM-2WPBL-E1, Phono input terminals
19	P805	25045025	NPJ-4PRBL03, Tuner/Aux. input terminals
20	P807	25045029	NPJ-6PRBL07, Tape/Pre output and main input terminals
21	P809	25060008	Ground terminal
22	P810	25055015	Pre/main connection bar
23	Q501a-Q504a Q601a-Q604a	250249	M-1614, Power amp. transistor socket
24	A001	27100027	Chassis
25	A002	27160025	Radiator
26	A003	27140151	Bracket U for power amp. p.c.b.
27	A004	27140152	Bracket D for power amp. p.c.b.
28	A006	27150055	Shielded plate B.
29	A016	25060025	7P terminal
30	A021	27115026A	Side bracket
31	P808	25060005	NTM-12PUR1, Speaker terminal
32	A026	27150074A	Shielded plate F
33	A025	27150073A	Shielded plate E
34		27150049	Shielded plate
35	A032	27150048	Shielded plate
36	A033	270611	Cover for PL001/PL701
37	A041	27120093A	Back panel
38	A005	28140051	Cushion
39	A023	27140166	Bracket for rectifier p.c.b.
40	A022	27140164	Bracket for head amp. p.c.b.
41	P806	25045022	NPJ-6PRBL01, Tape input/ output terminals
42	A024	27225023	Shielded case A
	P901	25050015	NSCT-6P01, AC outlet
	F901	252052	7A ST-6, AC fuse
	F901a	250080	S-N1301, Fuseholder for F901
	W901	253091	AS-UC-2, Power Supply Cord
	W901a	270280	SR-4K-4, Strainrelief

220V model

REF. NO.	CIRCUIT NO.	PARTS NO.	DESCRIPTION
1	U1	12819535	NAAF-435, Head amp. p.c.b.
2	U2	12819534	NATM-434, Tape monitor p.c.b.
3	U3	12819536	NAAF-436, Preamp. p.c.b.
4	U4-1	12819574A	NATS-374a Part-1, Treble control p.c.b.
5	U4-2	12819574A	NATS-374a Part-2, Bass control p.c.b.
6	U5, U7	12819505A	NADA-405a, Power amp. p.c.b.
7	U6, U8	13759506	NACC-406, Bias stabilization p.c.b.
8	U9	12819537	NAPS-437, Rectifier p.c.b.
9	Q12, Q14	2200762 2200763 ^{OR}	2SD675(B) or 2SD675(C), Power amp. transistor
10	Q13, Q15	2200772 ^{OR} 2200773 ^{OR}	2SB665(B) or 2SB665(C), Power amp. transistor
11	PL001, PL702	210015A	6.3V 50mA, Power/Protection indicator light
12	T901,T902	230214	NPT-630G, Power transformer
13	C901,C902	3500052	PME271Y510CEE, IS capacitor
14	C911,C913	3504103	13,000μFx2 63V, Elect. capacitor
15	R313	5104041	N35DGR32C100KT30M, Volume control variable resistor
16	S801	25030094	NRS-226-30YW, Speaker selector switch
17	S901	25035051	NPS-121-L16P, Power switch
18	P802~ 804 P804	250170	NTM-2WPBL-E1, Phono input terminals
19	P805	25045025	NPJ-4PRBL01, Tuner/Aux. input terminals
20	P807	25045029	NPJ-6PRBL07, Tape/Pre output and main input terminals
21	P809	25060008	Ground terminal
22	P810	25055015	Pre/main connection bar
23	Q501a-Q504a Q601a-Q604a	250249	M-1614, Power amp. transistor socket
24	A001	27100027	Chassis
25	A002	27160025	Radiator
26	A003	27140151	Bracket U for main amp. p.c.b.
27	A004	27140152	Bracket D for main amp. p.c.b.
28	A006	27150055	Shielded plate B
29	A016	25060025	7P terminal
30	A021	27115026A	Side bracket
31	P808	25060005	NTM-12PUR1, Speaker terminal
32	A026	27150074A	Shielded plate F
33	A025	27150073A	Shielded plate E
34		27150049	Shielded plate
35	A032	27150048	Shielded plate
36	A033	270611	Cover for PL001/PL701
37	A041	27120094A	Back panel
38	A005	28140051	Cushion
39	A023	27140166	Bracket for rectifier p.c.b.
40	A022	27140164	Bracket for head amp. p.c.b.
41	A806	25045022	NPJ-6PRBL01, Tape input/ output terminals
42	A024	27225023	Shielded case A
	F901	252014	4A-T, AC fuse
	F901a	250100	S-N2052 Fuseholder for F901
	W901	253088	AS-VDE-1, Power Supply Cord

EQUALIZER, PREAMPLIFIER, PROTECTOR PC BOARD (NAAF-436)—PARTS LIST

CIRCUIT NO.	PARTS NO.	DESCRIPTION	CIRCUIT NO.	PART NO.	DESCRIPTION
TRANSISTORS			DIODES		
Q251~Q254	2210665	2SA841(GR) Differential amp.	D251~D254		
Q255, Q256	2210666 or	2SA841(BL) Equalizer amp.	D701~D703	223105	1S1555
Q257, Q258	2210675	2SC1681(GR)	D705, D706		
	2210676 or	2SC1681(BL) or Equalizer amp.	D704	223802	1S1885
Q259, Q260	2211042	2SC1318(Q)	D909~912		
	2211043 or	2SC1318(R) or Equalizer amp.	D913, D914	224018	WZ-250, Zener
Q261, Q262	2211052	2SA720(Q)			
	2211053	2SA720(R) or Equalizer amp.			
Q301~Q304	2210665,	2SA841(GR),	C251, C252	390480227	2.2 μ F 50V, LD
	2210666,	2SA841(BL),	C253, C254	352754701	47 μ F 25V, Elect.
	2210416 or	2SA726(F) or	C261, C262	390883317	330 μ F 50V, SLD
	2210417	2SA726(G) or	C263, C264	374124724	4700pF \pm 5% 50V, DE
Q305~Q308	2210675	2SC1681(GR) or Preamp.	C265, C266	374125624	5600pF \pm 5% 50V, DE
	2210676 or	2SC1681(BL) or Preamp.	C267~C270	374121534	0.015 μ F \pm 5% 50V, DE
Q701, Q702	2211183	2SC1740(R) or Protection	C275, C276	390980107	1 μ F 50V, LM
Q704, Q706	2211184 or	2SC1740(S) or Protection	C283, C285	352764711	470 μ F 35V, Elect.
Q703	2210416 or	2SA726(F) or Protection	C305, C306	390480227	2.2 μ F 50V, LD
	2210417	2SA726(G) or Protection	C311, C312	352754701	47 μ F 25V, Elect.
Q705	2210863	2SC1212AWT(C) or Protection	C317, C318	352722211	220 μ F 6.3V, Elect.
	2210864 or	2SC1212AWT(D) or Protection	C319, C320	390980107	1 μ F 50V, LM
Q707	2211184	2SC1740(S), Protection	C321, C322	390480227	2.2 μ F 50V, LD
Q901	2200663 or	2SC1626(O) or Rectifier	C329, C330	372328214	820pF \pm 5% 50V, ST
	2200664	2SC1626(Y) or Rectifier	C331, C332	392684791	0.47 μ F 50V, LR
Q902	2200673 or	2SA816(O) or Rectifier	C333, C334	352780101	1 μ F 50V, Elect.
	2200674	2SA816(Y) or Rectifier	C337, C339	352762211	220 μ F 35V, Elect.
			C702	352724711	470 μ F 6.3V, Elect.
					CAPACITORS

CIRCUIT NO.	PART NO.	DESCRIPTION	CIRCUIT NO.	PART NO.	DESCRIPTION
C703	352753301	33 μ F 25V, Elect.			GROUND PLATE
C704	352780331	3.3 μ F 50V, Elect.			
C705	352741011	100 μ F 16V, Elect.		27300059B	Buss (Pre)
C707, C708	352751011	100 μ F 25V, Elect.			SHIELDED PLATE
C706	352733311	330 μ F 10V, Elect.			
C915, C916	352782211	220 μ F 50V, Elect.		27150049	
C917, C918	352761011	100 μ F 35V, Elect.			
C921	352754711	470 μ F 25V, Elect.			

VARIABLE RESISTORS

R305 5148011 N16RGL250KMN30, Balance

RESISTORS

R710 441623914 390 Ω 1W
R719 441621214 120 Ω 1W
R723 441725614 560 Ω 2W
R724 441723014 300 Ω 2W
R725 441723314 330 Ω 2W
R905, R906 441623314 330 Ω 1W

SWITCHES

S301~S305 25035039 NPS-542-L04

RELAY

RL701 250166 or NRL-2P5A-DC12
25065037 or NRL-2P5A-DC12-02 or

NOTES:

DE: Non-Inductive Polyester Film Capacitor.
LD, SLD: Low Leakage Current Type Electrolytic Capacitor.
ST: Polystyren Film Capacitor.

MC. HEAD AMP. PC BOARD (NAAF-435) –PARTS LIST

.com
tics

CIRCUIT NO.	PARTS NO.	DESCRIPTION
TRANSISTORS		
Q201, Q202	2210834	2SA850(D)
	2210835	2SA850(E) or
Q203, Q204	2210844	2SC1735(D)
	2210845	2SC1735(E) or
CAPACITORS		
C201~C208	352724711	470 μ F 6.3V, Elect.
C209~C212	392880227	2.2 μ F \pm 20% 50V, LL
C215, C217	352764711	470 μ F 35V, Elect.

TAPE MONITOR PC BOARD (NATM-434)–PARTS LIST

CIRCUIT NO.	PARTS NO.	DESCRIPTION
SWITCHES		
S101	25030095	NRS-145-30ZL, Selector
S102	25030068	NRS-143-30A, Tape dubbing
S103	25030068	NRS-143-30A, Tape monitor

TONE CONTROL PC BOARD (NATS-374a)–PARTS LIST

CIRCUIT NO.	PARTS NO.	DESCRIPTION
CAPACITORS		
C403, C404	374122044	0.2 μ F \pm 5% 50V, DE
C407, C408	374121144	0.11 μ F \pm 5% 50V, DE
C409, C410	390882207	22 μ F 50V, SLD
C413, C414	372328214	820pF \pm 5% 50V, ST
VARIABLE RESISTORS		
R401	5104042	GH30E-196Kx2, Bass Control
R413	5104043	GH30E-171Kx2, Treble Control
ROTARY SWITCHES		
S401	25030072	NRS-143-30ZV, Bass Frequency shift
S402	25030072	NRS-143-30ZV, Treble Frequency shift

RECTIFIER PC BOARD (NAPS-437)–PARTS LIST

CIRCUIT NO.	PARTS NO.	DESCRIPTION
DIODES		
D901~D908	223841	GP-30G

BIAS STABILIZATION PC BOARD – PARTS LIST

CIRCUIT NO.	PARTS NO.	DESCRIPTION
TRANSISTOR		
Q06	2211183	2SC1740(R)
	2211184	2SC1740(S) or Bias Stabilization

NOTES:

DE: Non-Inductive Polyester Film Capacitor
 LD: Low Leakage Current Type Electrolytic Capacitor
 SLD: Low Leakage Current Type Electrolytic Capacitor
 ST: Polystyrene Film Capacitor

When replacing differential amplifier or push-pull amplifier transistors, be sure that transistors of one channel have the same h_{FE} ratings.

POWER AMP. PC BOARD VIEW FROM BOTTOM SIDE

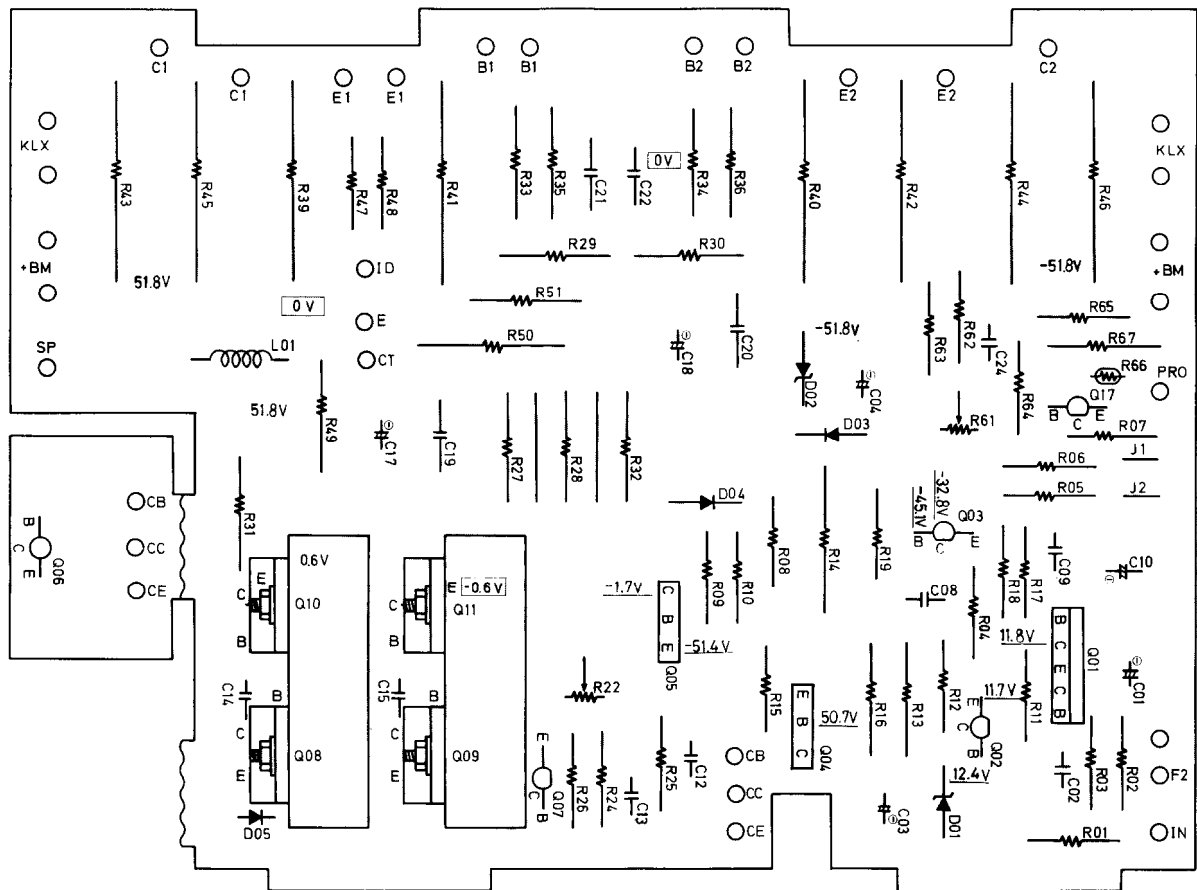

POWER AMP. PC BOARD (NADA-405a) – PARTS LIST

CIRCUIT NO.	PARTS NO.	DESCRIPTION	CIRCUIT NO.	PARTS NO.	DESCRIPTION
TRANSISTORS			COIL		
Q01	2210700	2SC1583(O-001) Differential Amp.	L01	231001	S-1.3B
Q02	2210755	2SC1775A(E) Driver	CAPACITORS		
Q03	2210795	2SC1890A(E) Regulator Current	C01	392651001	10μF 25V LR
Q04	2210774	2SA818(Y) Driver	C03, C04	352744701	47μF 16V Elect.
Q05	2210784	2SC1628(Y) Driver	C17, C18	352771001	10μF 63V Elect.
Q07	2211183	2SC1740(R) Complement	C22	374131045	0.1μF ±10% 100V DE
	2211184 or	2SC1740(S) Complement	RESISTORS		
Q08	2210782	2SC1628(O) Complement	R13	441628224	8.2KΩ 1W Metal Oxide Film
	2210784 or	2SC1628(Y) Complement	R14	441721534	15KΩ 2W Metal Oxide Film
Q09	2210772	2SA818(O) Complement	R29, R30	441624704	47Ω 1W Metal Oxide Film
	2210774 or	2SA818(Y) Complement	R31, R32	451631004	10Ω 1W Metal
Q10	2200552	2SC1669(O) Complement	R33~R36	451630274	2.7Ω 1W Metal
	2200553 or	2SC1669(Y) Complement	R39~R42	48114795	0.47Ω 5W Cement
Q11	2200562	2SA839(O) Complement	R43~R46	48193395	0.33Ω 3W Cement
	2200563 or	2SA839(Y) Complement	R49	451630684	6.8Ω 1W Metal
Q12, Q14	2200762	2SD675(B) Power Amp.	R50	451731004	10Ω 2W
	2200763 or	2SD675(C) Power Amp.	R66	4000003	D22A Thermistor
Q13, Q15	2200772	2SB655(B) Power Amp.	VARIABLE RESISTORS		
	2200773 or	2SB655(C) Power Amp.	R22	5221017	R-HK1KB3S
Q17	2210795	2SC1890A(E) Current Detector Amp.	R61	5221007	R-HK2.2KB3S
DIODES			HEAT SINK		
D01	223910	WZ-120 Zener	27160011	RAD-05	
D02	223928	WZ-061 Zener			
D03, D04	4000031	M8513A(O) Varistor			
D05	223105	1S1555			

SCHEMATIC DIAGRAM
 Model A-10

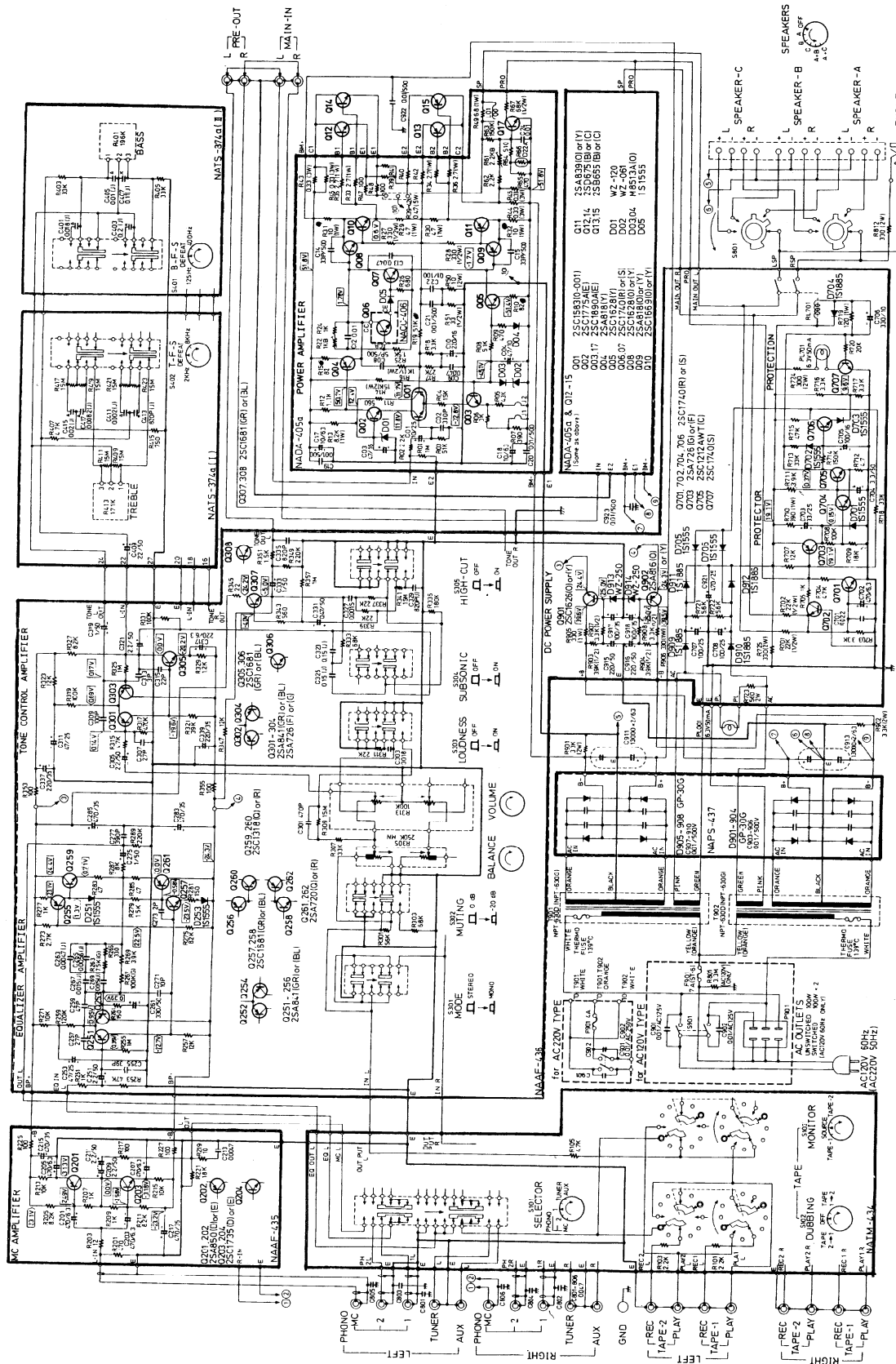

NOTE:
 1. DC VOLTAGES (V_{DC}) ARE MEASURED WITH VTVM TO CHASSIS AT NO SIGNAL APPLIED.
 2. UNLESS OTHERWISE SPECIFIED, RESISTORS ARE IN OHMS, 45%, YAW. CAPACITORS ARE IN μ F, 50VDC.
 3. POLARITY OF ELECTROLYTIC CAPACITORS (—/+—) ARE IN μ F/WV.
 4. SYMBOL X NON-INDUCTIVE POLYESTER FILM CAPACITOR * NON-INFLAMMABLE RESISTOR. S 1 FOR ACC20V 50HZ TYPE.

Tolerance	S	K	M	B	Z	D	F	G
TOL	±5%	±10%	±20%	±100%	±90%	±105%	±10%	±2%

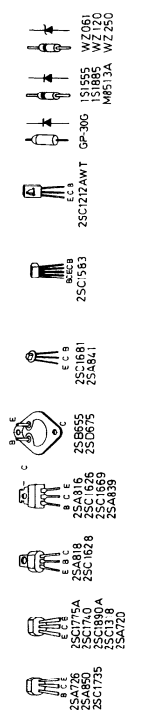

SERVICE PROCEDURES

1. IDLING CURRENT ADJUSTMENT

Connect the DC voltmeter between ID-CT terminals.

Adjust the voltage to $40 \pm 10\text{mV}$ with R22.

NOTES: Adjust after switching on for 10 minutes.

Open Load Volume ... Minimum

2. CURRENT DETECTOR LEVEL ADJUSTMENT

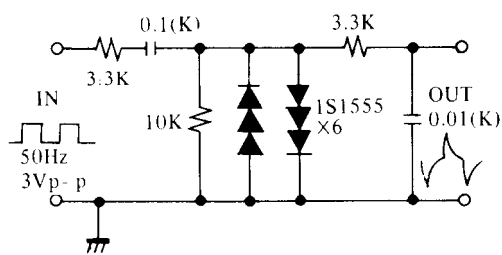
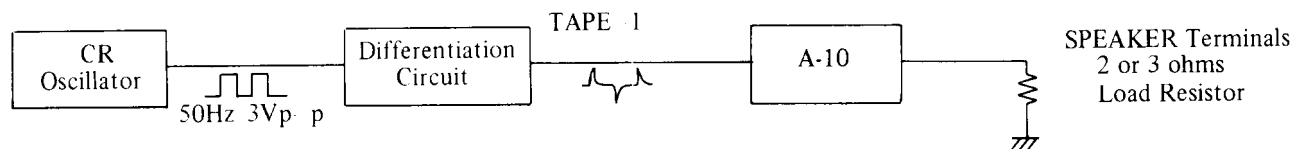

Differentiation Circuit

Apply a tone burst signal to the TAPE-1 terminal, connect a 2 ohm hollow resistor to the speaker terminals and adjust variable resistor R61 so that the relay is operated at maximum volume. Confirm that the relay is not operated when the 3 ohm hollow resistor is connected.

NOTES: Adjust after switching on for 10 minutes.

VOLUME – Maximum

3. CENTER VOLTAGE CHECK

When the transistor of the differential amp (Q1) of the power amplifier (NADA-405a) or the constant current circuit (Q3) has been replaced, check the center voltage.

(Check method)

Connect a DC VTVM between the CT-E terminals and check if the reading of the DC VTVM is within 30mV of the rated voltage.

When outside the rated voltage, cut or connect the jumper wires (J1, J2) by referring to the below table. Perform this check 10 minutes after the power switch has been set to ON.

J1	J2	Center Voltage
Connect	Connect	0mV
Connect	Cut	-9 ~ -13mV
Cut	Connect	-18 ~ -22mV
Cut	Cut	-34 ~ -38mV

NOTES:

The center voltage when jumpers J1, J2 are connected was assumed to be 0mV.

4. REMOVAL OF THE POWER AMP. PC BOARD

- (1) Remove four screws which hold the top cover to the chassis and lift off the top cover.
- (2) Remove four screws which hold the cover to the heat sink.

PACKING PROCEDURES

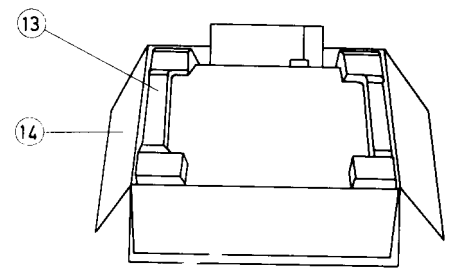
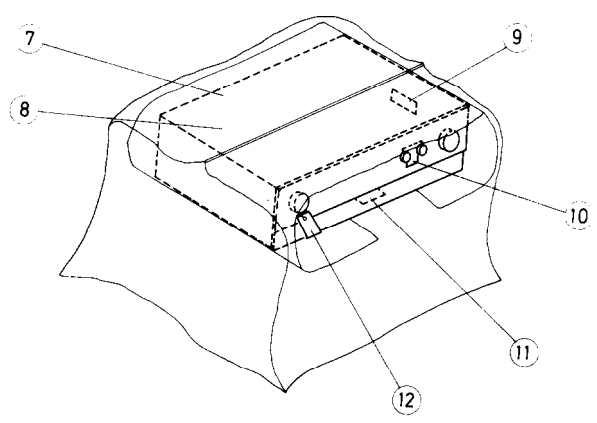
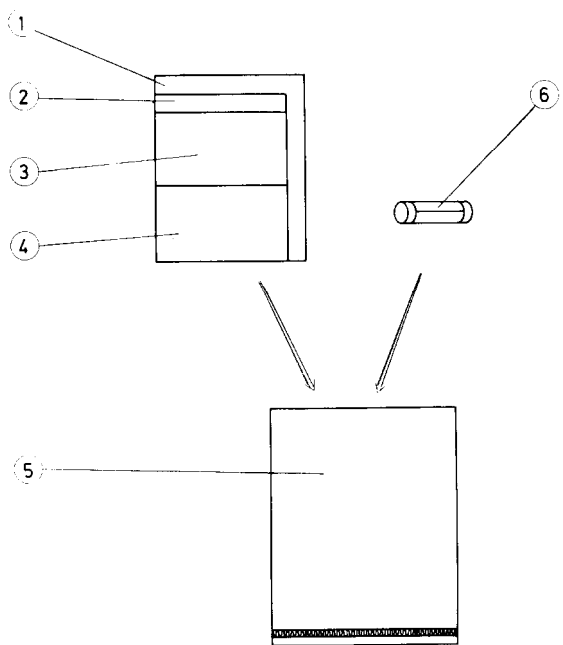

PARTS LIST

REF. NO.	DESCRIPTION	PARTS NO.	
		U.S.A. Model	220V Model
1	Instruction manual	29340237	29340240
2	Service station list	29358001	-
3	Caution card for warranty card	29355046	-
4	Warranty card	29365003	29365001-1 (only germany Model)
5	250x350mm, Poly bag	29100006	29100006
6	7A ST-6, Fuse	252052	-
7	850x650mm, Poly bag	29100027A	29100027A
8	500x1,000mm, Protection sheet	290008	290008
9	Caution label A	282969	-
10	Label	282742	282742
11	Caution label	293041	-
12	Cabinet composite tag	29380025	-
13	Pad	29090234	29090234
14	Carton box	29050152	29050152
	Shorted pin	250153	250153
	Pad D	29090263	29090263

1. All printed materials and fuse are placed in a poly bag and taped.
2. The cabinet composite tag is attached to the speaker switch.
3. The label is inserted between tape monitor and selector switch shaft.
4. Six shorted pins are inserted in the phono terminals.

INTERNATIONAL DIVISION

The 24th MORI Bldg., 23-5, Nishishinbashi 3-chome, Minato-ku, Tokyo, Japan PHONE: TOKYO(432)6981
TELEX: 242-3551

ONKYO U.S.A. CORPORATION

EASTERN OFFICE
42-07 20th Avenue Long Island City N.Y. 11105 U.S.A. PHONE:

ONKYO U.S.A. CORPORATION

MIDWEST OFFICE
935 Sivert Drive, Wood Dale, Ill. 60191 U.S.A. PHONE: Chicago 312(595) 2970

ONKYO Deutschland G.M.B.H ELECTRONICS

8034 München-Germering Industriestrasse 18 West Germany PHONE: München 089-845041 TELEX: 05-21726