

Service Manual

AM/FM STEREO RECEIVER

SX-580

 **PIONEER**[®]

MODEL SX-580 COMES IN FOUR VERSIONS DISTINGUISHED AS FOLLOWS:

Type	Voltage	Remarks
KU	120V only	U.S.A. model
KC	120V only	Canada model
S	110V, 120V, 220V, 240V (Switchable)	General export model
S/G	110V, 120V, 220V, 240V (Switchable)	U.S. military model

This service manual is applicable to the KU type. When repairing the KC, S, S/G types, please see the additional service manual.

CONTENTS

1. SPECIFICATIONS	3	9. EXPLODED VIEWS	
2. FRONT PANEL FACILITIES	5	9.1 External Part	16
3. BLOCK DIAGRAM	7	9.2 Internal Part	17
4. CIRCUIT DESCRIPTION		10. PACKING	20
4.1 Tuner Section	7	11. SCHEMATIC DIAGRAMS, P.C. BOARD PATTERNS AND PARTS LIST	
4.2 Audio Section	8	11.1 Miscellanea	20
5. DISASSEMBLY	9	11.2 Schematic Diagram	22
6. PARTS LOCATIONS		11.3 P.C. Board Connection Diagram	24
6.1 Front Panel View	10	11.4 Front-end (GWB-101)	27
6.2 Front View With Panel Removed	10	11.5 Terminal Assembly (GWX-181)	28
6.3 Top View	11	11.6 De-emphasis Assembly (GWX-180)	28
6.4 Rear Panel View	11	11.7 LED Assembly (GWX-177)	28
7. DIAL CORD STRINGING	12	11.8 Headphone Assembly (GWX-179)	28
8. ADJUSTMENTS		11.9 Fuse Assembly (GWX-178)	28
8.1 AM Tuner	13	11.10 Tuner and AF Assembly (GWM-113)	29
8.2 FM Tuner	14		

1. SPECIFICATIONS

Semiconductors

FETs	3
ICs	5
Transistors	17
Diodes	29

Amplifier Section

Continuous Power Output of 20 watts* per channel, min., at 8 ohms or 25 watts per channel at 4 ohms from 20 Hertz to 20,000 Hertz with no more than 0.3% total harmonic distortion.

Total Harmonic Distortion (20 Hertz to 20,000Hertz, from AUX)

continuous rated power output . . . No more than 0.3%
10 watts per channel power output,

8 ohms No more than 0.1%

1 watt per channel power output,
8 ohms No more than 0.08%

Intermodulation Distortion (50 Hertz: 7,000 Hertz = 4:1, from AUX)

continuous rated power output . . . No more than 0.3%
10 watts per channel power output,

8 ohms No more than 0.1%

1 watt per channel power output,
8 ohms No more than 0.08%

Damping Factor (20 Hertz to 20,000 Hertz, 8 ohms) . . . 25
Input Sensitivity/Impedance

PHONO. 2.5mV/50 kilohms

AUX. 150mV/50 kilohms

TAPE PLAY 150mV/50 kilohms

PHONO Overload Level (1kHz, T.H.D.: 0.1%) . . . 150mV

Output (Level/Impedance)

TAPE REC 150mV

SPEAKERS A, B, A+B

HEADPHONES Low impedance

Frequency Response

PHONO(RIAA Equalization). 30Hz to 15,000Hz ± 0.5 dB

AUX, TAPE PLAY 5Hz to 100,000Hz ± 3 dB

Tone Control

BASS +8dB, -8dB (100Hz)

TREBLE +10dB, -10dB (10kHz)

Loudness Contour (Volume control set at -40dB position)

. +6dB (100Hz), +3dB (10kHz)

Hum and Noise (IHF, short-circuited, A network, rated power)

PHONO. 73dB

AUX, TAPE PLAY 90dB

FM Section

Usable Sensitivity

MONO 10.8dBf (1.9 μ V)

50dB Quieting Sensitivity

MONO 16.7dBf (3.8 μ V)

STEREO 36.7dBf (38 μ V)

Signal-to-Noise Ratio at 65dBf

MONO 80dB

STEREO 70dB

Distortion at 65dBf

100Hz. . . MONO 0.07%

STEREO 0.15%

1kHz . . . MONO 0.07%

STEREO 0.15%

6kHz . . . MONO 0.2%

STEREO 0.25%

Frequency Response 30Hz to 15,000Hz $^{+0.2}_{-1.0}$ dB

Capture Ratio 1.0dB

Selectivity 60dB

Spurious Response Ratio 65dB

Image Response Ratio 65dB

IF Response Ratio 90dB

AM Suppression Ratio 50dB

Muting Threshold 19.2dBf (10 μ V)

Stereo Separation . . . 40dB (1kHz), 30dB (30Hz~15kHz)

Subcarrier Production Ratio 50dB

SCA Rejection Ratio 65dB

Antenna Input 300 ohms balanced

75 ohms unbalanced

AM Section

Sensitivity (IHF, ferrite antenna) 300 μ V/m

(IHF, ext. antenna) 15 μ V

Selectivity 26dB

Signal-to-Noise Ratio 50dB

Image Response Ratio 40dB

IF Response Ratio 40dB

Antenna Built-in ferrite loopstic antenna

Miscellaneous

Power Requirements 120V, 60Hz

Power Consumption 80W (UL), 160VA (CSA)

Dimensions 435(W) x 144.5(H) x 314(D) mm

17-1/8(W) x 5-5/8(H) x 12-3/8(D) in

Weight Without package: 8.3kg (18lb 5oz)

With package: 9.7kg (21lb 6oz)

Furnished Parts

FM T-type antenna	1
Operating instructions	1

**Measured pursuant to Federal Trade Commission's Trade Regulation Rule on Power Output Claims for Amplifiers.*

*NOTE:
Specifications and design subject to possible modification without notice due to improvements.*

2. FRONT PANEL FACILITIES

POWER METERS

These meters allow you to read out the rated power level when speakers with a nominal impedance of 8 ohms are connected to the receiver's speaker terminals.

NOTE:

These values are related to the impedance of the speakers and they vary according to the frequency. In order to find out the exact output level, connect an 8-ohm dummy load instead of the speakers.

POWER SWITCH

Depress this button (in the ON position) to supply power to the receiver. There will be a short delay when it is set to ON, because the muting circuit has been actuated to suppress the unpleasant noise that is sometimes generated when the power is switched on and off.

PHONES JACK

Plug the headphones into this jack when you want to listen through your stereo headphones. Release both **SPEAKERS** buttons if you want to listen to the sound through your headphones only (This means that both buttons will be released).

SPEAKERS SWITCHES

Depress the button corresponding to the speakers connected to the **SPEAKERS** terminals (A or B) on the rear panel. You can depress both of these buttons to listen to sound from two pairs of speaker systems at the same time.

BASS AND TREBLE CONTROLS

Use these controls to adjust the bass and the treble. If you turn the **BASS** control to the right from its center position, you will be able to emphasize the sound in the low-frequency range. Conversely, turning this control left from the center position will attenuate the sound. You can use the **TREBLE** control to adjust the sound in the high-frequency range.

TAPE MONITOR INDICATOR

With the **TAPE MONITOR** switch set to ON, the **TAPE MONITOR** indicator lights up. This lamp indicates the receiver is monitoring or playing back the tape on the tape deck connected to the **TAPE** jacks.

SOURCE INDICATOR

With the **TAPE MONITOR** switch set to OFF, the **SOURCE** indicator lights up. This lamp indicates the receiver is playing the program source; AM broadcasting, FM broadcasting, record on the turntable, or another component connected to the **AUX** jacks.

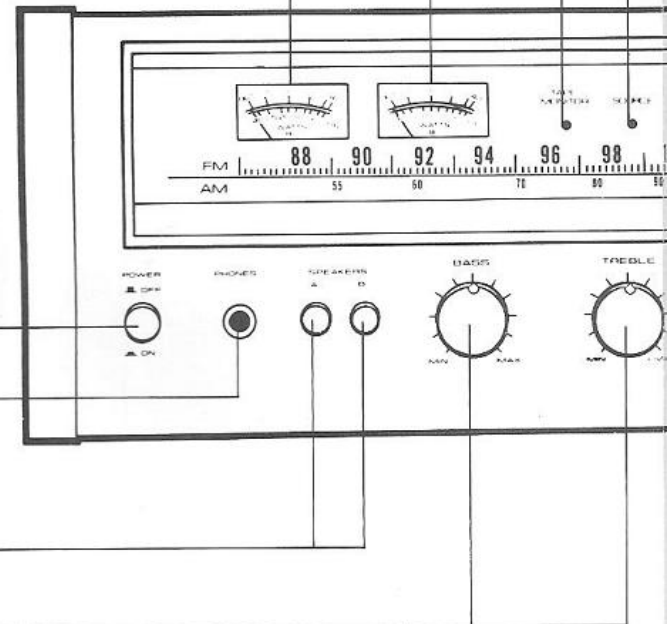

FUNCTION SWITCH

Use this switch to select the program source. For a second after the switch is selected, no sound will be heard. This is due to the operation of the muting circuit, which suppresses the unpleasant switching noise generated when the **FUNCTION** switch is selected.

AM: When listening to AM broadcasting.

FM: When listening to FM broadcasting.

The **STEREO** indicator lights up when the receiver is tuned in to an FM stereo broadcast.

PHONO: When playing a record on the turntable connected to the **PHONO** jacks.

AUX: When listening to an audio component connected to the **AUX** jacks.

DIAL POINTER

This pointer indicates the broadcasting stations.

STEREO INDICATOR

This indicator lights up when the receiver is tuned in to receive a stereo broadcast.

AM/FM TUNING METER

When tuning in to FM stations, position the meter pointer in the center of FM area for optimum reception. In the case of AM stations, tune for maximum meter deflection toward the right of the scale.

TUNING KNOB

Use this to tune in to broadcasting stations. Select the station and tune for optimum reception by observing the dial scale and the AM/FM tuning meter.

VOLUME CONTROL

Use this control to adjust the output level to the speakers and headphones. Turn it clockwise to increase the output level. No sound will be heard if you set it to MIN.

LOUDNESS SWITCH

Depress this button (ON position) when listening at a low volume. The frequency response of the human ear varies according to the listening volume, and setting this switch to the ON position compensates for hearing response by emphasizing the bass and treble.

BALANCE CONTROL

Use this control to balance the volume of the left and right channels. First, however, set the mode select switch (MODE/FM MUTE) to MONO. If the sound appears to be louder on the right, it means that the volume of the right channel is higher. Turn the BALANCE control to the left and adjust. Conversely, if the sound appears to be louder on the left, it means that the volume of the left channel is higher. Therefore, turn the BALANCE control to the right and adjust. After adjusting, return the mode select switch (MODE/FM MUTE) to STEREO.

TAPE MONITOR SWITCH

Depress this button with a tape deck which is connected to the TAPE jacks (REC and PLAY) when you want to monitor the playback or recording of a tape. When you depress this button the TAPE MONITOR indicator will come on.

MODE/FM MUTING SWITCH

This switch is a combination of the FM muting switch and the mode select switch. When the button is left undepressed (ON position) the reproduction is in STEREO mode, while the FM muting function acts to suppress unpleasant interstation noise while tuning between FM stations when listening to FM broadcasting. When the button is depressed (OFF position), however, reproduction is in MONO mode, while the FM muting function does not act, thus enabling suitable reception of weak radio stations when tuning in to the FM broadcasting station.

NOTE:

Recording stereophonically with the mode select switch (MODE/FM MUTE) in the MONO position may cause deterioration in channel separation.

NOTE:

Release this button (OFF position) when listening to a record or a broadcast. The SOURCE indicator lights up at this time.

3. BLOCK DIAGRAM

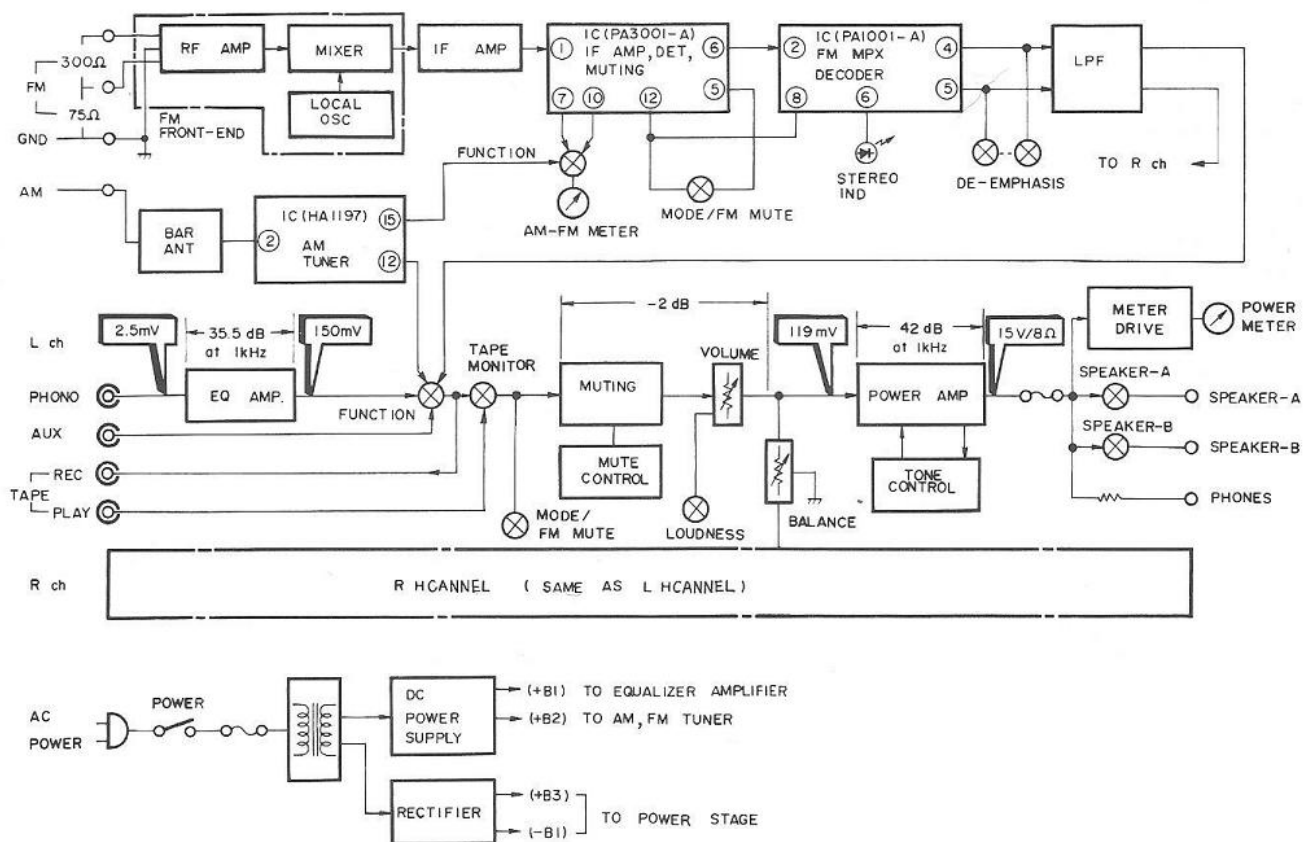

4. CIRCUIT DESCRIPTION

4.1 TUNER SECTION

AM Tuner

The AM tuner stage consists of a 2-ganged tuning capacitor, an IC (HA1197) and a ceramic filter. See page 21 for details of the internal structure of HA1197 which contains a 1-stage RF amplifier, converter, 2-stage IF amplifier, detector, and AGC circuit.

FM Front-end

The FM front-end consists of a 3-ganged tuning capacitor, a dual-gate MOS FET equipped 1-stage RF amplifier, a local oscillator and a mixer. The output of the local oscillator (a modified Clapp circuit employing a single transistor) is applied to the base of the mixer transistor.

IF Amplifier and Detector

This stage is made up of one IC, one transistor, are two dual-element ceramic filters. The NPN transistor inserted between the filters is employed for IF amplifier impedance matching purposes. The IC (PA3001-A) in the following stage incorporates

IF amplifiers, quadrature detector, meter drive and FM muting circuit, etc. See the block diagram on page 21 for the internal structure of this IC.

Multiplex Decoder

The sub-carrier generator (PLL system), NFB demodulator, automatic pilot canceller, and stereo/mono automatic switch are also built from an IC (PA1001-A). With the addition of a few CR elements, a multiplex decoder of high SN ratio and low distortion has been achieved (Again, refer to page 21 for further details of this IC). A major feature of the PA1001-A is the automatic pilot canceller. This circuit detects the level of the 19kHz pilot signal, and automatically adjusts to that level to cancel out the pilot signal completely. This has made the designing of the low-pass filter in the following stage very much easier, and has further extended the frequency response at the high end.

The output signal from the multiplex decoder is passed on via the de-emphasis circuit and AF amplifier (which serves as both low-pass filter and crosstalk canceller) to the FUNCTION switch.

4.2 AUDIO SECTION

Equalizer Amplifier

The phono equalizer amplifier is a collector-to-emitter feedback-type 2-stage direct-coupled amplifier, designed with a gain of 35.5dB (1kHz), a phono overload level of 150mV (1kHz, THD 0.1%), and equalizer deviation of ± 0.5 dB (30Hz–15kHz).

Power Amplifier

The power amplifier, which includes a hybrid IC (STK-0029) in the power stage, is a first-stage differential amplifier all-stage direct-coupled OCL circuit. This IC features an inverted Darlington connection quasi-complementary circuit power stage integrated with the bias circuit. The output power obtainable with an 8-ohm load is 20 watts (20–20,000Hz, THD 0.3%).

The tone controls (BASS, TREBLE) are operated by changing the frequency response of the power amplifier NFB circuit.

Output Meter Drive Circuit

Fundamentally, this circuit is the same as those employed in the SA-7700 and the SA-6700. A wide meter range is obtained by compressing the dynamic range of the output signal by taking advantage of the initial portion of the diode $V_F - I_F$ relation.

Audio Muting Circuit

The FET gate circuit connected to the input of the power amplifier stage serves as a muting circuit which eliminates unwanted switching noises when the power supply is turned on and off and when the FUNCTION selector is used. The circuitry involved and the voltage changes at different points are shown in Figs. 1 & 2.

• When the power supply is turned ON

Since $-B_2$ is applied to the base of Q_2 very quickly, this transistor will remain off when the power supply is first turned on. And, since the $-B_1$ level is established more rapidly than the $+B_2$ level, the potential at point A will initially be lowered to the $-B_1$ level, thereby keeping the FET switched off, and preventing the application of any signal to the input of the power amplifier stage (i.e. the signals are muted during this period).

As the $+B_2$ level is gradually established, the potential of point A will also increase in response, resulting in the FET being turned on some 6 seconds later to terminate the muted condition.

• When the power supply is turned OFF

The $-B_2$ voltage level diminishes relatively rapidly, and Q_2 is turned on by the forward biasing (because $-B_1$ diminishes rather slowly). Consequently, the potential at point A is reduced to $-B_1$, and the FET is turned off. This muting status is achieved within 0.1 second after the power supply is turned off.

• When FUNCTION selector is operated

When the FUNCTION selector switch is at any of the selector positions, Q_1 will remain off due to $+B_1$ being applied to its base via the FUNCTION switch. But since this is a non-shorting type selector switch, the $+B_1$ being applied to the base of Q_1 will be interrupted whenever the position of the selector switch is changed. Both Q_1 and Q_2 will thus be turned on temporarily. As a result, the potential at point A will be reduced to $-B_1$, followed by the FET being turned off and the power amplifier stage being muted. However, once the FUNCTION selector switch has been completely switched to the next position, $+B_1$ will again be applied to the base of Q_1 , resulting in Q_1 and Q_2 being turned back off. The potential at point A will consequently increase (at a speed determined by the R_1, C_1 time constant) until the FET is turned on, and the muting condition terminated.

Note that when the TAPE MONITOR switch is ON, Q_1 will be disconnected from Q_2 , so the power amplifier stage will no longer be muted when the FUNCTION selector is operated.

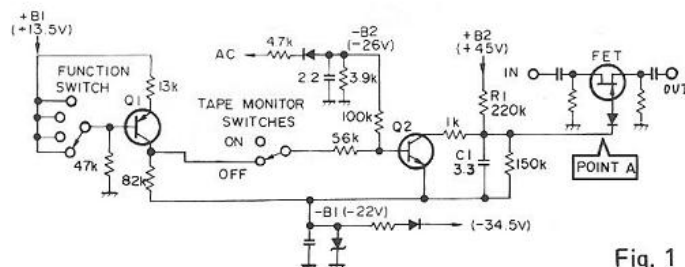

Fig. 1

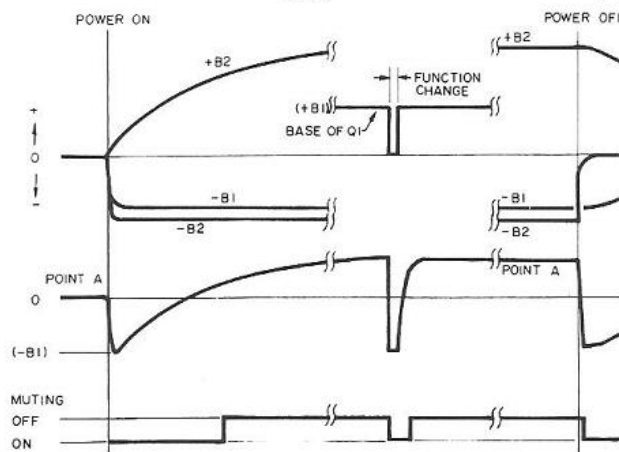

Fig. 2

5. DISASSEMBLY

Wooden Cover

Remove the 4 screws (1-4).

Bottom Plate

Remove the 10 screws (5-14).

Front Panel

Pull off all the knobs, and remove the 2 screws (15, 16) and 2 nuts (17, 18).

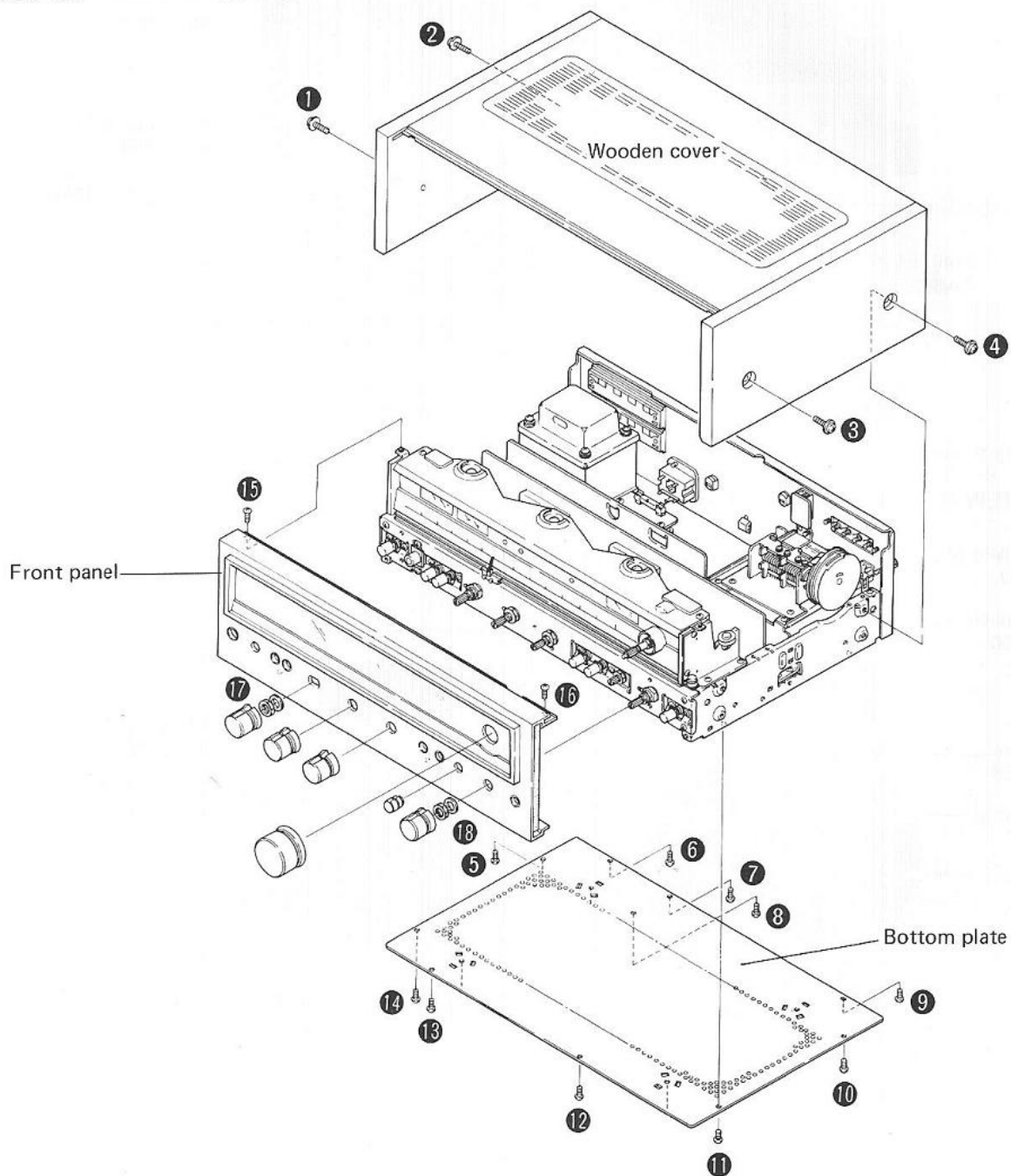
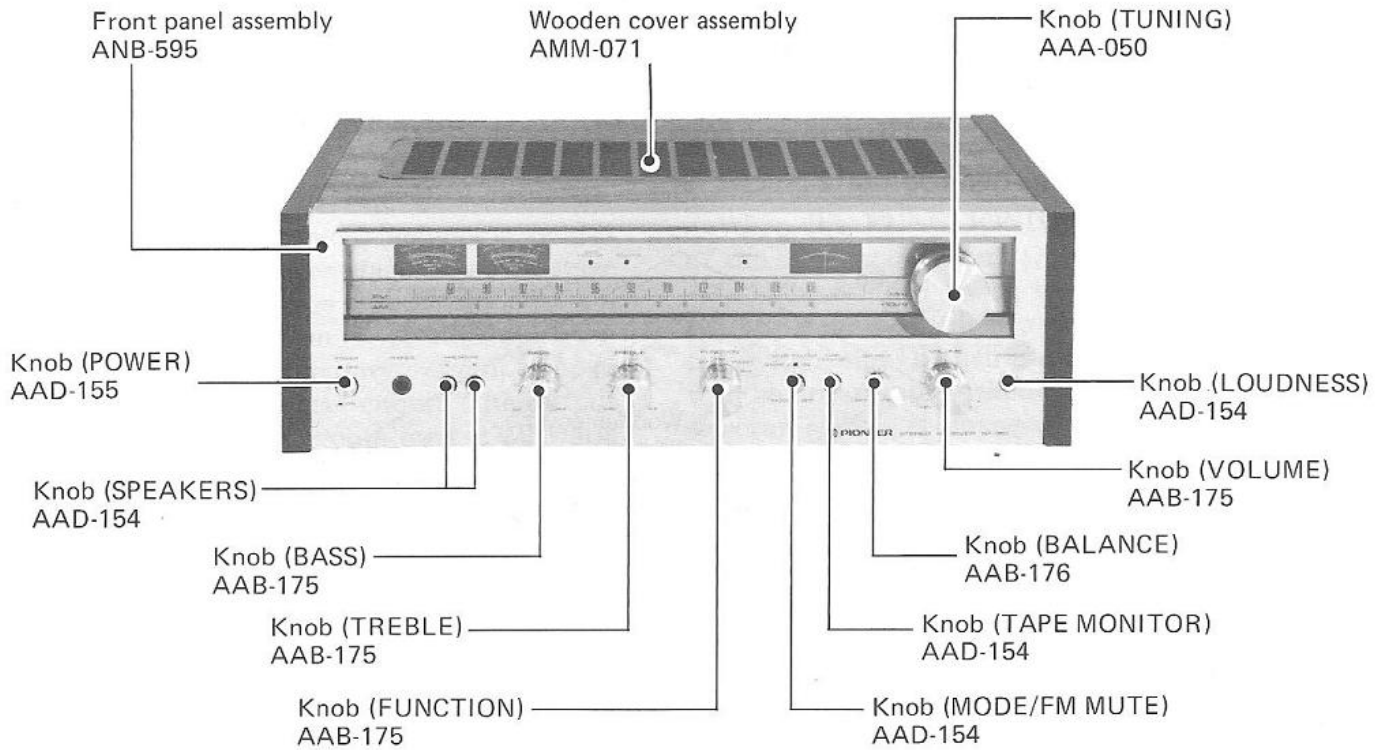

Fig. 3

6. PARTS LOCATIONS

6.1 FRONT PANEL VIEW



6.2 FRONT VIEW WITH PANEL REMOVED

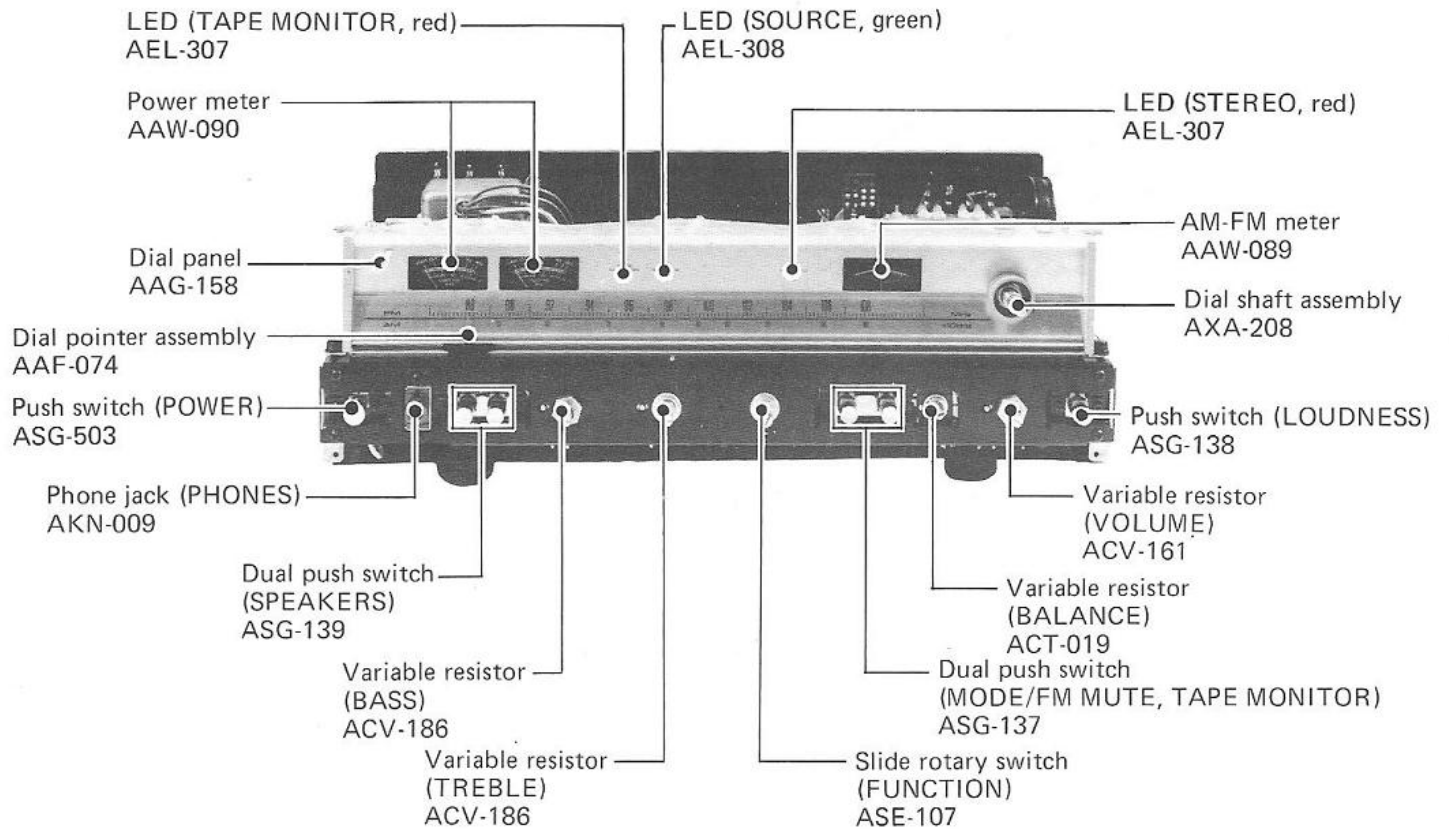

6.3 TOP VIEW

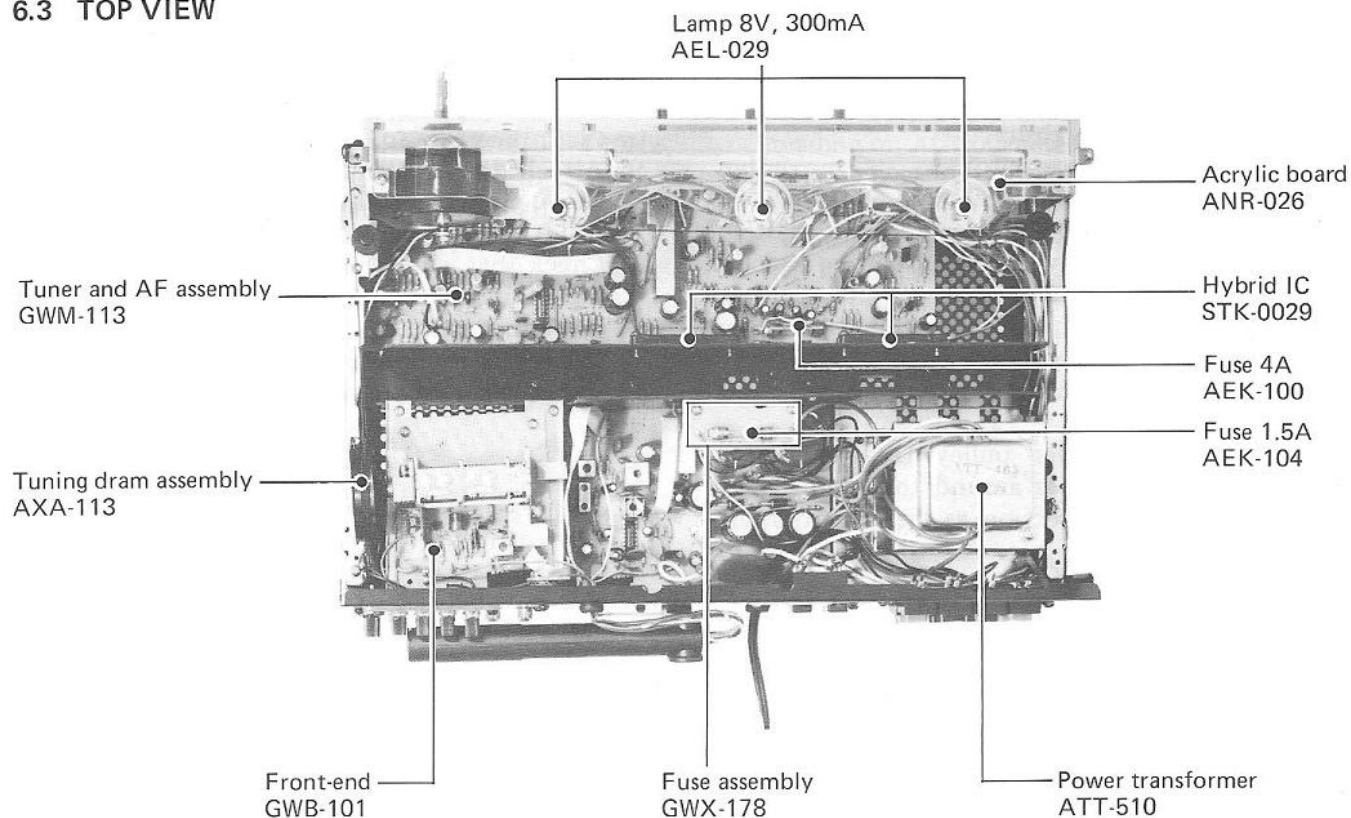

6.4 REAR PANEL VIEW

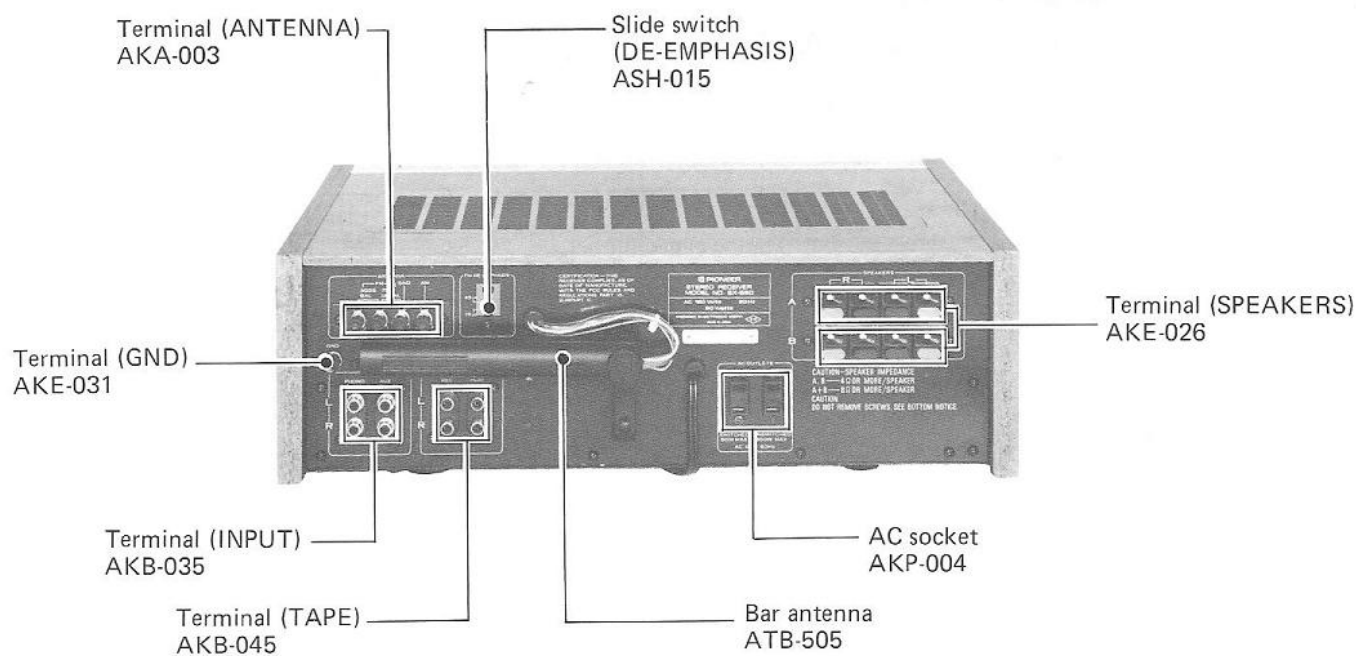

7. DIAL CORD STRINGING

1. Remove front panel (See page 9).
2. Remove the tuning drum from the tuning capacitor shaft.
3. Tie one end of the string to the stud on the inside of the tuning drum.
4. Set the tuning capacitor to its maximum capacity (with the vanes fully meshed).
5. Attach the tuning drum to the tuning shaft so that the fixing screw head is pointing exactly upwards.
6. Draw the string out through the gap cut in the tuning drum, and after passing it half-way round the drum, thread it successively over the pulleys A, B, C.
7. Pass the string over pulley D after having wound it three times around the tuning shaft (in a clockwise direction as viewed from the rear).
8. Tie the other end of the string to the hook on the spring, so that the string is tensioned, after passing it twice around the tuning capacitor.
9. Set the tuning capacitor to its maximum capacity (with the vanes fully meshed).
10. Attach the dial pointer to the string at the start point (at the extreme left-hand dial scale), and secure it firmly to the string.
11. Check that when the tuning shaft is turned, the dial pointer, tuning capacitor, etc., all move smoothly.
12. Paint-lock the knots on the string, and cut off the excess after painting.

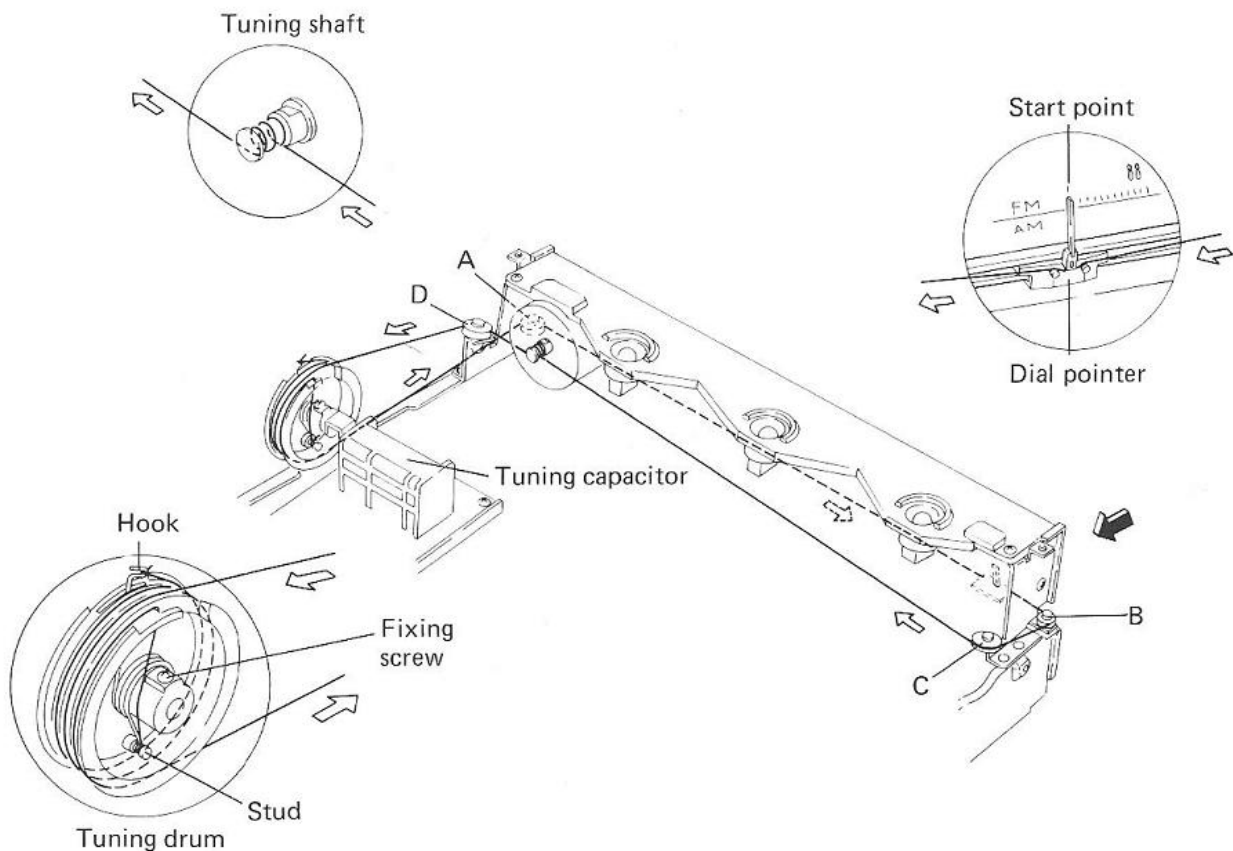

Fig. 4

8. ADJUSTMENTS

8.1 AM TUNER

1. Connect up the test instruments as shown in Fig. 5.
2. Set the FUNCTION switch to AM.
3. Set AM Signal Generator (AM SG) for 400Hz 30% modulation 100dB output.
4. Set the SX-580 dial indication and AM SG frequency for 600kHz.
5. Adjust T_3 core for maximum reading on AC voltmeter.
6. Set the SX-580 dial indication and AM SG frequency for 1400kHz.
7. Adjust TC_4 for maximum reading on AC voltmeter.
8. Set AM SG for 30dB output.
9. Set the SX-580 dial indication and AM SG frequency for 600kHz.
10. Adjust T_3 and bar antenna core for maximum reading on AC voltmeter.
11. Set the SX-580 dial indication and AM SG frequency for 1,400kHz.
12. Adjust TC_5 and TC_4 for maximum reading on AC voltmeter.
13. Repeat steps 9 to 12, alternately until adjustment at the one frequency requires no further re-adjustment at the other frequency.
14. Adjust F_4 core for give the maximum reading on the AC voltmeter.

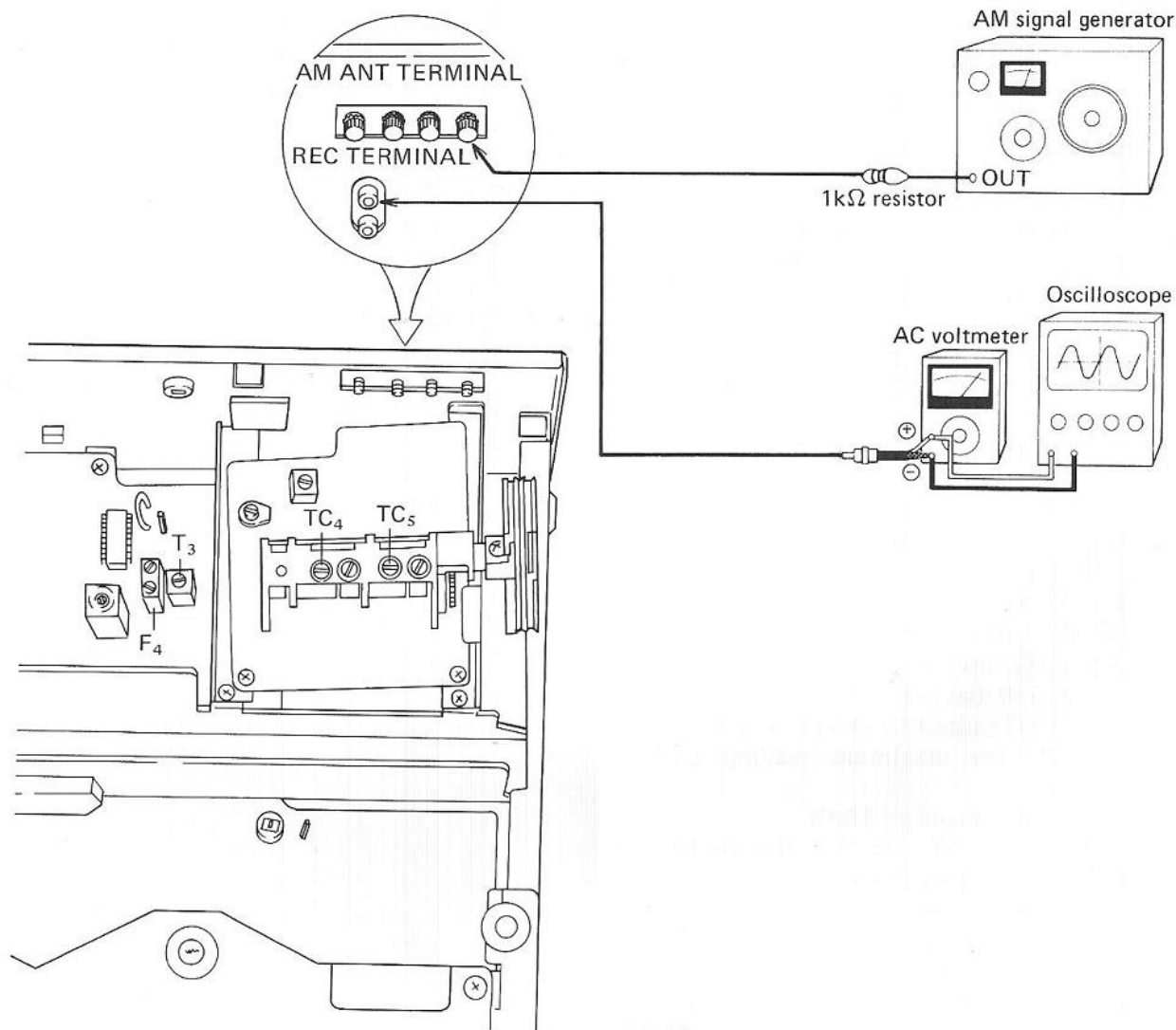

Fig. 5

8.2 FM TUNER

The tuning coil in the FM front end does not have an adjusting core. Consequently, tracking adjustments at 90MHz are performed by regulating the gap between rotor and stator of the tuning capacitors (VC_1 , VC_2 , VC_3). The expression adjust VC_1 , (VC_2 , VC_3) found in the text means that the two outer rotor blades of each of these tuning capacitors are to be extended outwards with spatula (Part No. GGK-066) as shown in Fig. 6.

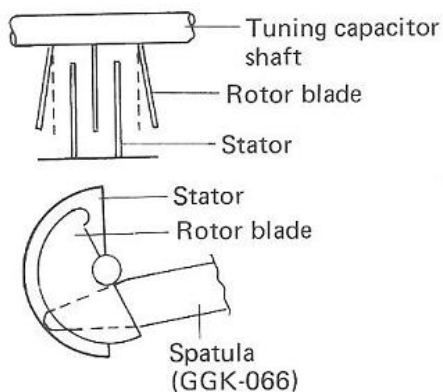

Fig. 6 Adjustment of Tuning Capacitor

1. Connect up the test instruments as shown in Fig. 7.
2. Set the FUNCTION switch to FM.
3. Turn the MODE/FM MUTE switch to OFF.
4. Set the dial pointer of the SX-580 to 106MHz.
5. Set the FM Signal Generator (FM SG) output to 106MHz at 106dB, with 100% modulation (75kHz deviation) for 400Hz. This modulation setting should be used for all the following adjustments.
6. Adjust TC_3 to give the maximum reading on the multitester (with DC 200 μ A range).
7. Adjust the primary (lower) core of T_2 so that the AM-FM meter (the FM tuning meter) indicator needle reads dead center.
8. Set the FM SG output to 15dB.
9. Adjust TC_1 and TC_2 to give the maximum reading on the multitester.
10. Set the SX-580 dial pointer to 90MHz.
11. Set the FM SG output to 90MHz at 106dB.
12. Adjust VC_3 for maximum reading on the multitester.
13. Set the FM SG output to 15dB.
14. Adjust VC_1 and VC_2 so that the multitester reading reaches a maximum.
15. Repeat the adjustments of VC_3 , VC_1 and VC_2 when the dial pointer is at 90MHz, and of TC_3 , TC_1 and TC_2 when the dial pointer is at 106MHz, alternately until adjustment at the one frequency requires no further re-adjustment at the other frequency.

16. Adjust the core of T_1 to give the maximum reading on the multitester.
17. De-tune the SX-580 (to a position at which only inter-station noise is heard), and adjust the primary (lower) core of T_2 so that the AM-FM meter indicator needle reads at dead center.
18. Set the FM SG output to 98MHz at 66dB.
19. Tune the SX-580 to a dial reading of 98MHz observe that the AM-FM meter is reading correctly at the center of the meter scale.
20. Adjust the secondary (upper) core of T_2 to give a minimum level of distortion.
21. Repeat the steps detailed in section 17 to 20 for the adjustment of the primary and secondary cores of T_2 until both requirements are fully met.
22. Set the SX-580 dial indication and FM SG frequency for 98MHz.
23. Set the MODE/FM MUTE switch to the ON, and check the muting threshold. If the muting threshold is more than 28dB, cut the jumper lead A.

Multiplex Decoder

24. Connect a MPX Signal Generator (MPX SG) to the external modulator terminals of the FM SG.
25. Connect the 19kHz pilot output signal from the MPX SG to the X-plates (horizontal input) of an oscilloscope, and use a probe to connect the Y-plates (vertical input) to the TP_2 terminal.
26. Set the FM SG output to 66dB, unmodulated.
27. Adjust VR_1 to freeze motion of the resulting Lissajous' figure.

NOTE:

Lissajous' figure adopts the general form shown in Figure 8 due to the fact that the MPX SG 19kHz pilot signal output is a sine wave, and the TP_2 terminal carries a 76kHz saw tooth wave as determined by the adjustment of VR_1 .

28. Turn the FM SG modulation mode setting to external modulation.
29. Adjust the MPX SG modulation settings to 1kHz, L + R, 90% modulation (67.5kHz deviation), with 10% pilot modulation (7.5kHz deviation).
30. Adjust the core of T_1 for minimum distortion in the 1kHz demodulated output from L or R channel.

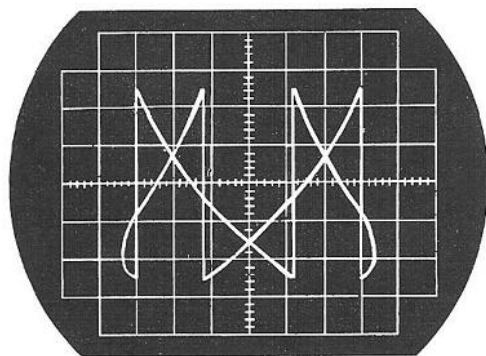
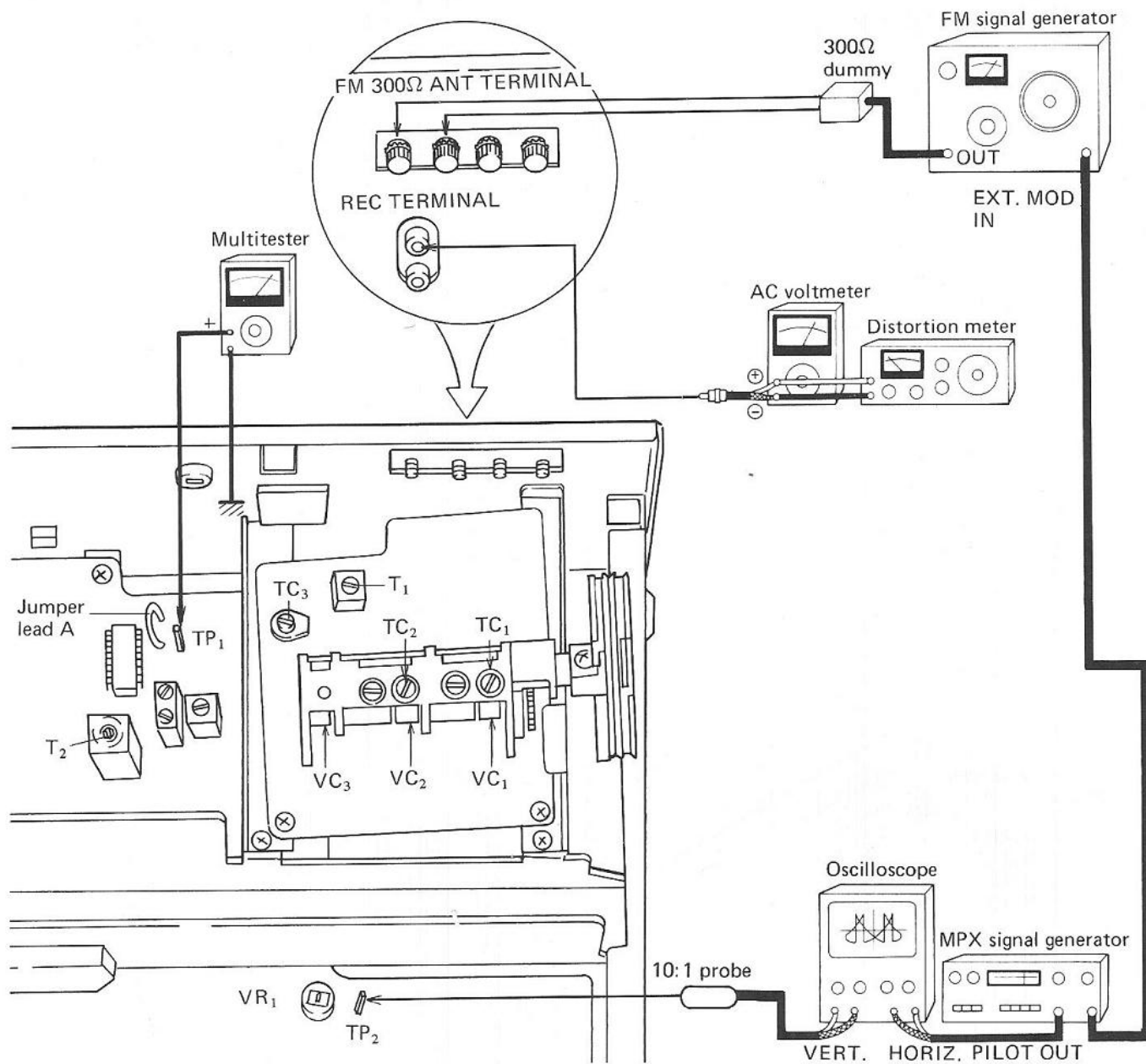



Fig. 8 Lissajous figure

Fig. 7

9. EXPLODED VIEWS

NOTE:

 marked parts cannot be supplied.

9.1 EXTERNAL PART

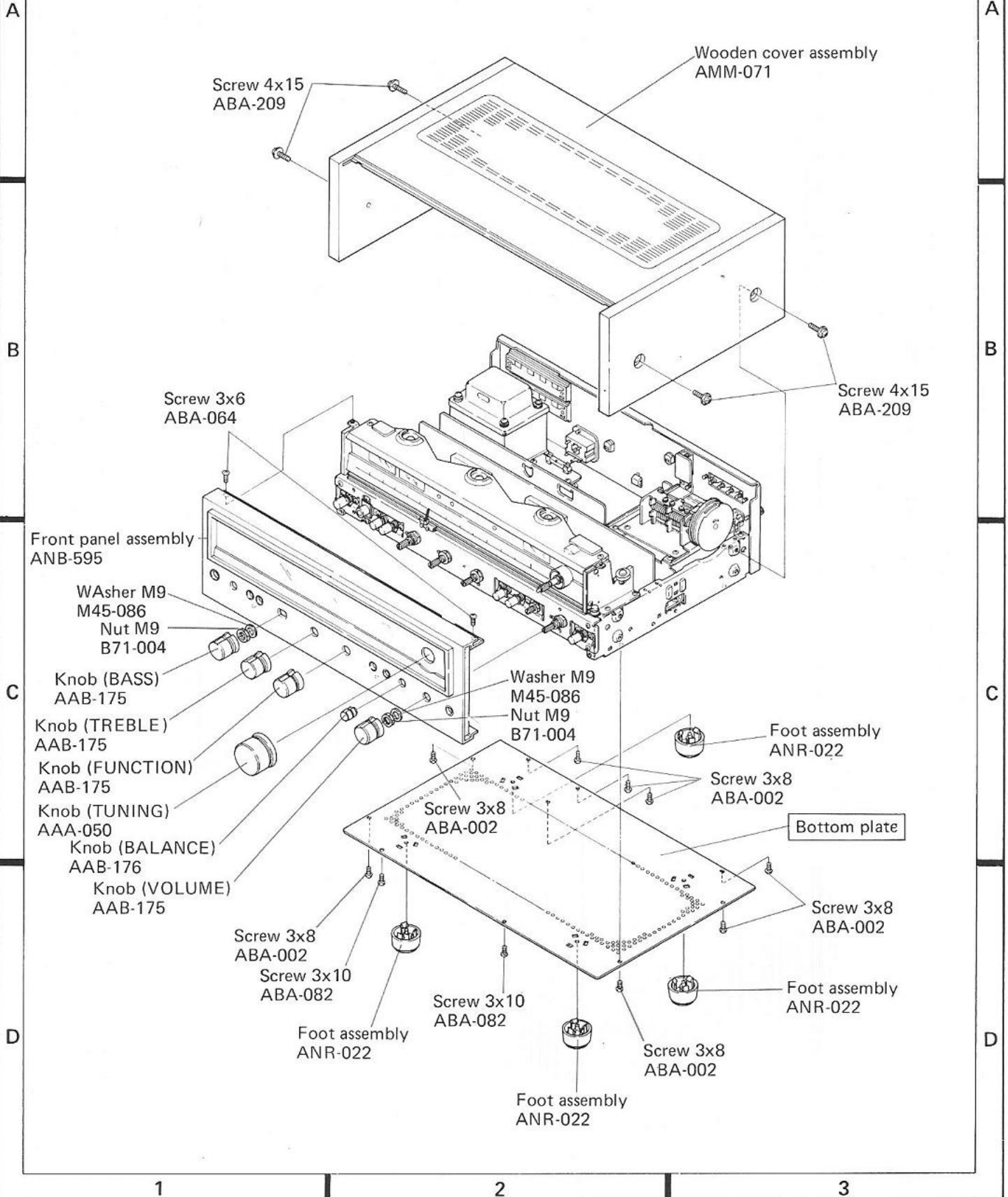

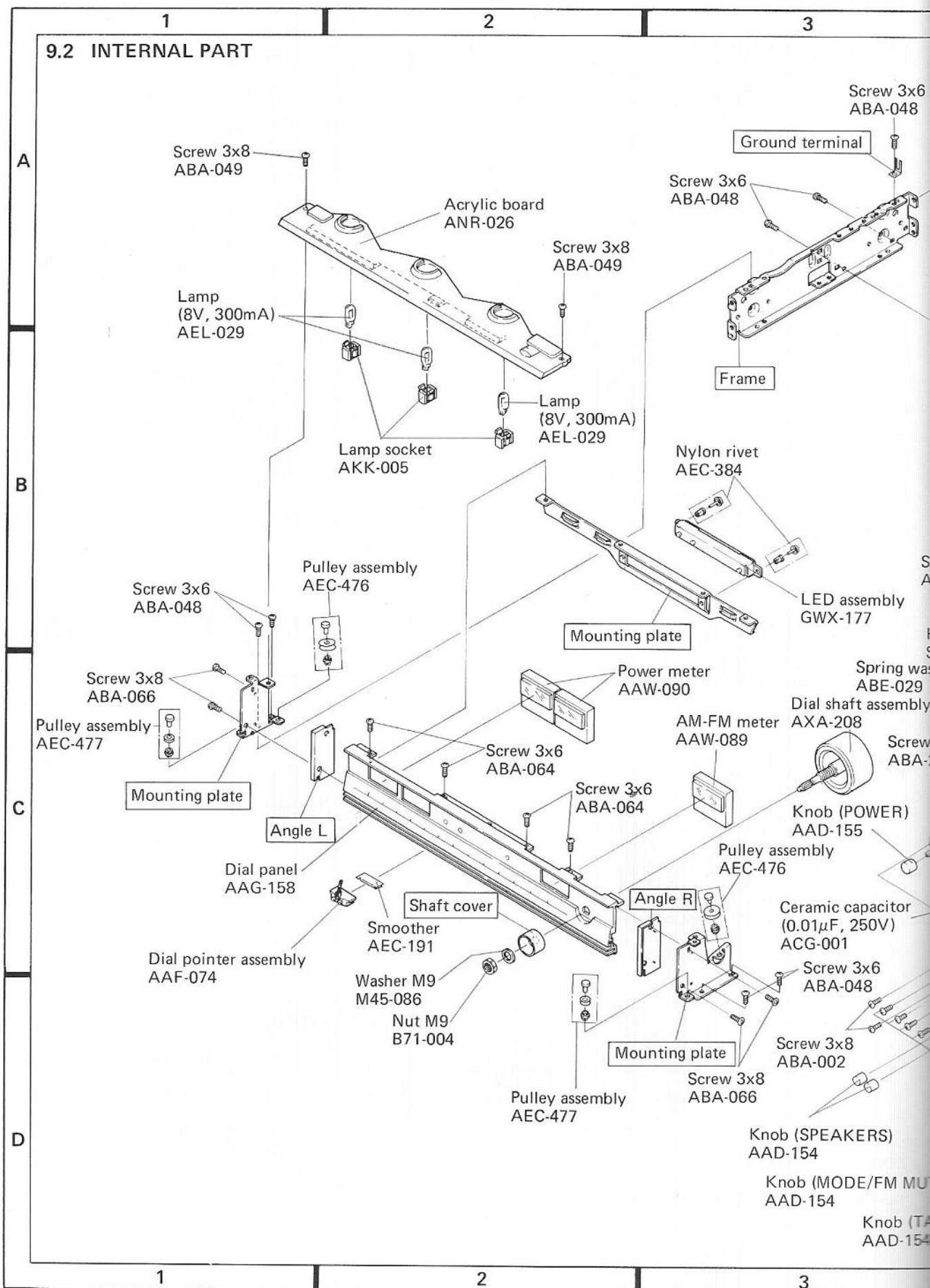

NOTE:
[] marked parts cannot be supplied.

See the next page.

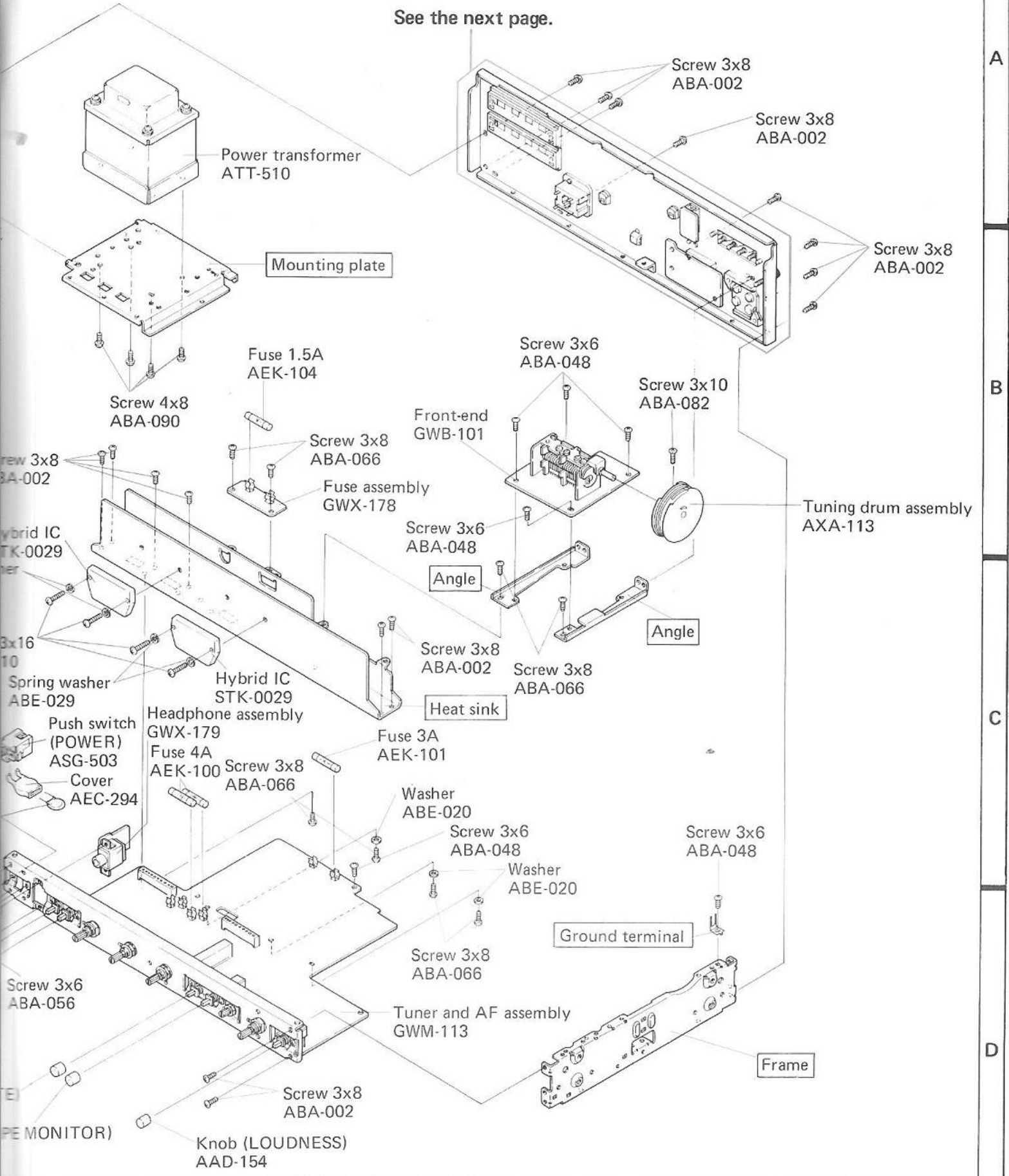

Power transformer
ATT-510

Mounting plate

Screw 3x8
ABA-002

Screw 3x8
ABA-002

Screw 3x8
ABA-002

Fuse 1.5A
AEK-104

Screw 3x6
ABA-048

Screw 3x10
ABA-082

Screw 4x8
ABA-090

Front-end
GWB-101

Tuning drum assembly
AXA-113

Screw 3x8
ABA-002

Screw 3x8
ABA-066

Fuse assembly
GWX-178

Screw 3x6
ABA-048

Angle

Angle

Hybrid IC
STK-0029

Screw 3x8
ABA-002

Screw 3x8
ABA-066

Heat sink

Screw 3x16
ABA-110

Spring washer
ABE-029

Hybrid IC
STK-0029

Fuse 3A
AEK-101

Headphone assembly
GWX-179

Fuse 4A
AEK-100

Screw 3x8
ABA-066

Washer
ABE-020

Screw 3x6
ABA-048

Screw 3x6
ABA-048

Washer
ABE-020

Push switch
(POWER)
ASG-503

Cover
AEC-294

Ground terminal

Screw 3x8
ABA-066

Tuner and AF assembly
GWM-113

Screw 3x6
ABA-056

Frame

Screw 3x8
ABA-002

Knob (LOUDNESS)
AAD-154

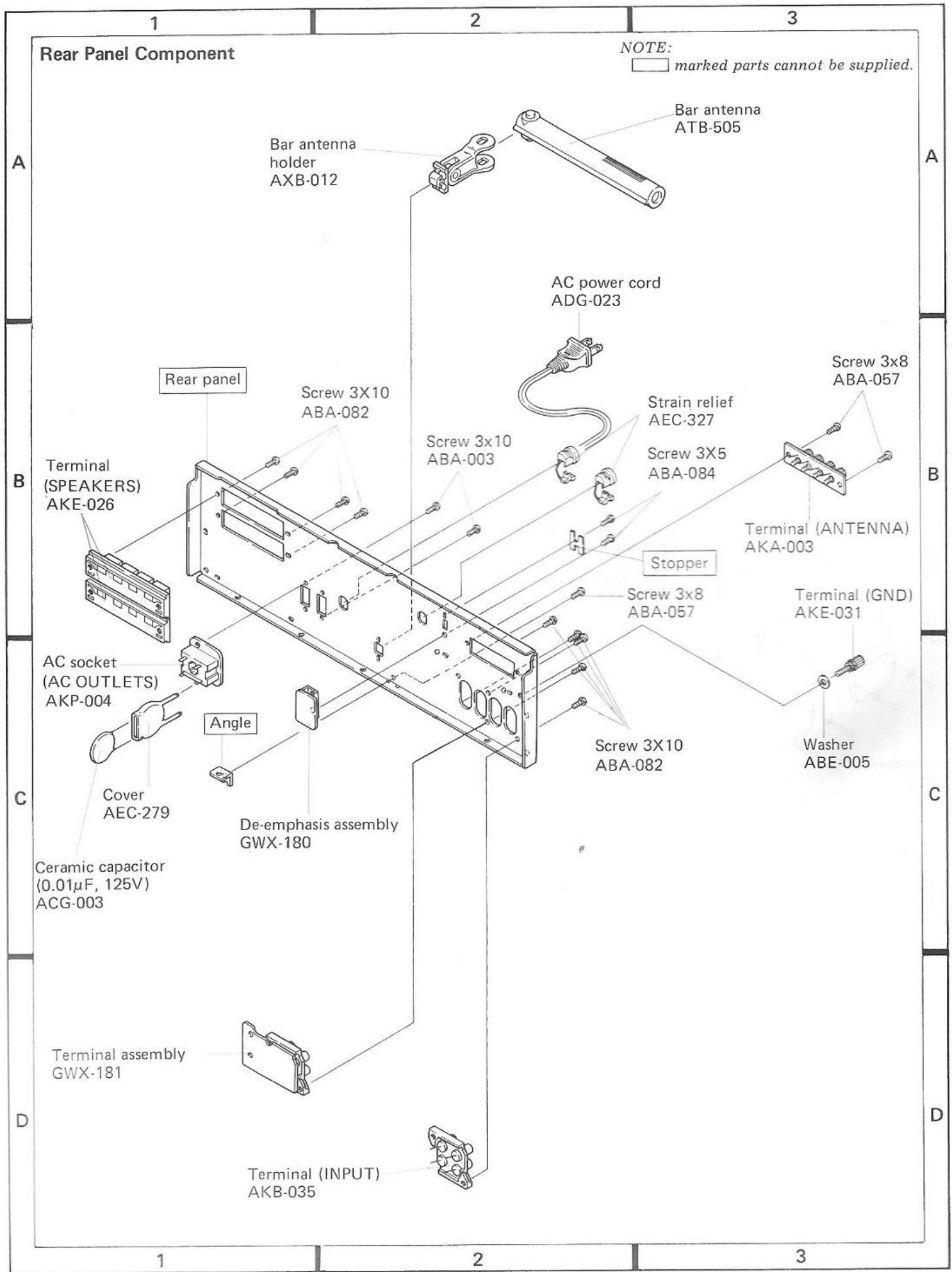

10. PACKING

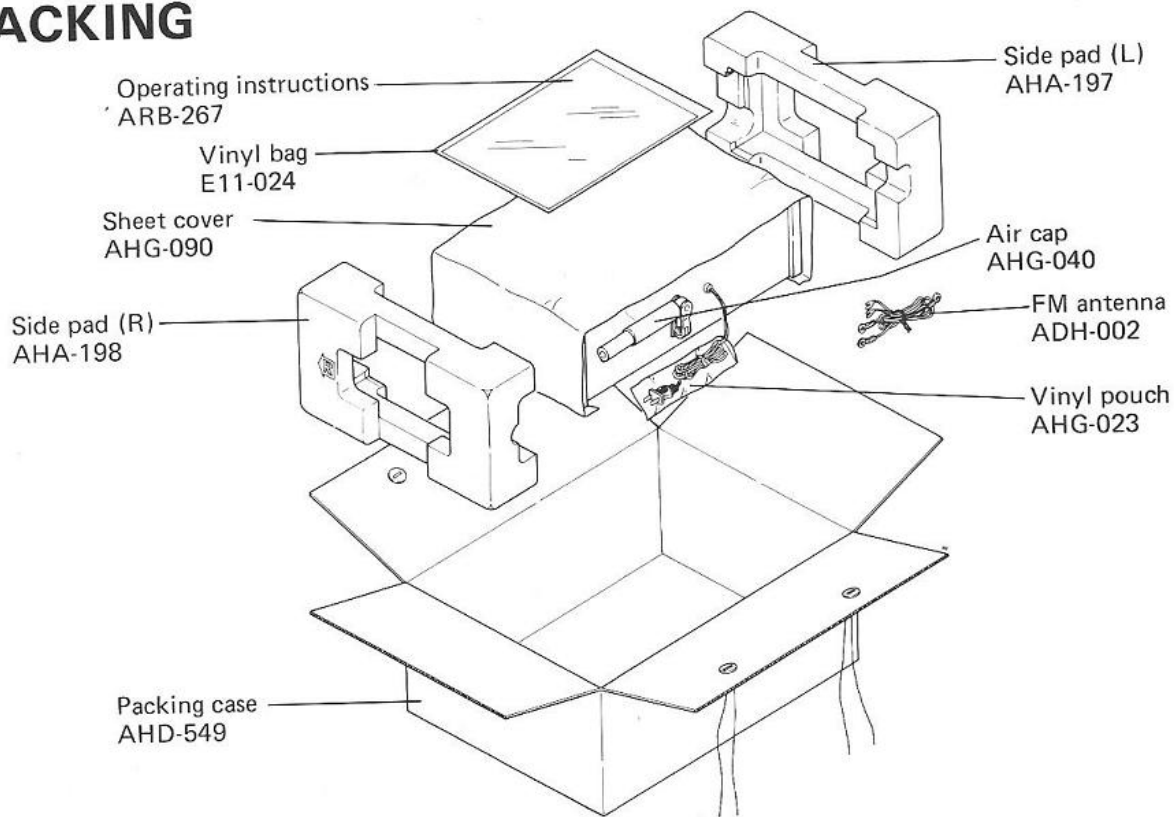

11. SCHEMATIC DIAGRAMS, P.C. BOARD PATTERNS AND PARTS LIST

11.1 MISCELLANEA

NOTE:

When ordering resistors, first covert resistance values into code form as shown in the following examples.

Ex. 1 When there are 2 effective digits (any digit apart from 0), such as 560 ohm and 47k ohm (tolerance is shown by J = 5%, and K = 10%).

560Ω 56 × 10¹ 561 RD¼PS 561 J
 47kΩ 47 × 10³ 473 RD¼PS 473 J
 0.5Ω 0R5 RN2H 0R5 K
 1Ω 010 RSIP 010 K

Ex. 2 When there are 3 effective digits (such as in high precision metal film resistors).

5.62kΩ 562 × 10¹ 5621 RN¼SR 5621 F

Miscellaneous Parts

CAPACITORS

Part No.	Symbol & Description
ACG-001	C1 Ceramic 0.01/250V
ACG-003	C2 Ceramic 0.01/125V

LAMPS AND FUSES

Part No.	Symbol & Description
AEL-029	PL1-PL3 Lamp (wedge type, 8V 0.3A)
AEK-101	FU1 Fuse 3A
AEK-104	FU2 Fuse 1.5A
AEK-100	FU3, FU4 Fuse 4A

SEMICONDUCTORS

Part No.	Symbol & Description
STK-0029	Q1, Q2

P.C. BOARD ASSEMBLIES

Part No.	Description
GWM-113	Tuner and AF assembly
GWX-179	Headphone assembly
GWX-180	De-emphasis assembly
GWB-101	Front-end
GWX-181	Terminal assembly
GWX-178	Fuse assembly
GWX-177	LED assembly

OTHERS

Part No.	Symbol & Description
ATT-510	T1 Power transformer
ATB-505	T2 Bar antenna
ASG-503	S8 Push switch (POWER)
AAW-089	AM-FM meter
AAW-090	Power meter
AKA-003	Terminal (ANTENNA)
AKE-031	Terminal (GND)
AKE-026	Terminal (SPEAKERS)
AKB-035	Terminal (INPUT)
AKP-004	AC socket
AKK-005	Lamp socket
ADG-023	AC power cord

List of changed parts information will be furnished whenever necessary and you are requested to amend parts number in this parts list.

List of Changed Parts for Factory Modification

Symbol	Part No.	Description

Block Diagram of ICs

PA1001-A

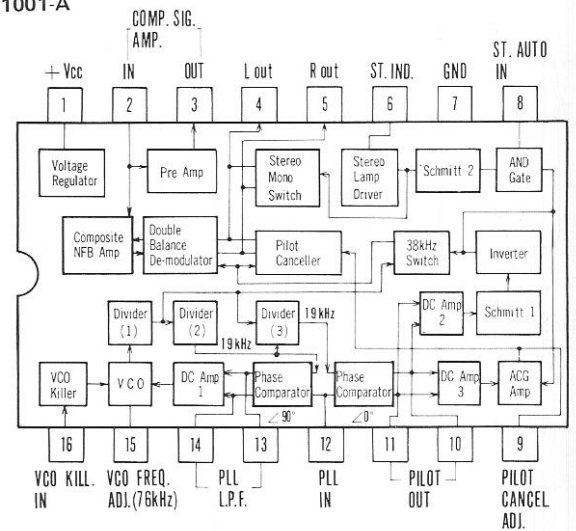

PA3001-A

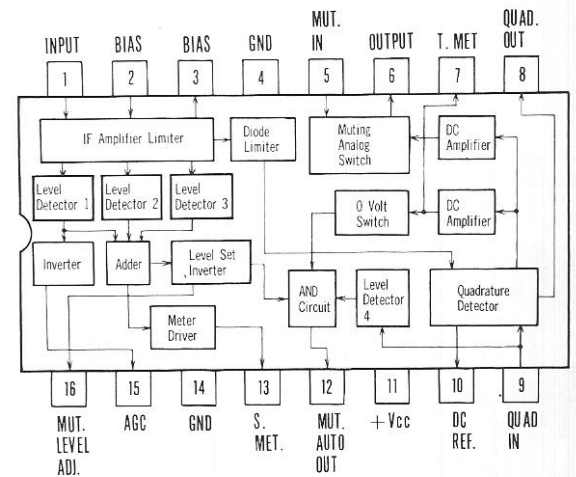

HA1197

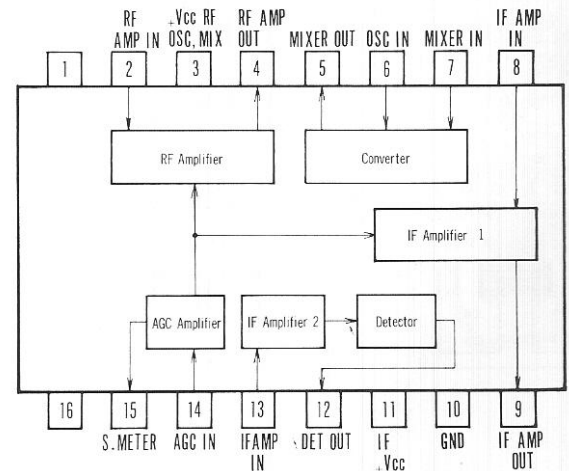

11.2 SCHEMATIC DIAGRAM

A

B

C

D

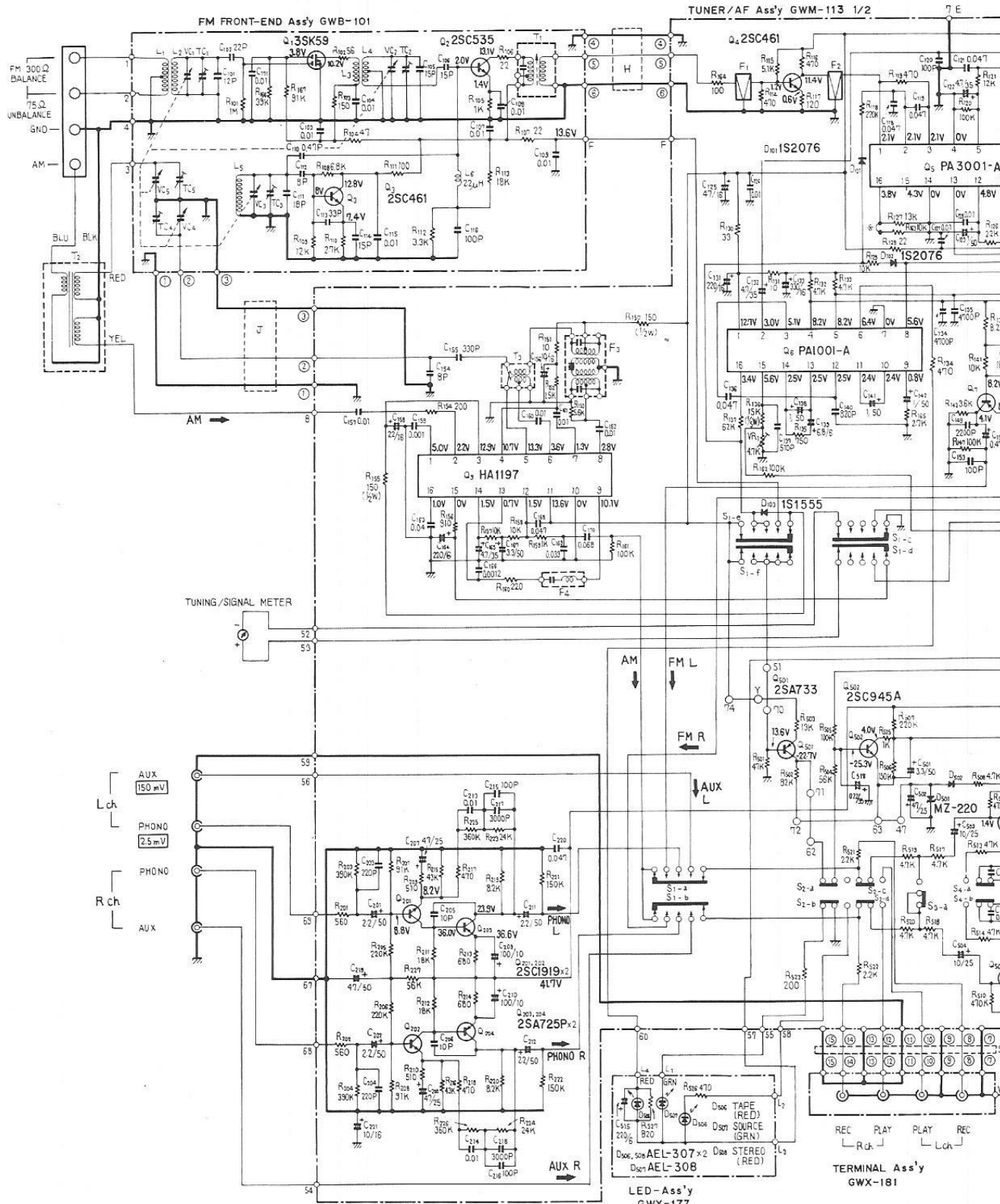

NOTE:
 The indicated semiconductors are representative ones only.
 Other alternative semiconductors may be used and are listed in the parts list.

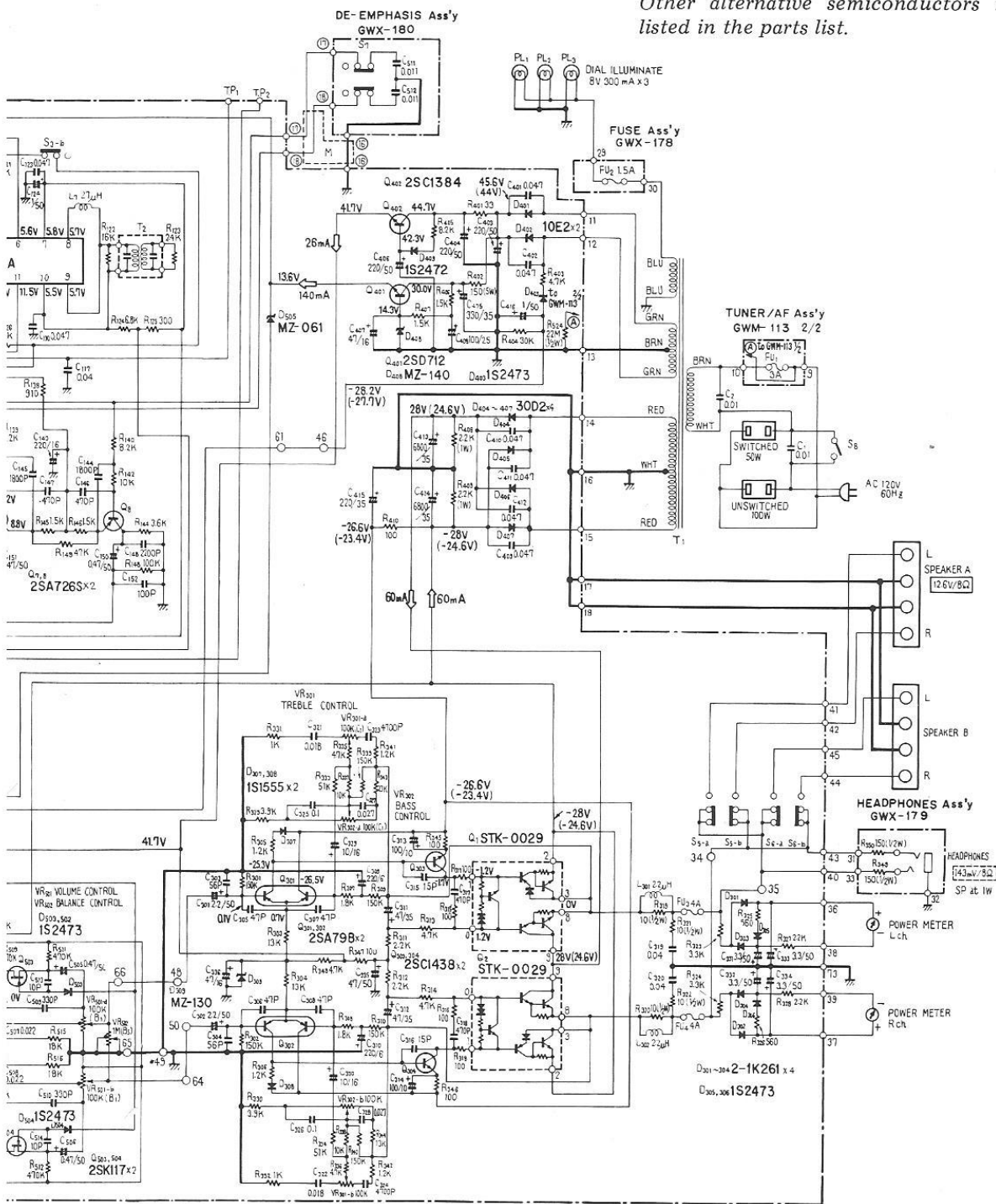

- SWITCHES:**
- S₁: FUNCTION
 - 1. AM
 - 2. FM
 - 3. PHONO
 - 4. AUX
 - S₂: TAPE MONITOR OFF - ON
 - S₃: FM MUTE / MODE ON / STEREO - OFF / MONO
 - S₄: LOUDNESS OFF - ON
 - S₅: SPEAKER A OFF - ON
 - S₆: SPEAKER B OFF - ON
 - S₇: DE-EMPHASIS 75μs - 25μs
 - S₈: POWER OFF - ON

- RESISTORS:**
 IN OHM 1/4W ±5% TOLERANCE UNLESS OTHERWISE NOTED K:KΩ M:MΩ
- CAPACITORS:**
 IN μF UNLESS OTHERWISE NOTED P:pF
- V : SIGNAL VOLTAGE AT 20W + 20W 8Ω OUTPUT (1kHz)
 V : DC VOLTAGE AT NO INPUT SIGNAL
 mA : DC CURRENT AT NO INPUT SIGNAL
 (V) : DC VOLTAGE AT 20W OUTPUT

This is the basic schematic diagram, but the actual circuit may vary due to improvements in design.

A

B

C

D

11.3 P.C. BOARD CONNECTION DIAGRAM

A

FRONT-END (GWB-101)

BALANCE
FM
75Ω
UNBALANCE

GND

AM

B

BLU BLK

T₂

RED

YEL

C

TERMINAL ASSEMBLY (GWX-181)

PLAY REC

D

LED ASSEMBLY (GWX-177)

AEL-507

D508

C515

220/6

R527 820

R526 470

AEL-308

D507

AEL-307

D506

AUX 150mV
L. CH.
PHONO 2.5mV
PHONO
R. CH.
AUX

DE-EMPHASIS ASSEMBLY

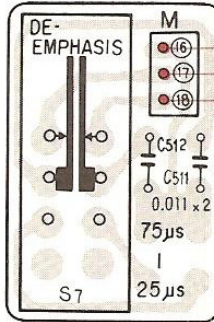

TUNER AND AF ASSEMBLY (GWM-113)

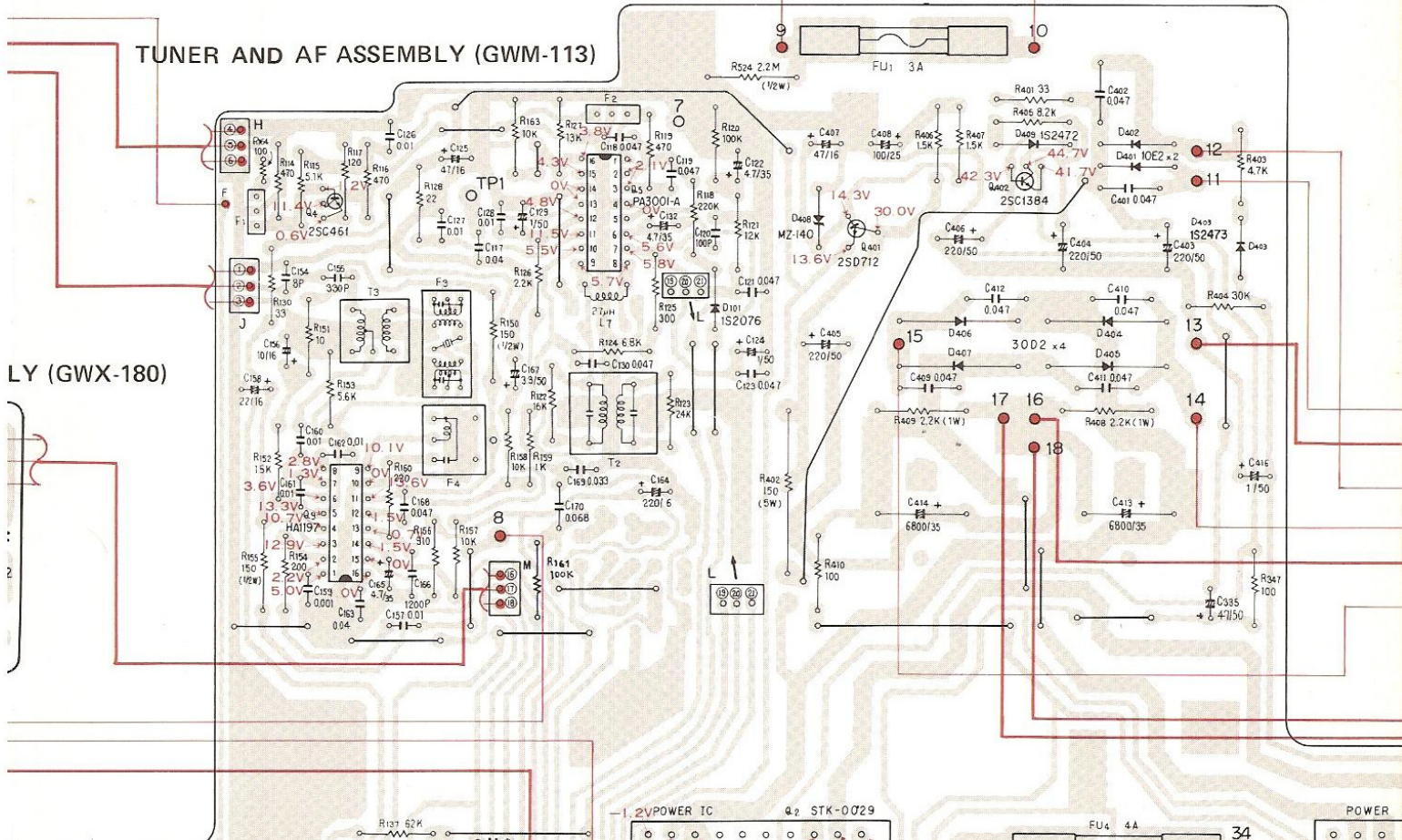

LY (GWX-180)

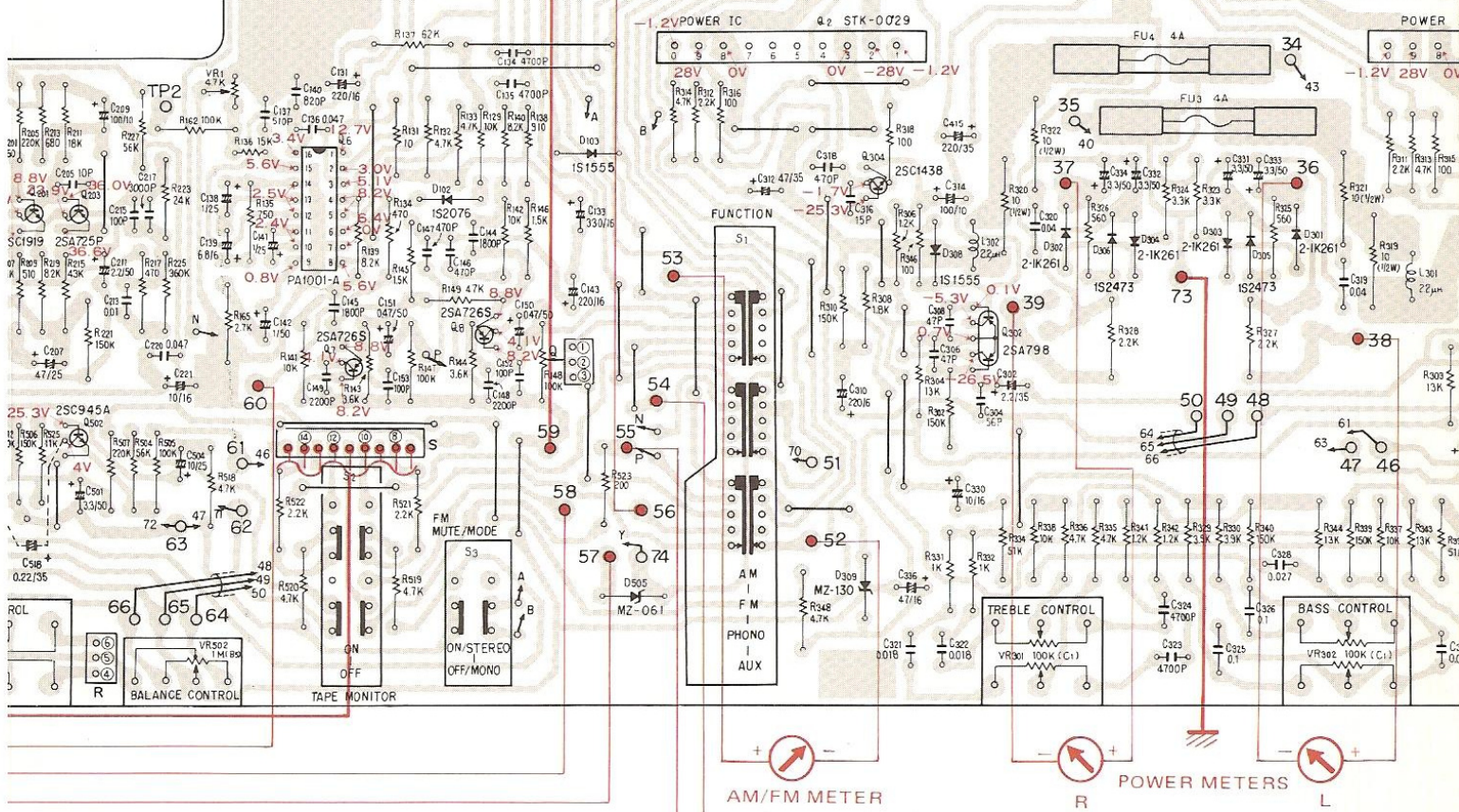

FUSE ASSEMBLY (GWX-178)

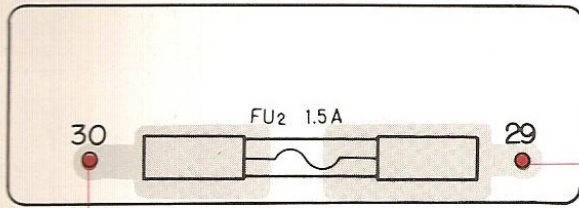

DIAL ILLUMINATE
8V 300mA x 3

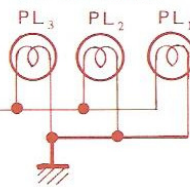

External Appearance of Transistors and ICs

2SC1919
2SA726S



2SA798

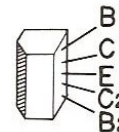

2SC535
2SC461

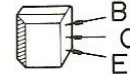

2SA733
2SC1438

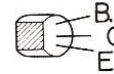

2SC1384

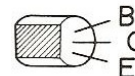

2SK117

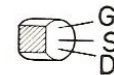

3SK59

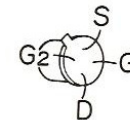

PA3001-A
PA1001-A
HA1197

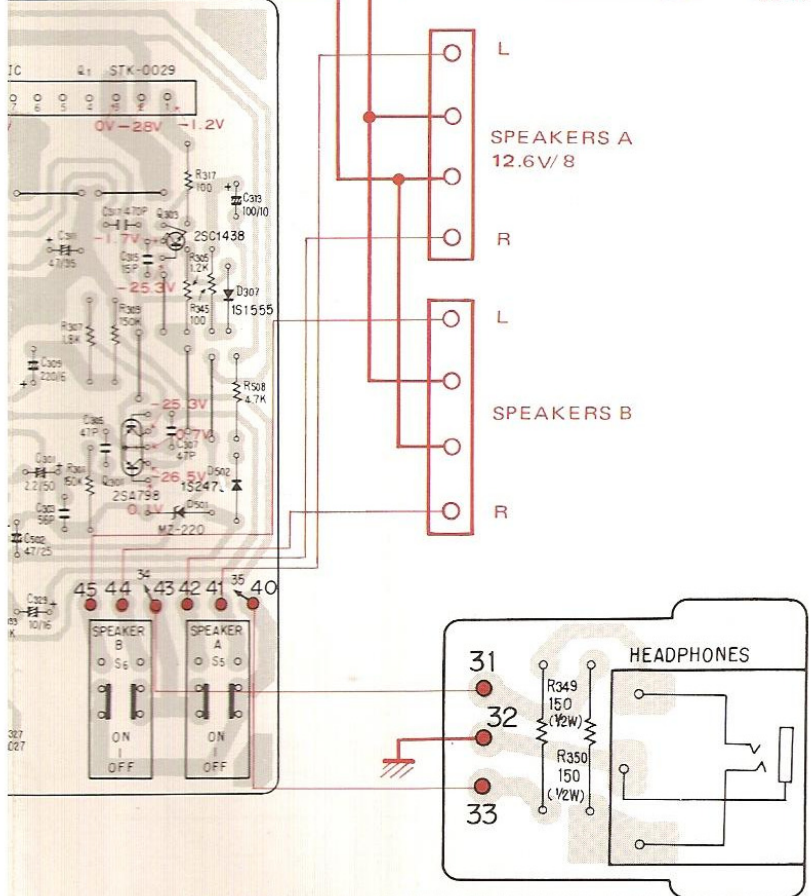
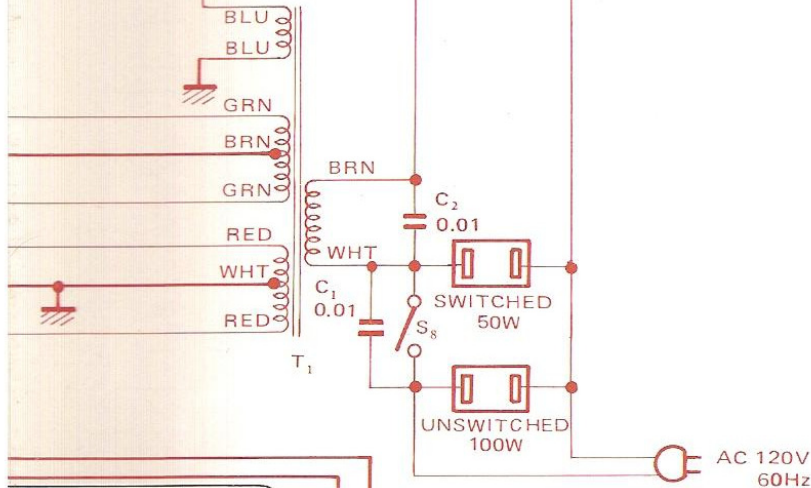
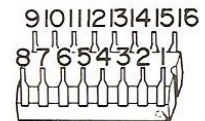

HEADPHONE ASSEMBLY (GWX-179)

A
B
C
D

11.4 FRONT-END (GWB-101)

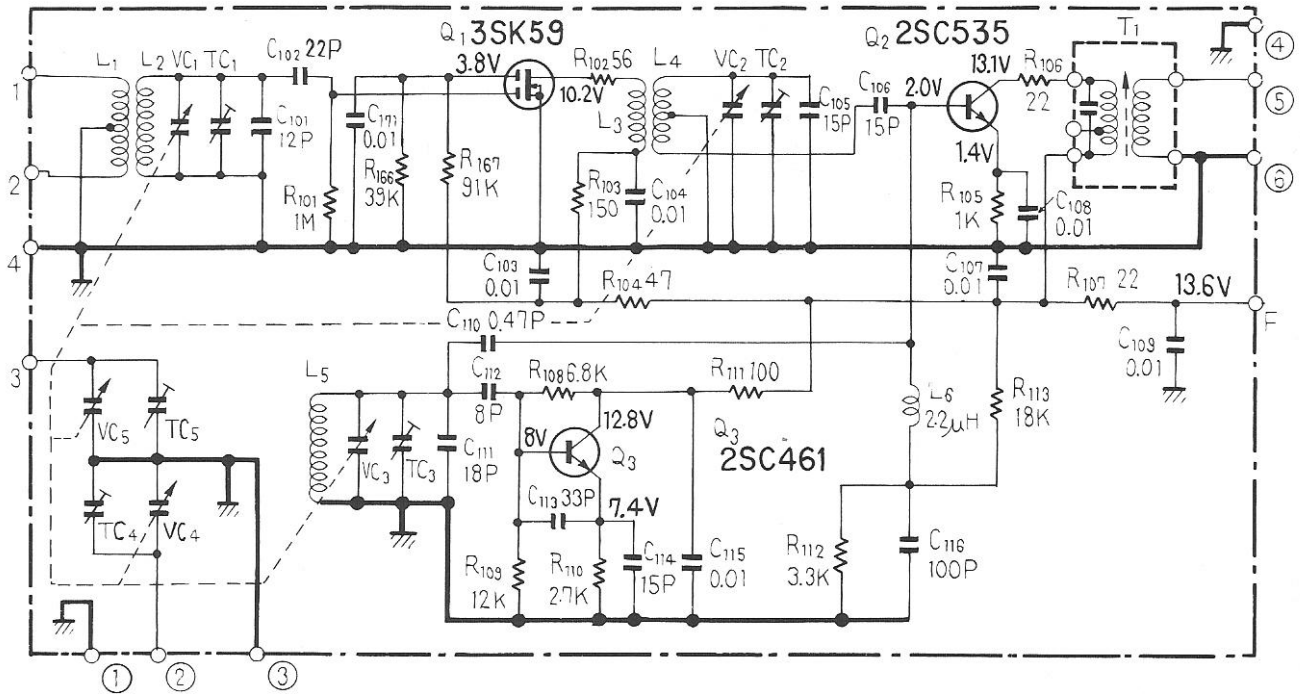

Parts List of Front-end (GWB-101)

SEMICONDUCTORS

Part No.	Symbol & Description
3SK59-Y or GR	Q1
2SC535-A or B	Q2
2SC461-B or C	Q3

TRANSFORMER AND COIL

Part No.	Symbol & Description
ATE-039	T1 FM IF transformer
T24-028	L6 RF choke coil 2.2 μ H

Note: When ordering resistors, convert the resistance value into code form, and then rewrite the part no. as before.

RESISTORS

Part No.	Symbol & Description
RD $\frac{1}{4}$ PS $\square\square\square$ J	R101, R103-R107, R113, R166, R167
RD $\frac{1}{4}$ VS $\square\square\square$ J	R111, R102, R108-R110

CAPACITORS

Part No.	Symbol & Description
CCDUJ 120K 50	C101
CCDSL 220K 50	C102
CKDYF 103Z 50	C103, C104, C107-C109, C115, C171
CCDUJ 150K 50	C105
CCDSL 150K 50	C106
CGB R47K 500	C110
CCDPH 180K 50	C111
CCDLH 080F 50	C112
CCDCH 330K 50	C113
CCDCH 150K 50	C114
CCDSL 101K 50	C116

ACK-012	VC	Tuning capacitor
ACM-006	TC3	Ceramic trimmer

11.5 TERMINAL ASSEMBLY (GWX-181)

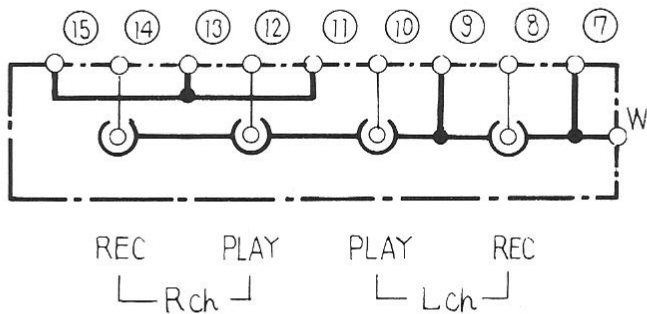

Part No.	Symbol & Description
AKB-045	Terminal (TAPE)

11.6 DE-EMPHASIS ASSEMBLY (GWX-180)

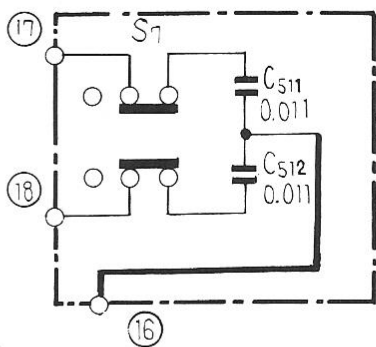

Part No.	Symbol & Description
CQMA 113J 50	C511, C512
ASH-015	S7 Slide switch (DE-EMPHASIS)

11.7 LED ASSEMBLY (GWX-177)

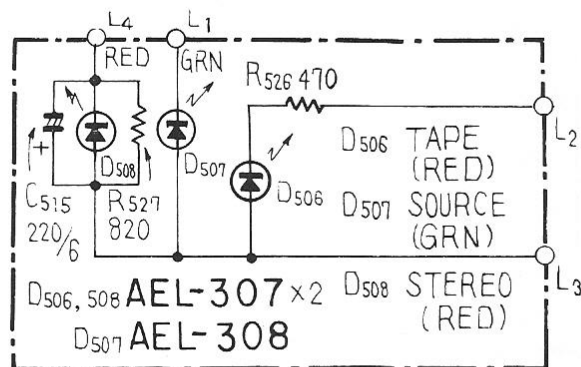

Part No.	Symbol & Description
AEL-308	D507 LED
AEL-307	D506, D508 LED
RD½PS 471J	R526
RD½PS 821J	R527
CEB 221P 6	C515

11.8 HEADPHONE ASSEMBLY (GWX-179)

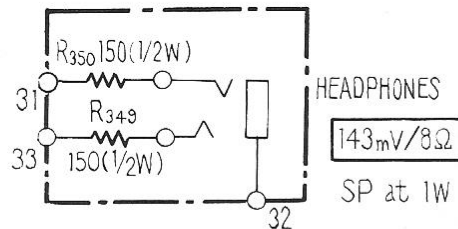

Part No.	Symbol & Description
RD½PS 151J	R349, R350
AKN-009	Phone jack

11.9 FUSE ASSEMBLY (GWX-178)

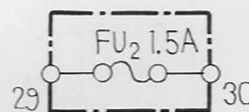

Part No.	Symbol & Description
AKR-013	Fuse clip

11.10 TUNER AND AF ASSEMBLY (GWM-113)

A

B

C

D

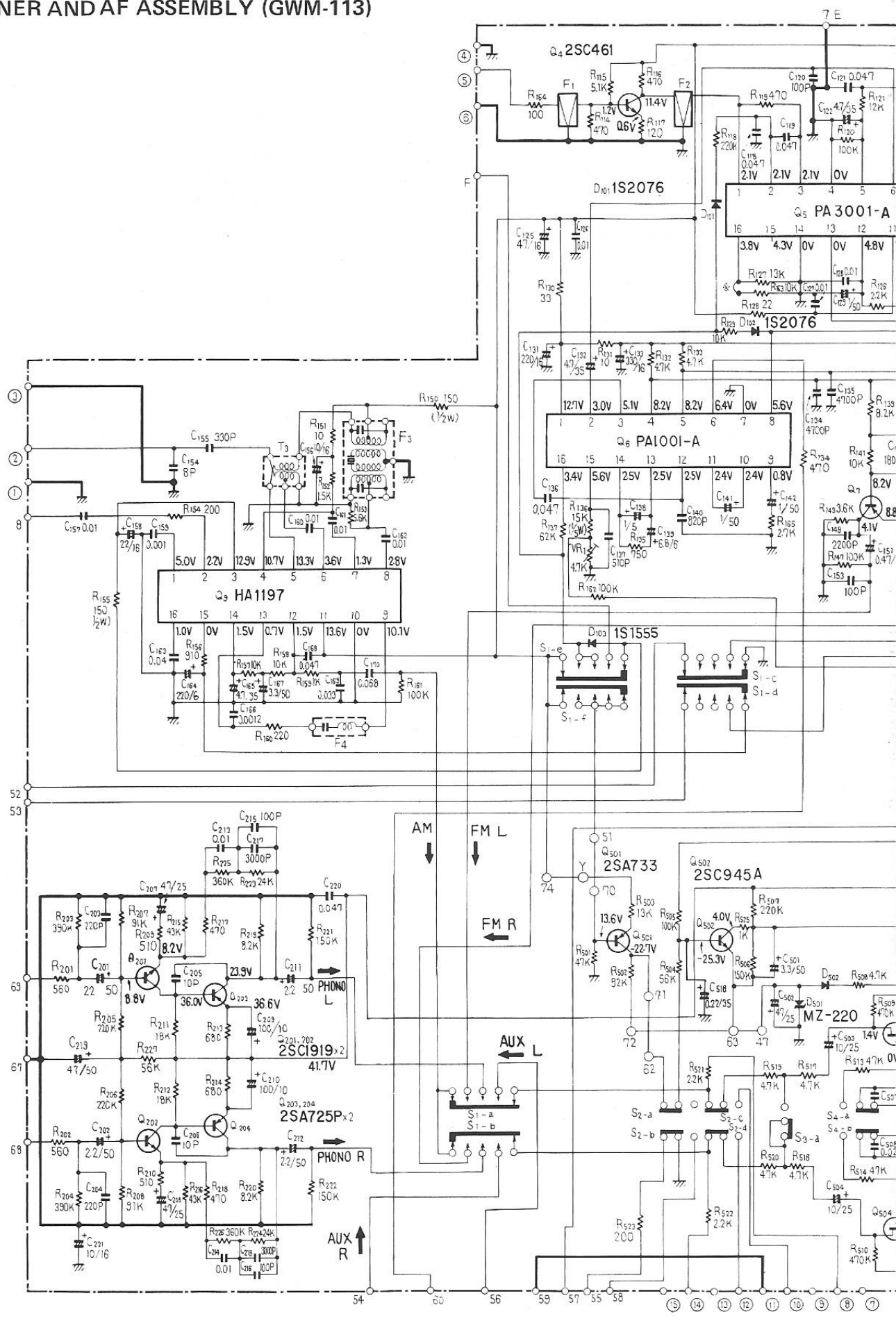

1

2

3

Parts List of Tuner and AF assembly (GWM-113)

SWITCHES

Part No.	Symbol & Description
ASE-107	S1 Slide rotary (FUNCTION)
ASG-137	S2, S3 Dual push (TAPE MON., MODE/FM MUTE)
ASG-138	S4 Push (LOUDNESS)
ASG-139	S5, S6 Dual push (SPEAKERS)

TRANSFORMERS AND COILS

Part No.	Symbol & Description
ATE-040	T2 FM transformer
ATB-013	T3 AM OSC coil
ATF-013	F1, F2 FM ceramic filter
ATF-034	F3 AM ceramic filter
ATF-038	F4 455kHz filter
ATH-022	L7 RF choke coil 27μH

CAPACITORS

Part No.	Symbol & Description
CKDYF 403Z 50	C117, C163
CKDYF 473Z 50	C118, C119, C123, C130, C168
CCDSL 101K 50	C120, C152, C153
CEA 4R7P 16	C122, C132, C165
CEA 010P 50	C124, C129, C142
CEA 470P 16	C125
CKDYF 103Z 50	C126—C128, C157, C160—C162
CEA 221P 16	C131, C143
CEA 331P 16	C133
CQMA 472J 50	C134, C135
CQMA 473K 50	C136
CQSH 511J 50	C137
CEANL 010M 50	C138, C141
CSZA 6R8M 6	C139
CKDYB 821K 50	C140
CKDYB 182K 50	C144, C145
CKDYB 471K 50	C146, C147
CKDYB 222K 50	C148, C149
CEA R47P 50	C150, C151
CCDXL 080F 50	C154
CQSH 331J 50	C155
CEA 100P 16	C156
CEA 220P 16	C158
CKDYB 102K 50	C159
CKDYB 122K 50	C166
CEA 3R3P 50	C167
CQMA 333K 50	C169
CQMA 683K 50	C170
CEA 221P 6	C164

Part No.	Symbol & Description
CEANL 2R2P 50	C201, C202, C211, C212
CCDSL 221K 50	C203, C204
CCDSL 100F 50	C205, C206
CEANL 470P 25	C207, C208
CEA 101P 10	C209, C210
CKDYA 103J 50	C213, C214
(CQMA 103J 50)	
CCDSL 101K 50	C215, C216
CKDYA 302J 50	C217, C218
(CQMA 302J 50)	
CEA 470P 50	C219
CKDYF 473Z 50	C220
CEANL 2R2P 50	C301, C302
CCDSL 560K 50	C303, C304
CCDSL 470K 50	C305—C308
CEA 220P 6	C309, C310
CEA 470P 35	C311, C312
CEA 101P 10	C313, C314
CCDSL 150K 50	C315, C316
CCDSL 471K 50	C317, C318
CCDYF 403Z 50	C319, C320
CQMA 183J 50	C321, C322
CEANL 100P 16	C329, C330
CEA 3R3P 50	C331—C334
CEA 470P 50	C335
CEA 470P 16	C336
ACG-009	C401, C402, C409—412 Ceramic 0.047/150V
CEA 221P 50	C403, C404, C406
CEA 470P 16	C407
CEA 101P 25	C408
ACH-201	C413, C414 Electrolytic 6800/35V
CEA 221P 35	C415
CEA 331P 35	C405
CEA 010P 50	C416
CEA 3R3P 50	C501
CEA 470P 25	C502
CEANL 100P 25	C503, C504
CEANL R47M 50	C505, C506
CQMA 223J 50	C507, C508
CCDSL 331K 50	C509, C510
CCDSL 100K 50	C513, C514
CSZA R22M 35	C518

Note: When ordering resistors, convert the resistance value into code form, and then rewrite the part no. as before.

RESISTORS

Part No.	Symbol & Description
RD½PS □□□ J	R114—R135, R137—R149, R151—R154, R156—R163
RD¼PS □□□ J	R201—R204, R209—R227
RD¼PS □□□ J	R301—R318, R323—R348
RD¼PS □□□ J	R403—R407
RF¼PS □□□ J	R401, R410
RD¼PS □□□ J	R501—R523, R525
RD¼PS □□□ JNL	R205—R208

PIONEER ELECTRONIC CORPORATION 4-1, Meguro 1-Chome, Meguro-ku, Tokyo 153, Japan
U.S. PIONEER ELECTRONICS CORPORATION 85 Oxford Drive, Moonachie, New Jersey 07074, U.S.A.
PIONEER ELECTRONIC (EUROPE) N.V. Luithagen-Haven 9, 2030 Antwerp, Belgium
PIONEER ELECTRONICS AUSTRALIA PTY. LTD. 178-184 Boundary Road, Braeside, Victoria 3195, Australia