

AM/FM STEREO TUNER

TX-9500II

SERVICE MANUAL



 PIONEER®

MODEL TX-9500II COMES IN FOUR VERSIONS DISTINGUISHED AS FOLLOWS:

Type	Voltage	Remarks
KC	120V only	CSA (Canada) approved with de-emphasis selector switch (25μs/75μs)
KU	120V only	UL (U.S.A.) approved with de-emphasis selector switch (25μs/75μs)
HG	220V and 240V (Switchable)	SEMKO (Sweden), NEMKO (Norway), DEMKO (Denmark) and EI (Finland) approved
S	110V, 120V, 220V and 240V (Switchable)	General export model with de-emphasis selector switch (25μs/50μs/75μs)

- Service informations for TX-9500II/KU is described on page 5 through 52 in this manual.
- For servicing of KC, S and HG types please refer to TX-9500II/KU manual with the exception of descriptions in the "Additional Service Manual" (p.53–p.86).

CONTENTS

1.	SPECIFICATIONS	5
2.	CONNECTION DIAGRAM	6
3.	FRONT PANEL FACILITIES	7
4.	BLOCK DIAGRAM	9
5.	CIRCUIT DESCRIPTIONS	
5.1	AM Tuner	11
5.2	FM Tuner	11
5.3	REC LEVEL CHECK Signal Generator Circuit	15
5.4	Power Supply Circuit	15
6.	DISASSEMBLY	16
7.	PARTS LOCATION	
7.1	Front Panel View	17
7.2	Front View with Panel Removed	18
7.3	Top View	19
7.4	Rear Panel View	20
8.	DIAL CORD STRINGING	21

9.	ADJUSTMENTS	
9.1	FM Section	22
9.2	AM Section	26
10.	EXPLODED VIEWS	
10.1	Top Side	27
10.2	Bottom Side	29
10.3	Nomenclature of Screws, Washers and Nut	31
11.	PACKING	32
12.	SCHEMATIC DIAGRAMS, P.C. BOARD PATTERNS AND PARTS LIST	
12.1	Schematic Diagram and Miscellaneous Parts List	33
12.2	FM Front End (AWB-023)	36
12.3	AM FM IF Assembly (AWE-070)	37
12.4	MPX AF Assembly (AWD-009)	45
12.5	Power Supply Assembly (AWR-128)	50
Additional Service Manual		
1.	CONTRAST OF MISCELLANEOUS PARTS	54
2.	KC TYPE	
2.1	Schematic Diagram and Miscellaneous Parts List	56
2.2	Power Supply Assembly (AWR-129)	59
2.3	Packing	61
3.	HG TYPE	
3.1	Schematic Diagram and Miscellaneous Parts List	62
3.2	MPX AF Assembly (AWD-008)	65
3.3	Power Supply Assembly (AWR-130)	70
3.4	Packing	73
4.	S TYPE	
4.1	Schematic Diagram and Miscellaneous Parts List	74
4.2	MPX AF Assembly (AWD-010)	77
4.3	Power Supply Assembly (AWR-131)	82
4.4	Switch Assembly (AWX-113)	85
4.5	Packing	86

2. CONNECTION DIAGRAM

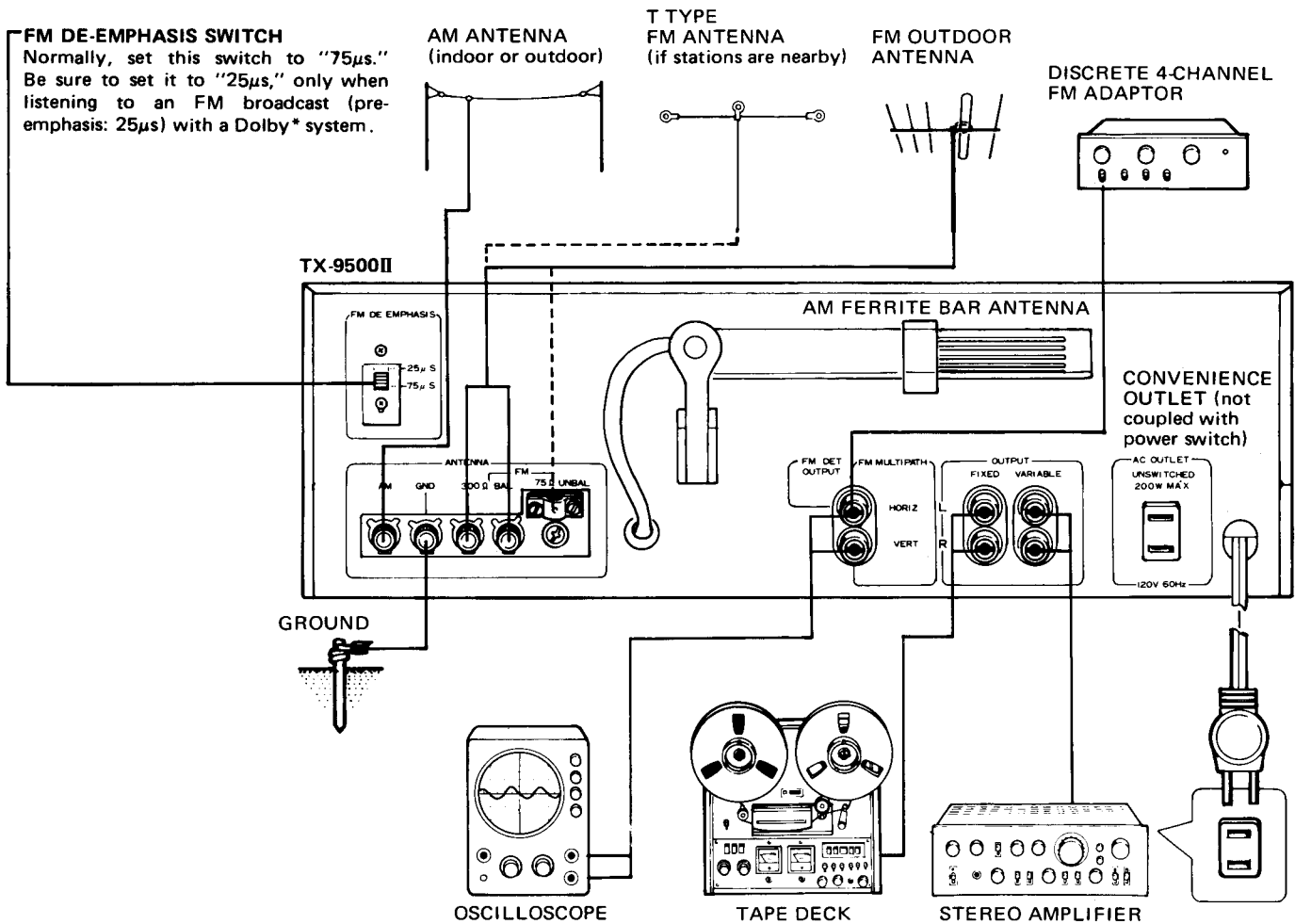

* The word "Dolby" is a trademark of Dolby Laboratories Inc.

3. FRONT PANEL FACILITIES

POWER SWITCH

Set to ON position to turn on power. Pilot lamp will light.

IF BAND SWITCH

FM IF (intermediate frequency) passband can be set to for wide or narrow.

WIDE: Normally set switch to this position.

NARROW: If adjacent station interference is a problem at the WIDE setting, set switch to this position.

MULTIPATH/REC LEVEL CHECK SWITCH

Single lever operates both MULTIPATH and REC LEVEL CHECK switches. With the FUNCTION switch at FM, set as required for the application. Be sure to return it to the OFF position when it is not being used.

MULTIPATH ON: Multipath sound becomes audible from speakers. When installing FM antenna, select antenna location and direction so as to minimize this sound.

OFF: Normally set switch to this position.

REC LEVEL CHECK ON: Use this position for setting recording levels of tape deck. A 440Hz signal (level corresponding to 50% FM modulation) is produced at approximately 1.7 second intervals.

SIGNAL METER

Employ when tuning AM and FM stations. Optimum tuning point occurs when maximum meter deflection toward the right is obtained.

TUNING

Use when deflection tune carefully (optimum)

PILOT LAMP

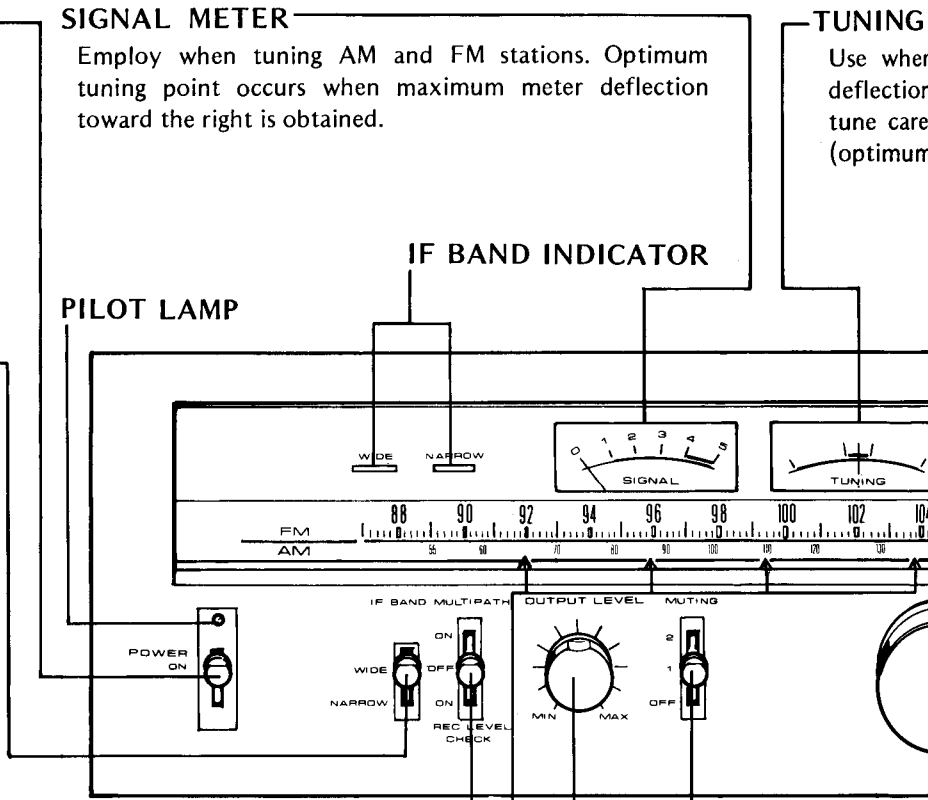

MEMORY MARKERS

Convenient for designating most often tuned in stations. Slide markers with fingertip to desired positions.

OUTPUT LEVEL CONTROL

Adjusts level at OUTPUT (VARIABLE) jacks. Clockwise rotation increases output level.

MUTING

Controls noise when tuning operation:

1:

OFF:

SIGNAL METER
 Optimum deflection

TUNING METER
 Use when tuning FM stations. First tune for maximum deflection of the SIGNAL meter (toward the right), then tune carefully so that the meter indicates center of scale (optimum tuning point).

FM STEREO INDICATOR
 With the FUNCTION switch set to FM AUTO (or FM NOISE FILTER), the indicator will light during stereo signal reception.

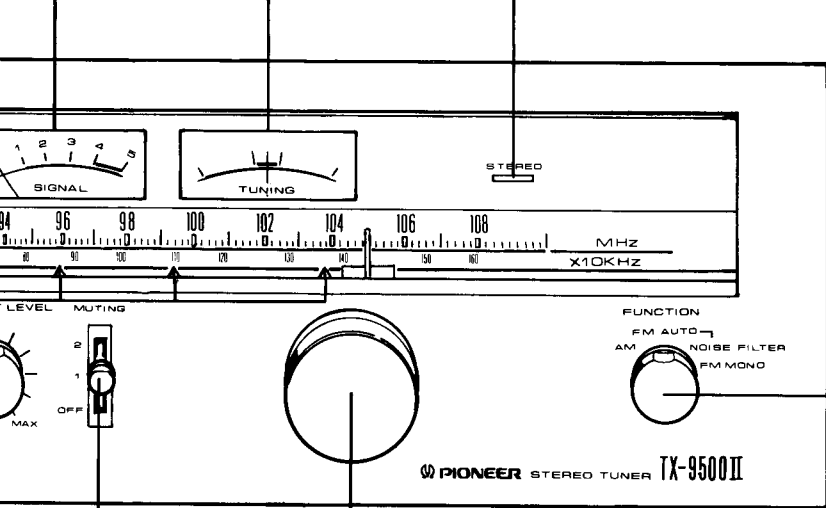

FUNCTION SWITCH
 Switch for selecting type of reception.
 AM: AM broadcast reception.
 FM AUTO: FM stereo reception. If broadcast is FM mono, the mono mode is automatically selected.
 FM NOISE FILTER: Set to this position if comparatively high frequency noise becomes objectionable during FM stereo reception. Note that some loss of stereo separation occurs at this position.
 FM MONO: FM monophonic reception. Set to this position if reception at FM AUTO position is noisy or signals weak.

MUTING SWITCH
 Controls circuit for cancelling bothersome interstation noise when tuning FM stations to provide a comfortable tuning operation.

2: Set to this position to receive only strong stations.
 1: If desired station cannot be received at position 2, set switch to this position.
 OFF: Set to this position in locations where signals are extremely weak.

TUNING KNOB
 Knob for selecting stations. Refer to the SIGNAL meter when tuning AM stations and to both SIGNAL and TUNING meters when tuning FM stations.

in stations.
 s.

Clockwise

4. BLOCK DIAGRAM

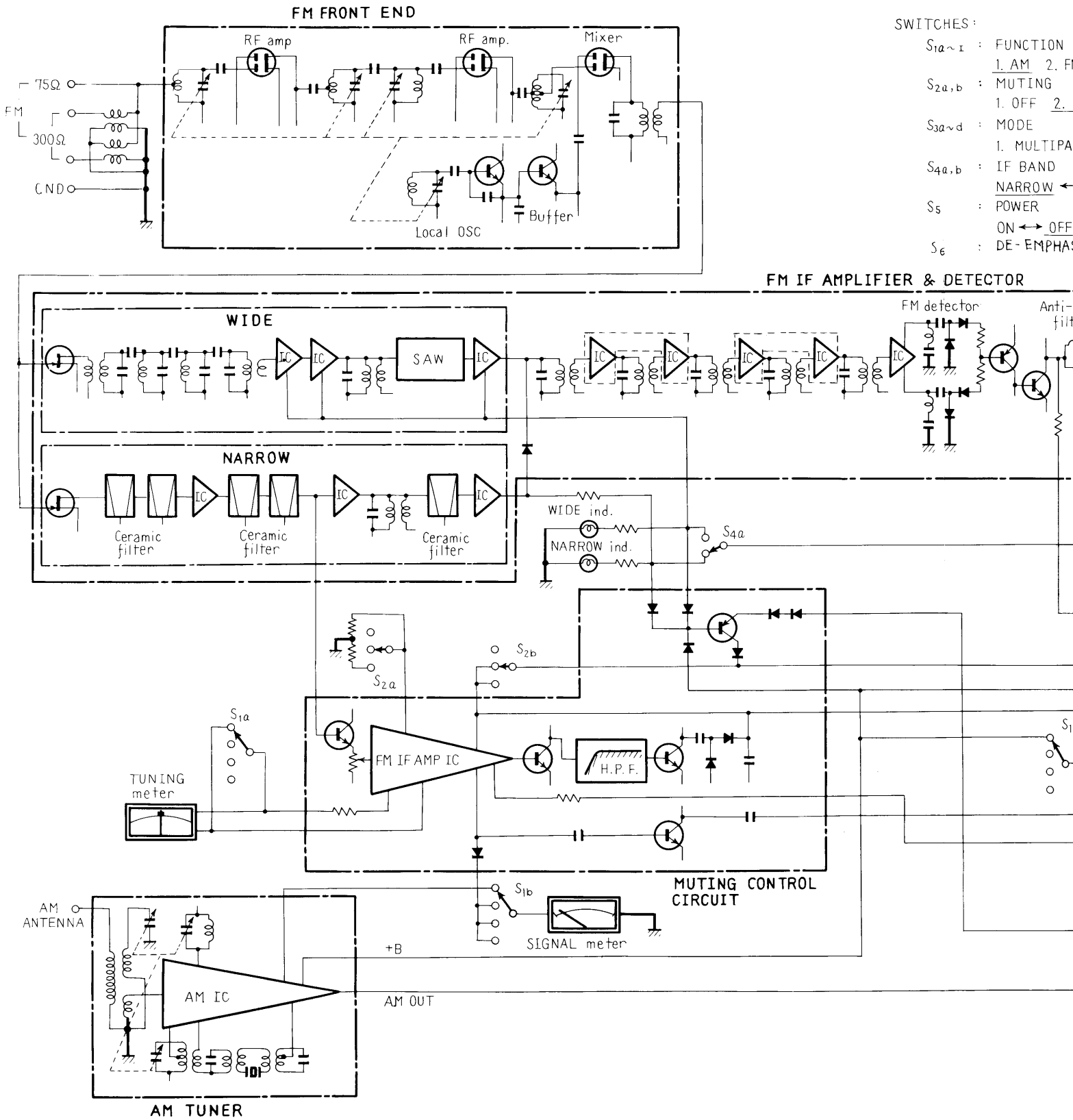

SWITCHES:

- S_{1a~i} : FUNCTION
1. AM 2. FM AUTO 3. FM MPX NOISE FILTER 4. FM MONO
- S_{2a,b} : MUTING
1. OFF 2. 1 3. 2
- S_{3a~d} : MODE
1. MULTIPATH ON 2. OFF 3. REC LEVEL CHECK ON
- S_{4a,b} : IF BAND
NARROW ↔ WIDE
- S₅ : POWER
ON ↔ OFF
- S₆ : DE-EMPHASIS 25μS ↔ 75μS

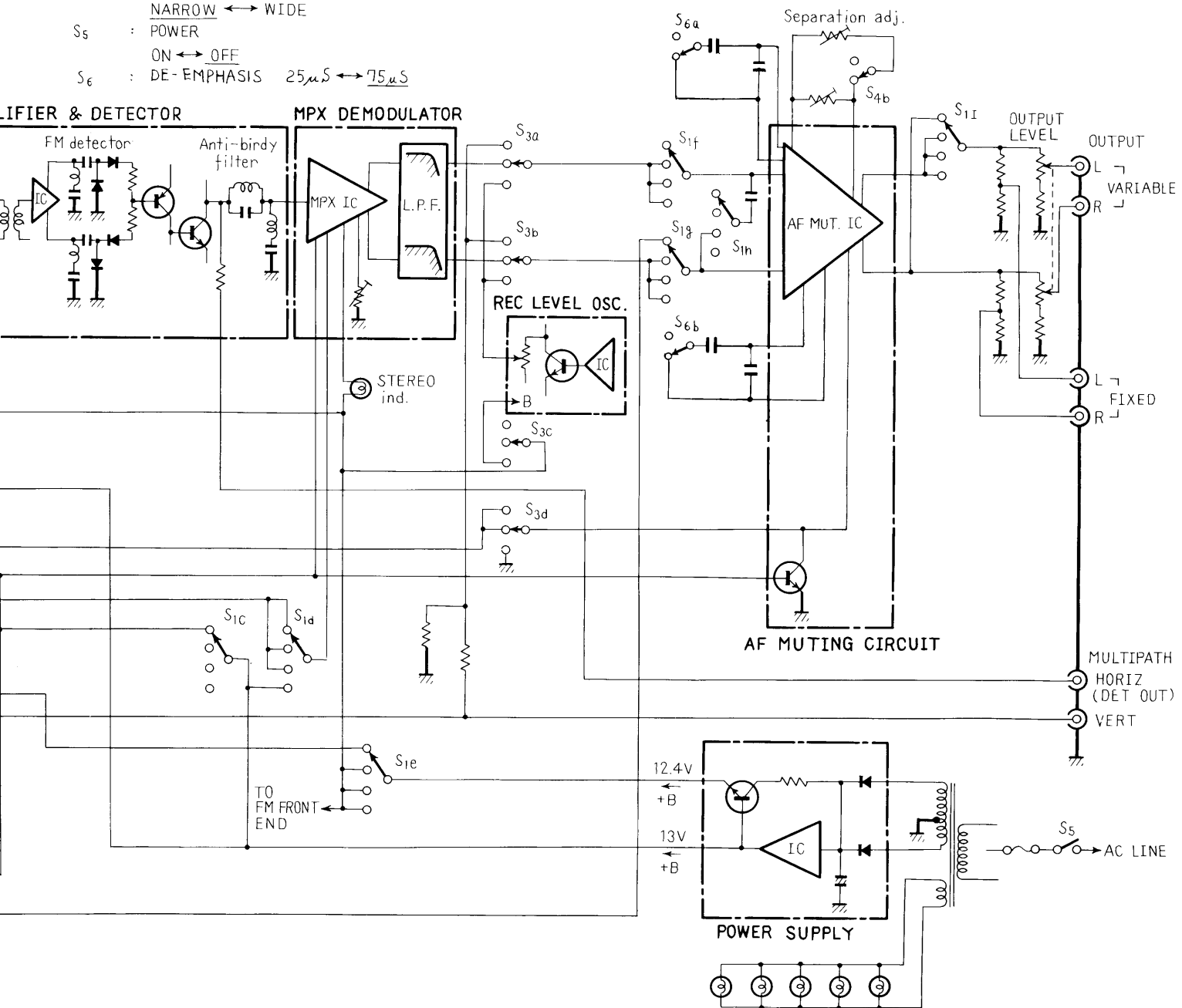

5. CIRCUIT DESCRIPTIONS

5.1 AM TUNER

The major components of the AM tuner are the 3-ganged variable capacitor, a newly developed IC (HA1197), and an AM ceramic filter. A block diagram of the HA1197 is shown in Fig. 1.

This IC consists of an RF amplifier first stage, followed by a mixer stage which also includes a self-oscillating local oscillator, the IF amplifier 3rd and 4th stages, and a detector circuit final stage. The AGC (Automatic Gain Control) receives an AGC voltage from the output of the detector circuit, and applies it to the RF amplifier and IF amplifier stages. The advantage of the HA1197 is a large reduction in the distortion at low frequencies. Whereas the distortion at 100Hz was 1.5% in the previous HA1138, this figure has been reduced to 0.4% (100Hz) in the HA1197.

5.2 FM TUNER

FM Front-end

The FM front end is composed of a tuning circuit employing a 5-gang variable capacitor, a 2-stage RF amplifier a mixer employing dual gate MOS FETs, and a local oscillator with buffer. An equivalent of a cascode amplifier is produced by AC grounding gate-2 of the dual gate MOS FET, allowing stable RF amplification at high gain.

The output signal of the RF amplifier is applied to gate-1 of the mixer stage MOS FET, while the local oscillator output signal is applied to gate-2. This technique minimizes input power from the local oscillator, resulting in low mutual interference even if the received signal input level is high.

A variation of a Clapp circuit forms the local oscillator. Inclusion of a buffer amplifier between local oscillator and mixer reduces local oscillator load, eliminating distortion of the oscillation waveform. Drawing effect of the local oscillator is also eliminated.

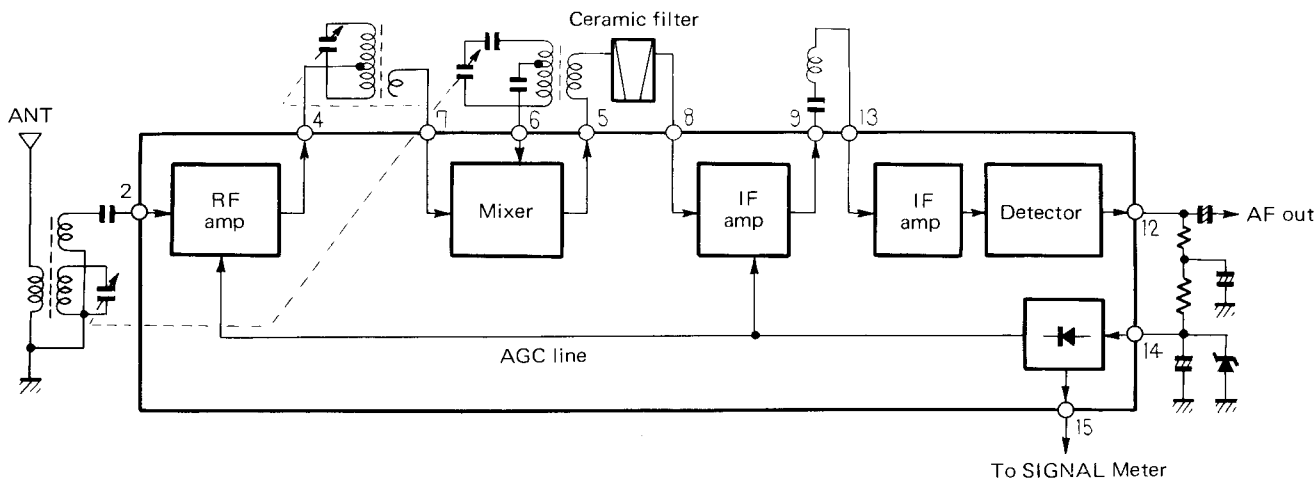

Fig. 1 Block diagram of HA1197

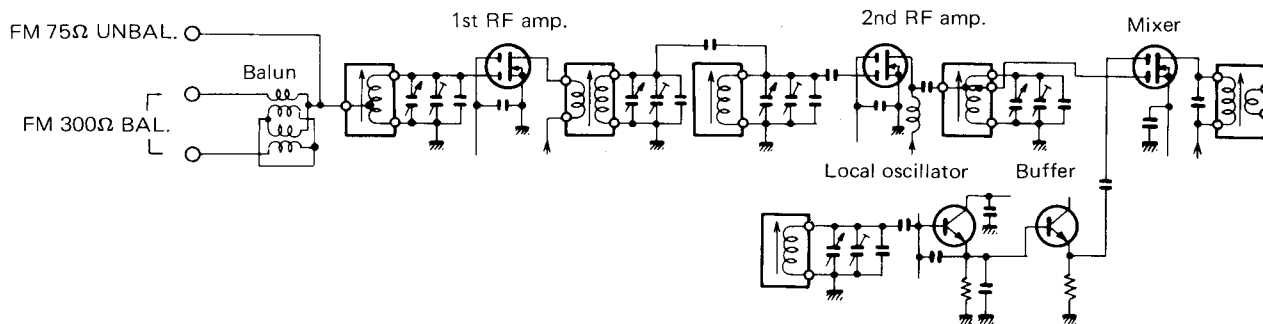

Fig. 2 Circuit of FM front end

FM IF Amplifier

In this FM IF amplifier, there are two selectable IF frequency pass bands, viz. WIDE band and NARROW band, selected by the IF BAND switch.

This circuit is shown in Fig. 3.

The SAW (Surface Acoustic Wave) filter used in the WIDE band circuit, is a filter which works on entirely new principles. Signals are carried across the piezoelectric element surface by mechanical vibrations. The advantages of this SAW filter in comparison with a 2-element ceramic filter, is that the group delay time flatness characteristics cover more than twice (500Hz) the band width while still maintaining the same degree of selectivity.

The tetra-polar phase linear filter makes use of the SAW filter characteristics to further improve the degree of selectivity. Consequently, the WIDE band circuit has been designed with the aim of even further improving the distortion factor.

The NARROW band circuit employs 5 2-element ceramic filters for very good selectivity. This circuit is outstanding in its ability to reject interfering signals, and is particularly suitable for areas where adjacent stations are crowded very close together on the FM band. The distortion factor too, is very close to the value obtained in the WIDE band.

Switching between the WIDE and NARROW bands is accomplished by switching a +B voltage supply ON and OFF. But since the IF amplifier in the NARROW band circuit is the same IF amplifier used to operate the meters and the muting function, the +B voltage supply for the final stage IC and diode (D₁) would also be turned ON and OFF. Switching the +B voltage supply for D₁ ON and OFF will cause D₁ to act as a switch. When the +B voltage is applied to the anode of D₁, D₁ is put into

a conducting state, with the signal passing into the next stage.

Following the IF amplifier in NARROW band, or following the WIDE band circuit there is a 5-stage wide-band IF amplifier which produces sufficient limiter effect.

FM Detector

The detector circuit used in the TX-9500II is a super wide band linear detector circuit, a product resulting from the study of distributed constant type detectors.

The circuit is shown in Fig. 4.

M5109PR included in this circuit is an IC incorporating 2 pairs of differential amplifiers. The loads of each differential amplifier are connected to a series resonance circuit where the L₁₆, C₃₂ resonance frequency is higher than the intermediate frequency (10.7MHz), and the L₁₅, C₃₃ resonance frequency is lower. The IF outputs from each of these differential amplifiers are modulated to the AM components which are then detected by D₃ - D₆.

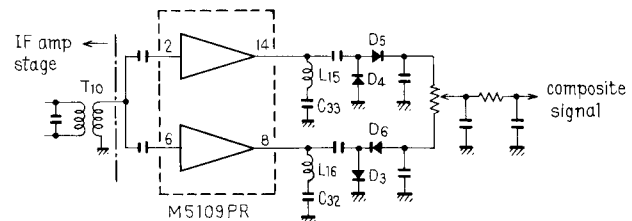

Fig. 4 Circuit of FM detector

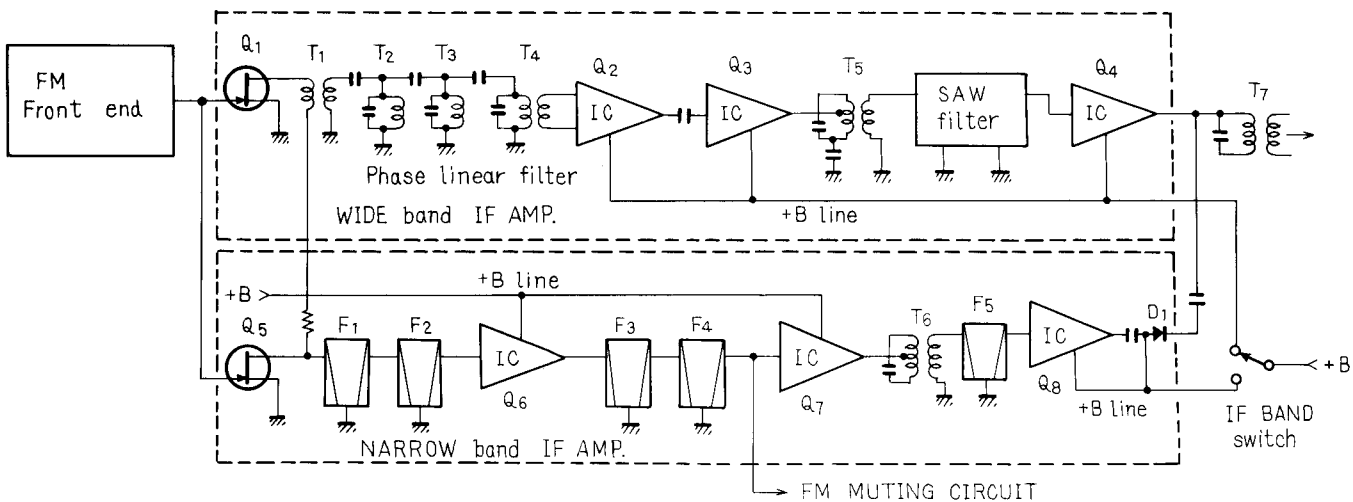

Fig. 3 Circuit of FM IF amplifier

Anti-birdy Filter

The function of this filter is to remove any component signals belonging to adjacent stations within 200kHz of the tuned station which are still contained in the signal after detection. If it were not for this filter, beating in resonance with the 10th and 11th harmonics of the 19kHz pilot signal generated in the MPX IC of the final stage would occur, and appear as noise in the reproduced signal.

FM Multiplex Decoder

This section includes another IC recently developed by Pioneer, the PA1001. See Fig. 5 for the block diagram.

This IC, an improvement over a previous IC (HA1196), incorporates a pilot auto-canceller circuit. This circuit filters out the leak carrier (19kHz) contained in the demodulated signal without any loss in the frequency characteristics of the audio signal. This filtering action is a considerable improvement over the previous low pass filter method. Other features include a wider input dynamic range, and the ability to perform well even when a 300% modulated input signal is applied to the IC. S/N ratio and distortion factor have also been improved by the incorporation of a NFB circuit in the decoder amplifier. Distortion has also been improved in the case of MONO signals by connecting together the output circuits of the L and R channels, and thus cancelling the out-of-phase distortion components contained in the L and R channel audio signals.

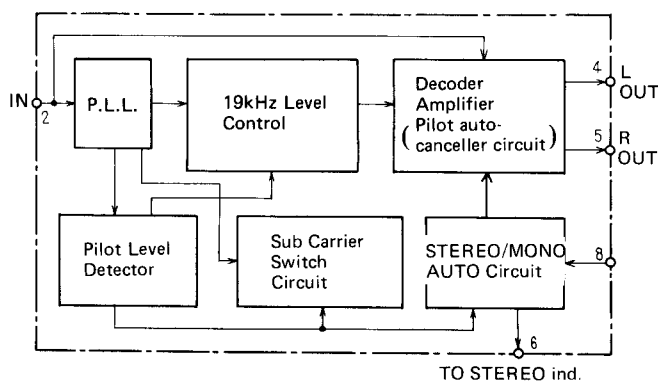

Fig. 5 Block diagram of PA1001

AF Amplifier and Muting

This circuit employs the Pioneer developed IC (PA1002). The block diagram is shown in Fig. 6.

This AF amplifier is a direct coupled amplifier used as a differential NFB amplifier providing

outstanding dynamic range, S/N ratio, and distortion factor. De-emphasis is provided by inserting a time constant circuit in the NFB loop of the AF amplifier. The elements in this time constant circuit include a metal film resistor (1% tolerance) and a polystyrene film capacitor (2% tolerance) which have made it possible to reduce de-emphasis deviation to within +0.2dB to -0.5dB in the 20Hz to 15kHz range.

The switching circuit for the muting function is activated when a DC voltage from the power ON/OFF detector section or from terminal no.8, is received. The signal circuit is then connected to ground, thus preventing the output of any signals. This power ON/OFF detector circuit detects the instantaneous change when the POWER switch is turned ON or OFF, sending a trigger signal to the switching circuit, and thus activating the muting function. As a result, the popping noise usually generated when the POWER switch is turned ON or OFF, plus the residual noise, is eliminated.

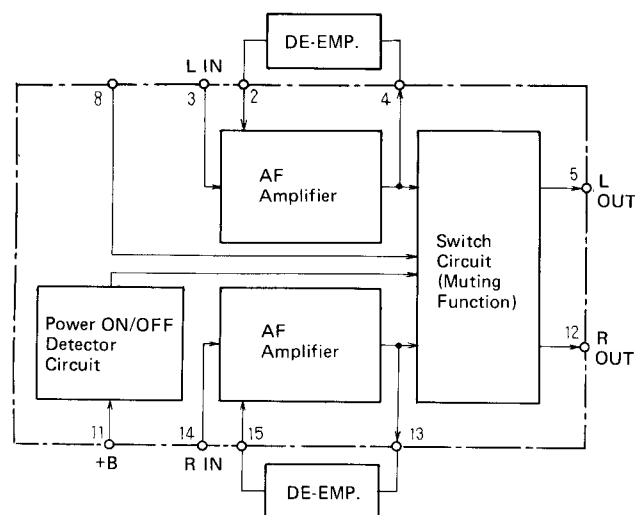

Fig. 6 Block diagram of PA1002

FM Control Circuit

The FM control circuit used to control the meter drive and FM muting circuits, is independent of the audio signal circuitry. This circuit, too, incorporates an IC (PA3001) recently developed by Pioneer. The block diagram is shown in Fig. 8.

The PA3001 is very similar to the previous IC (HA1137) in function and operation. It differs in that the FM muting level can be controlled external to the IC. The input signal is supplied by the IF amplifier in NARROW band (See Fig. 7).

The FM muting function in the TX-9500II works in 5 different ways:

1. Muting of the noise contained in the received signal.
2. Muting at a specific antenna input level.
3. Muting when not tuned to any station.
4. Muting when the IF BAND switch is switched.
5. Muting when the FUNCTION switch is switched.

The disconnection of the signal circuitry during all of the above mentioned muting actions, is performed by means of a switch circuit incorporated inside the PA1002 IC.

1. Muting of the noise contained in the received signal

Detection of this noise component is performed in the NOISE amplifier (Q_{17} , high pass filter, Q_{18}) shown in Fig. 7. After detection, the audio signal appears at terminal no.6 of PA3001, with the noise components above 100kHz contained within this audio signal being detected and amplified by the NOISE amplifier. The output of this NOISE amplifier (noise component) is rectified at D_{13} and D_{14} , and then removed as a DC voltage.

This DC voltage is passed via S_{2-b} (MUTING switch) and S_3 (MODE switch), finally being applied to terminal no.8 of PA1002. When the audio signal contains a high level of high frequency noise, the PA1002 switch circuit is activated, resulting in the signal circuit being shorted to ground.

2. Muting at a specific antenna input level

The DC voltage at terminal no.12 of PA3001 is set to read at least 1.3V when the antenna input is less than 14dB ($5\mu V$) with the MUTING switch in position 1, and less than 29dB ($28\mu V$) in position

two. The adjustments are made by the semi-variable resistors VR_4 and VR_5 respectively. The output of terminal no.12 of PA3001 is connected via S_{2-b} and S_3 to terminal no.8 of PA1002, so that when an output voltage in excess of 1.3V appears at terminal no.12 of PA3001, the switch circuit in PA1002 is activated, thus bringing the muting circuit into operation.

3. Muting when not tuned to any station

When the tuned frequencies separated by about $\pm 70kHz$ from the broadcasting frequency, a DC voltage appears at terminal no.12 of PA3001. This voltage activates the switch circuit incorporated inside PA1001, thus bring the muting circuit into operation.

4. Muting when the IF BAND switch is switched

The Q_{19} base voltage is designed to drop to 0V during the instant the IF BAND switch (S_4) is changed. (both contacts open during the switching action). Consequently, Q_{19} is turned ON, resulting in +B passing via Q_{19} to charge C_{75} , as well as passing via D_{12} to terminal no.8 of PA1002, whose switch circuit is then activated.

5. Muting when the FUNCTION switch is switched

The Q_{19} base voltage drops to 0V during the instant when the FUNCTION switch (S_1) is turned from AM to FM, resulting in the momentary opening of the +B switching section of the FUNCTION switch. This results in Q_{19} turning ON, with all consequent steps being the same as when the IF BAND switch was changed.

Furthermore, Q_2 has been added to the circuit in

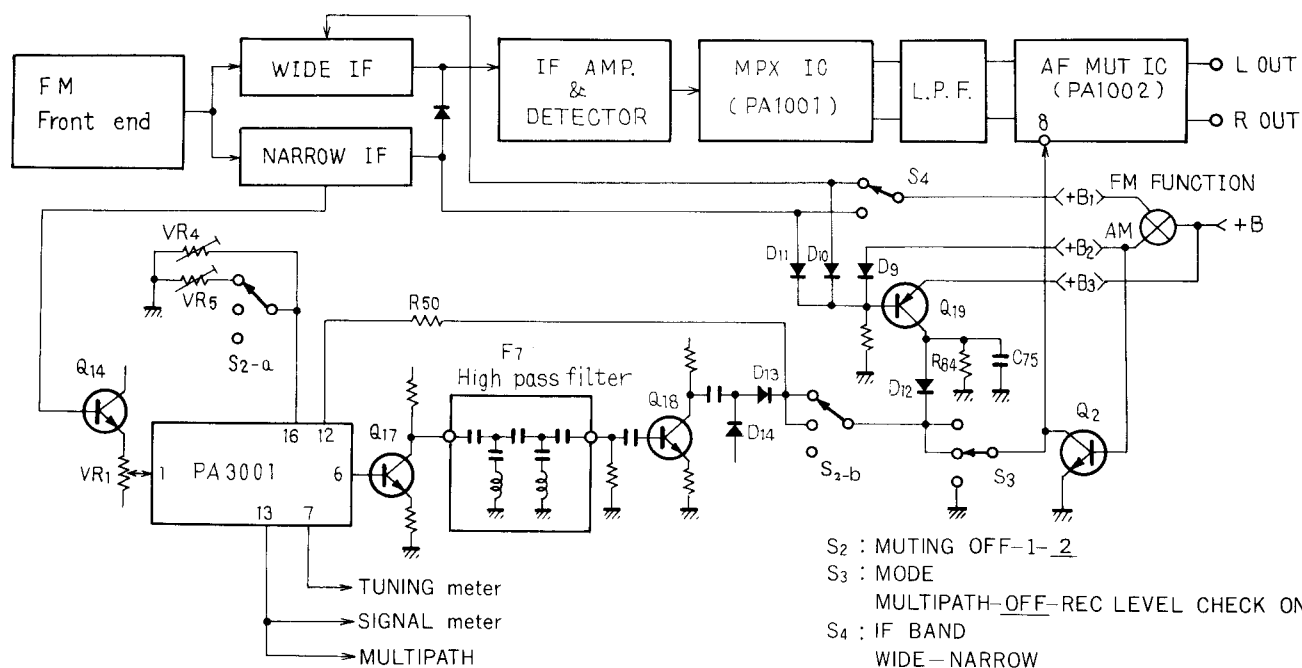

Fig. 7 FM control circuit

order to prevent muting when the FUNCTION switch is turned to the AM position. In this case +B₂ is applied to the bases of both Q₁₉ and Q₂, turning Q₁₉ OFF, and Q₂ ON. Therefore, terminal no.8 of PA1002 is connected to ground, thus preventing the muting circuit from operating.

The muting action is also inhibited when the MODE switch (S₃) is turned to the REC LEVEL CHECK position. In this case, the MODE switch shorts terminal no.8 directly to ground.

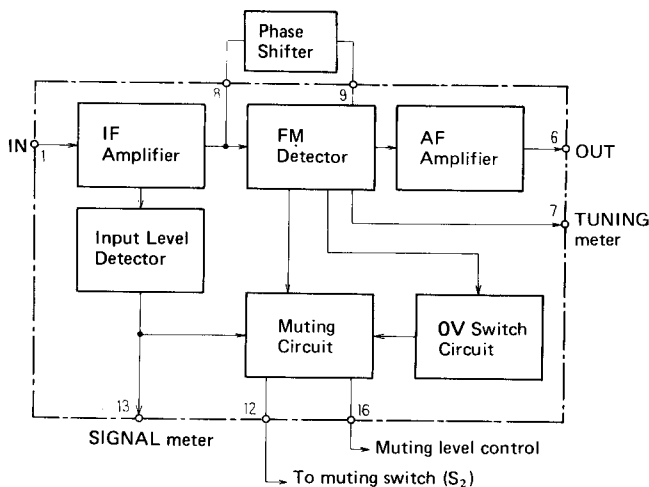

Fig. 8 Block diagram of PA3001

5.3 REC LEVEL CHECK SIGNAL GENERATOR CIRCUIT

This circuit, consisting of one transistor and an IC

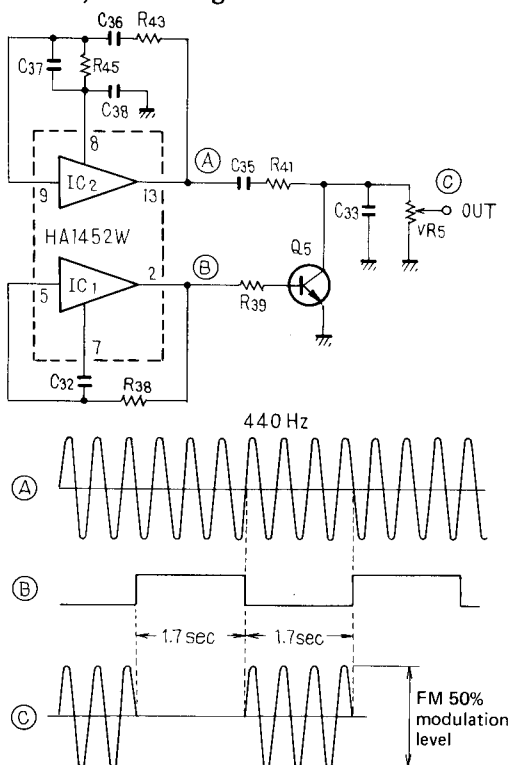

Fig. 9

(HA1452W), produces tone bursts every 3.4 sec. for 1.7 sec. intervals by means of a 440Hz signal. The output level corresponds to a value equivalent to an FM broadcast with 50% modulation. The circuit is outlined in Fig. 9.

The IC HA1452W incorporates two pairs of operational amplifiers, one being used as a 440Hz sine wave oscillator circuit, and the other as square wave oscillator, which cycles on and off every 3.4 sec. for 1.7 sec. The switching action of Q₅ converts this square wave into tone bursts. When the square wave is applied to the base of Q₅, Q₅ is turned ON and OFF, thus converting into a 440Hz tone bursts.

5.4 POWER SUPPLY CIRCUIT

This circuit, too, employs one of Pioneer's recently developed ICs (PA2002), resulting in better S/N ratio, stability, and a greater degree of reliability.

PA2002 is an IC used to provide constant voltages, and incorporates a protection circuit. A block diagram is outlined in Fig. 10.

The protection circuit is composed of control circuits activated by overcurrents, and control circuits activated by overvoltages. The protection circuit is activated when either a current in excess of 760mA (resulting from an overload) flows through the IC output (terminal no.10), or a voltage in excess of 27V is applied to the IC input (terminal no.1). Once this protection circuit is activated, no output voltage will appear at terminal no.10.

Fig. 11 is an outline of the power supply circuit used in TX-9500II. The Q₁ has been included in this circuit in order to take up any excess currents above the maximum current for the PA2002.

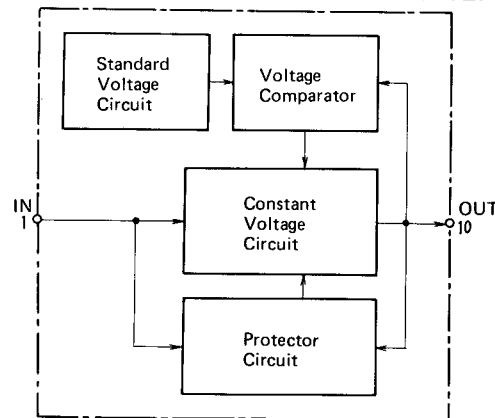

Fig. 10 Block diagram of PA2002

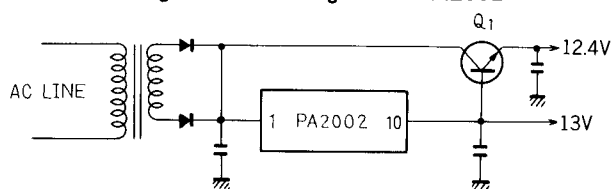

Fig. 11 Power supply circuit

6. DISASSEMBLY

1. Remove the 4 screws (A) securing both sides of the bonnet case.
2. Remove the 9 screws (B) securing the bottom plate.
3. Remove all the knobs from the front panel. In the case of the TUNING knob, a securing screw must first be loosened. Now remove the 3 nuts (C) and the 2 screws (D) securing the top of the front panel, which may now be taken off.

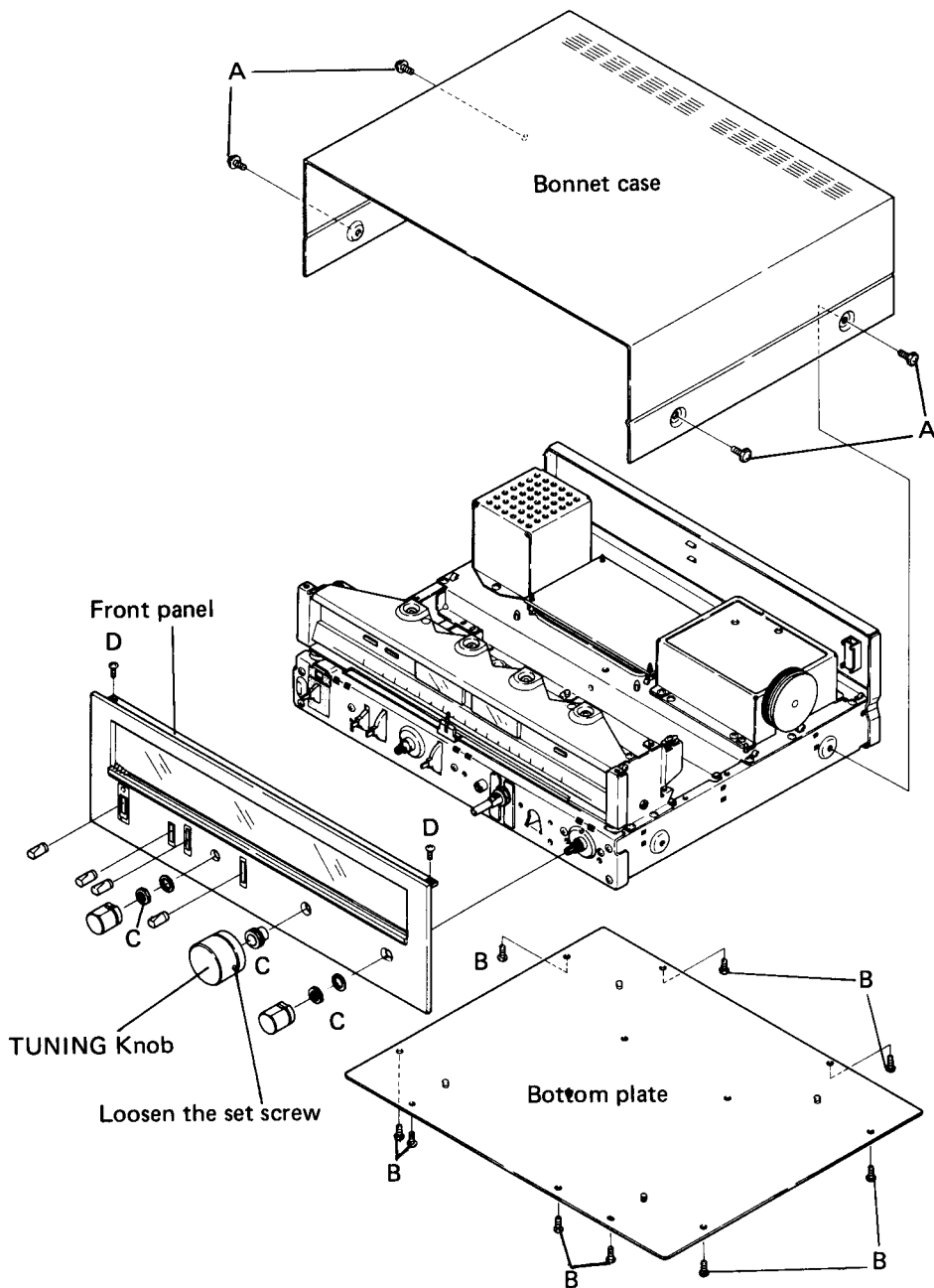
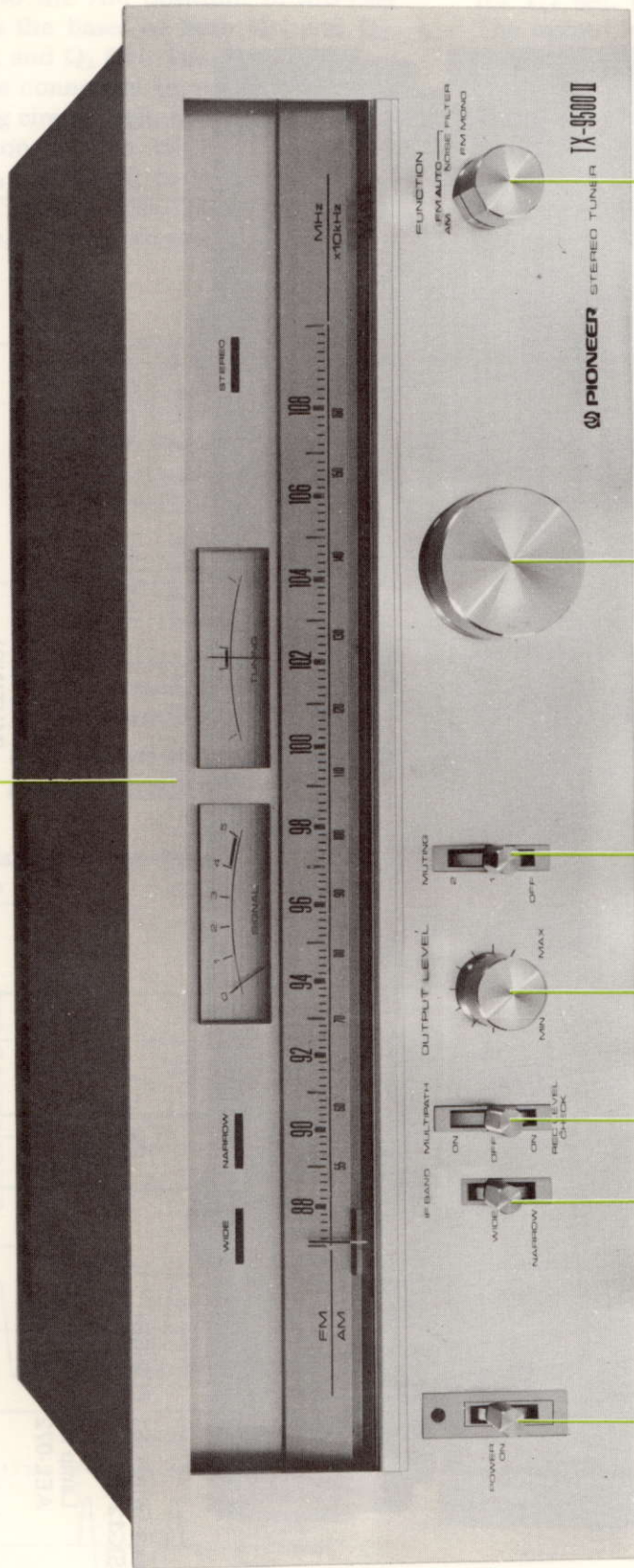

Fig. 12

7. PARTS LOCATION

7.1 FRONT PANEL VIEW

Front panel assembly
ANB-485



Knob (POWER)
AAD-117

Knob (IF BAND)
AAD-117

Knob (MODE)
AAD-117

Knob (OUTPUT LEVEL)
AAB-116

Knob (MUTING)
AAD-117

Knob (TUNING)
AAA-038

Knob (FUNCTION)
AAB-116

7.2 FRONT VIEW WITH PANEL REMOVED

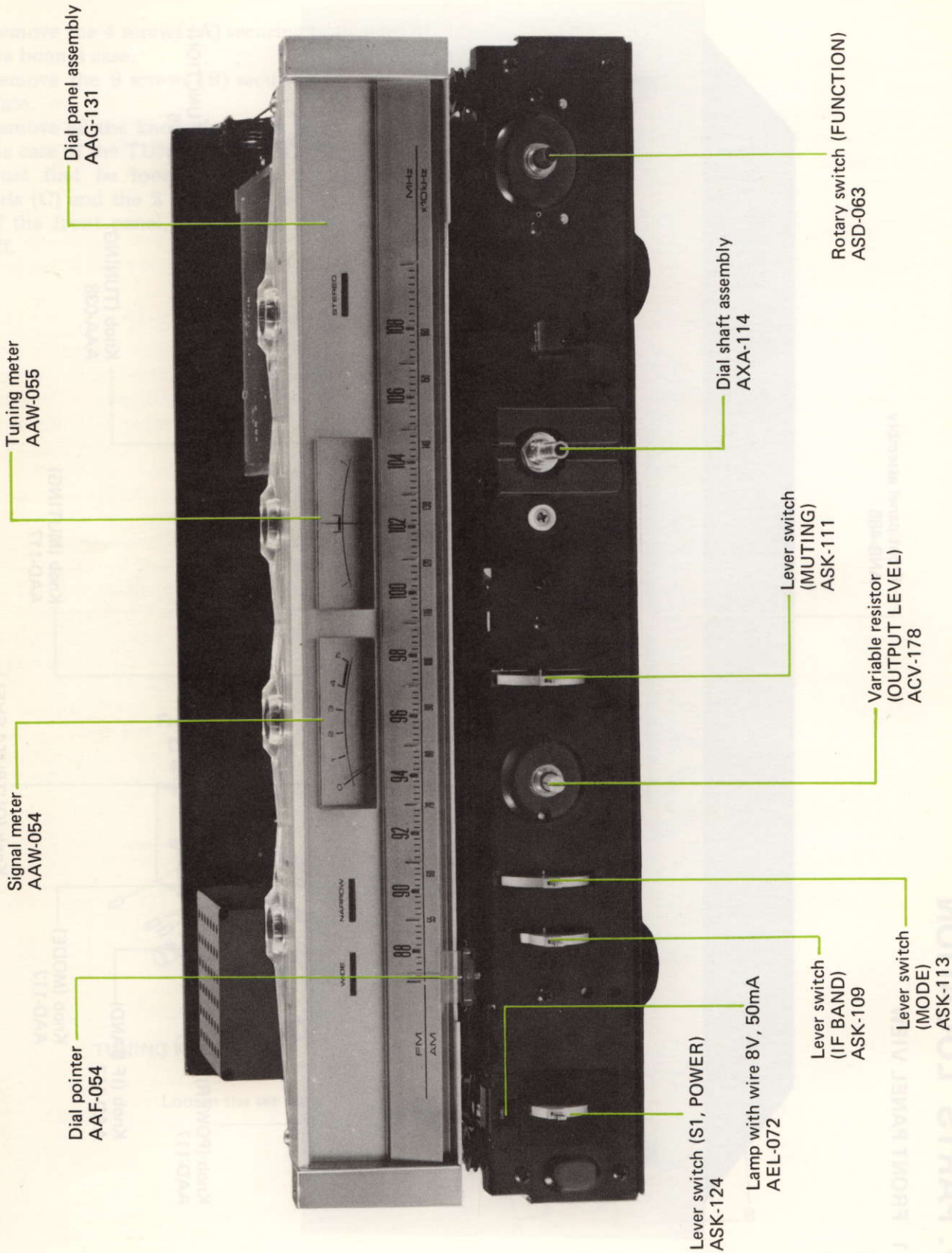

7.3 TOP VIEW

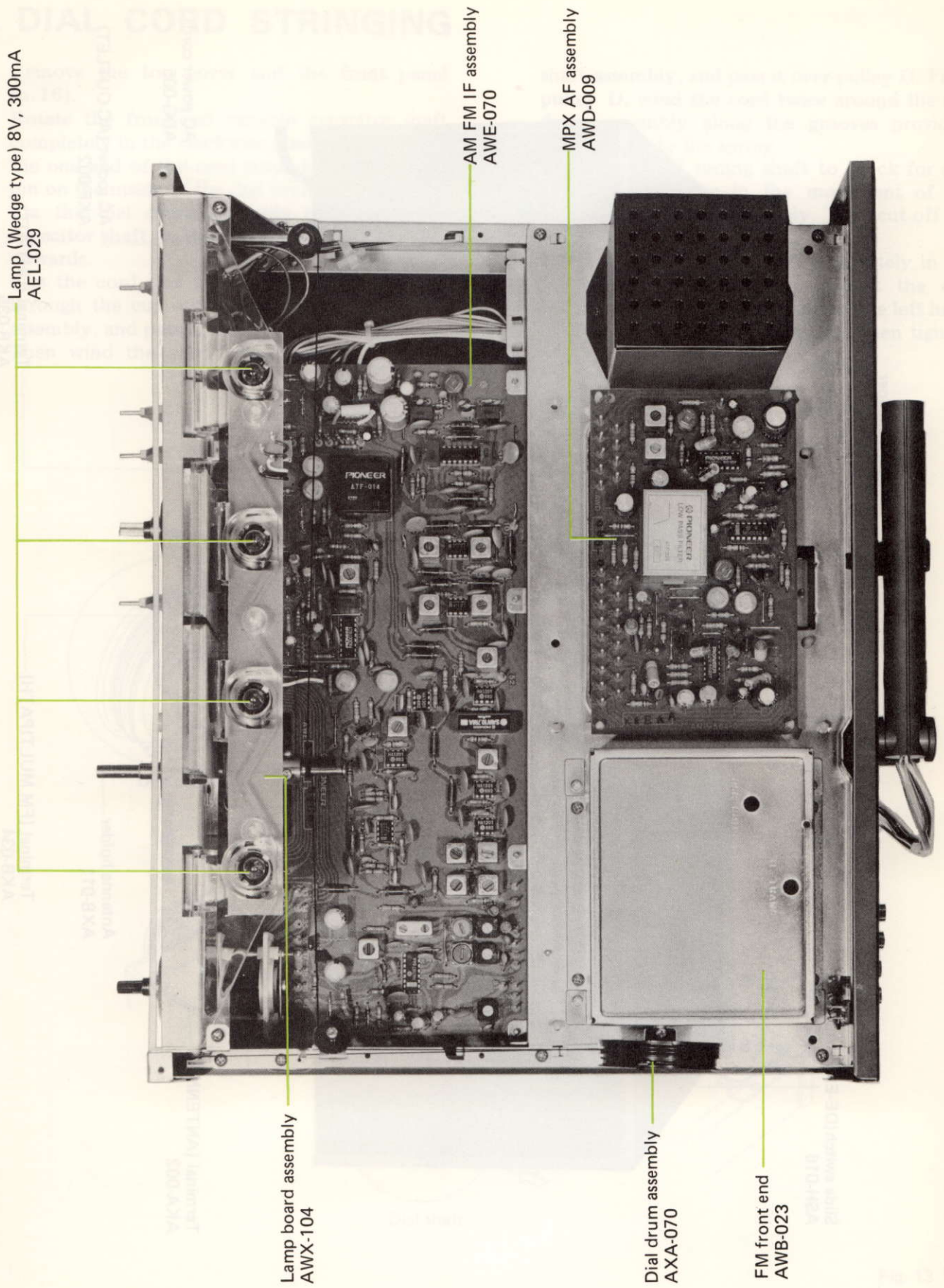

8. DIAL CORD STRINGING

1. Remove the top cover and the front panel (p. 16).
2. Rotate the front-end variable capacitor shaft completely in the clockwise direction.
3. Tie one end of the cord around the protruding pin on the inside of the dial drum assembly.
4. Fix the dial drum assembly to the variable capacitor shaft so that the set screw is pointing upwards.
5. Pass the cord tied to the dial drum assembly through the cut out section of the dial drum assembly, and pass it over pulley A, B and C.
6. Then wind the cord 3 times around the dial shaft assembly, and pass it over pulley D. From pulley D, wind the cord twice around the dial drum assembly along the grooves provided, and then tie to the spring.
7. Rotate the dial tuning shaft to check for any abnormal behavior in the movement of the cord and dial drum assembly. Then cut off the remaining cord.
8. Rotate the dial tuning shaft completely in the counterclockwise direction. Adjust the dial indicator to the starting point on the left hand side of the tuning dial scale, and then tighten the cord.

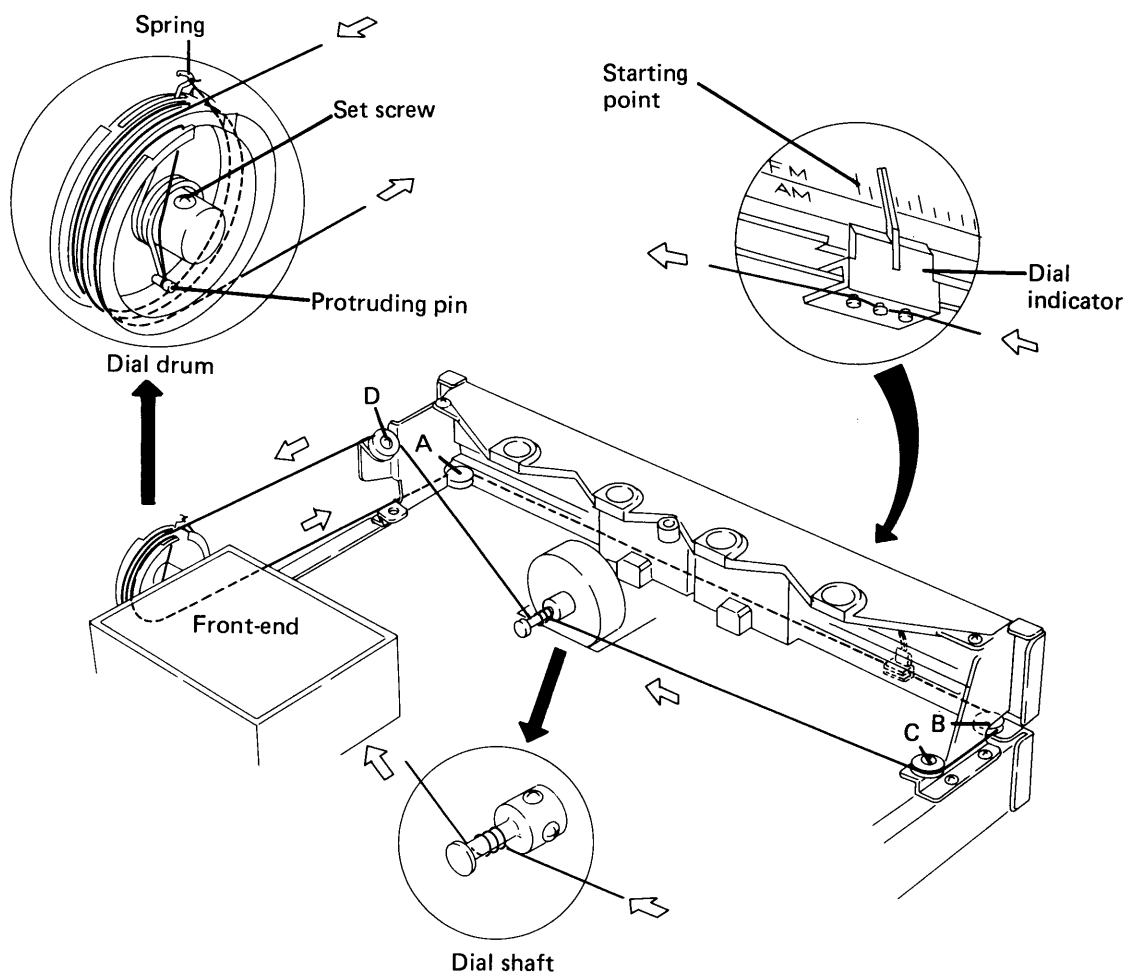

Fig. 13

9. ADJUSTMENTS

9.1 FM SECTION

FM Front-end

When the TUNING knob is turned completely in the counterclockwise direction, the dial indicator should be aligned with the starting point on the far left of the dial scale.

1. Turn the MUTING, MULTIPATH, and REC LEVEL CHECK switches on the front panel to the OFF positions. Turn the IF BAND switch to the NARROW position, and the FUNCTION switch to the FM MONO position.
2. Connect the test instruments as shown in Fig. 14, and adjust FM SG to 90MHz, modulation frequency to 400Hz, 100% modulation, and output of 10dB.
3. Set the dial indicator of the TX-9500II to 90MHz, and adjust each of the cores L_O , L_A , L_{R1} , L_{R2} , and L_{R3} in the front-end for maximum deflection on the AC voltmeter.
4. Now set the dial indicator of TX-9500II and FM SG to 106MHz, and adjust each of the trimmers TC_O , TC_A , TC_{R1} , TC_{R2} , and TC_{R3} in the FM front-end (Fig. 15) to give maximum deflection on the AC voltmeter.

5. Repeat steps 2 to 4 so that the AC voltmeter deflections are more or less the same at both 90MHz and 106MHz.
6. Once these adjustments have been completed, check that there are no oscillations etc.

FM Muting Circuit

1. Connect the test instruments as shown in Fig. 16.
2. Turn the MUTING, MULTIPATH, and REC LEVEL CHECK switches on the front panel to

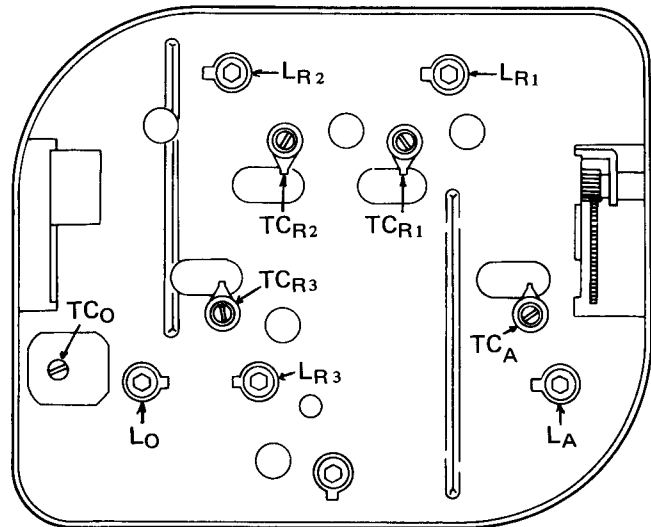

Fig. 15 Bottom view of FM front-end

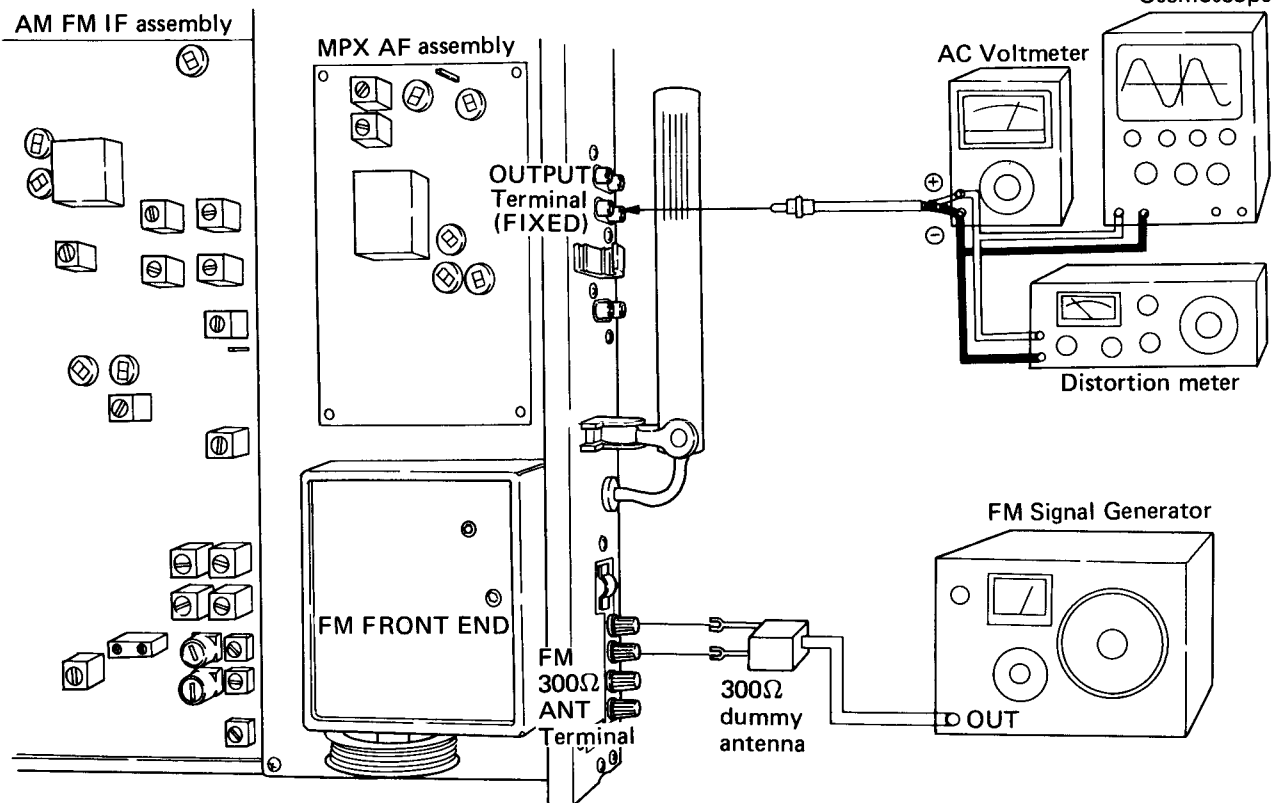

Fig. 14

- the OFF positions, turn the IF BAND switch to the NARROW position, and the FUNCTION switch to the FM AUTO position..
- Set the semi-variable resistors ($VR_2 - VR_5$) of the AM FM IF assembly to the mechanical center points, but turn VR_1 in the maximum clockwise direction.
 - Set FM SG to modulation frequency of 400Hz, 100% modulation, and output of 60dB.
 - Tune the dial indicator of TX-9500II and FM SG to 98MHz (maximum SIGNAL meter deflection).
 - Lower the output of the FM SG to a level (about 10dB) where the SIGNAL meter is no longer effected by the limiter.
 - Adjust the FM front-end IF TRANS to give maximum SIGNAL meter deflection.
 - Turn the FM SG output level down until only the noise level remains, and adjust the core of T_{12} to bring the TUNING meter needle to the center marker.
 - Set the IF BAND switch to the WIDE position, and the FM SG output level to 60dB.
 - Tune the TX-9500II to 98MHz with the TUNING meter needle at the center marker.
 - Reduce the FM SG output down to a level (about 20-30dB) where the DC voltmeter is no longer effected by the limiter (point just below where any increase in FM SG output stops producing a change in DC voltmeter reading.).
 - Adjust the cores of T_1 to T_5 until the DC voltmeter gives maximum reading.
 - Return the FM SG output level to 60dB, and adjust the cores of T_{11} , T_{10} , T_8 , T_9 , and T_7 consecutively in this order to reduce distortion to a minimum use a distortion meter for this measurement. Repeat the process until the minimum is reached. Then adjust further with VR_2 .
 - Set the FM SG output to 80dB, and then adjust VR_3 so that the SIGNAL meter reads 4.8 on the scale.
 - Reset the FM SG output to 50dB, and adjust (by VR_1) the SIGNAL meter to read 4.
 - Repeat steps 14 and 15 until the required SIGNAL meter readings are attained.
 - Set the FM SG output to 14dB, and turn the MUTING switch to position 1.
 - Adjust VR_4 to the point where the muting circuit is activated.
 - Reset the FM SG output to 29dB, and turn the MUTING switch to position 2.
 - Adjust VR_5 to the point where the muting cir-

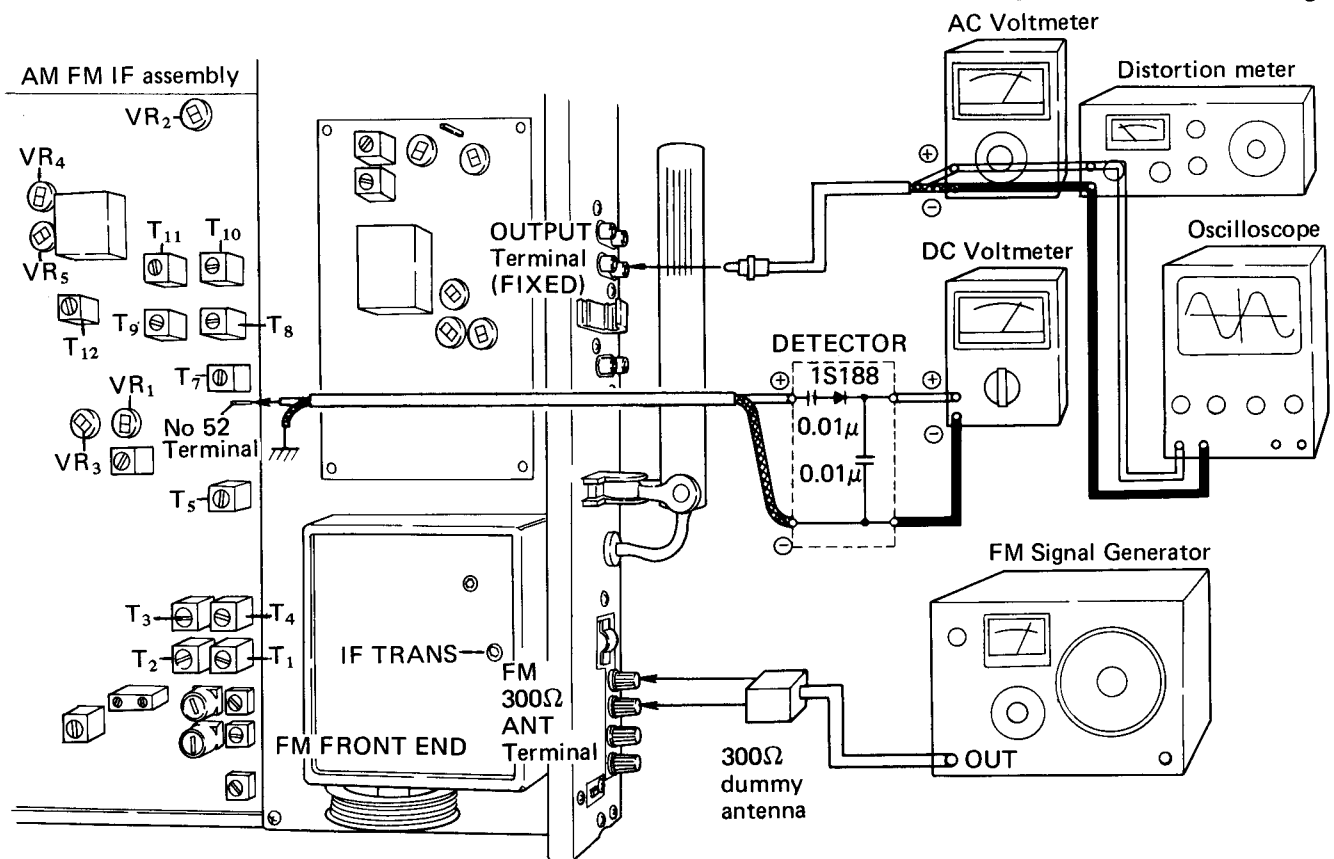

Fig. 16

cuit is activated.

- Turn the FM SG output level down until there is only noise, and check that the TUNING meter is still at the center marker. If it is not aligned correctly, repeat the above procedure starting from step 8.

FM MPX Circuit

- Connect the test instruments as shown in Fig. 17.
- Turn the MUTING, MULTIPATH, and REC LEVEL CHECK switches on the front panel to the OFF positions, turn the IF BAND switch to the WIDE position, and the FUNCTION switch to FM AUTO.
- Set FM SG to zero modulation, and 60dB, at 98MHz.
- Tune the dial indicator of TX-9500II to 98MHz.
- Connect the PILOT OUT terminal of MPX SG to the HORIZONTAL input terminal of an oscilloscope, and terminal no.27 of the MPX AF assembly (via a 10:1 probe) to the VERTICAL input terminal.
- Adjust VR₁ of the MPX AF assembly to stop the Lissajous waveform in the oscilloscope (see Fig. 18).

- With the FM SG as external modulation, and the MPX SG output as the pilot signal (19kHz) only, this signal is applied with 7.5kHz deviation (10%) to the external modulation input terminal of the FM SG.
- Adjust VR₂ of the MPX AF assembly to reduce the pilot signal leakage appearing at the output terminal of TX-9500II to a minimum.
- The 67.5kHz deviation L + R (1kHz) and the 7.5kHz deviation pilot signal (19kHz) are taken as the MPX SG output signal.

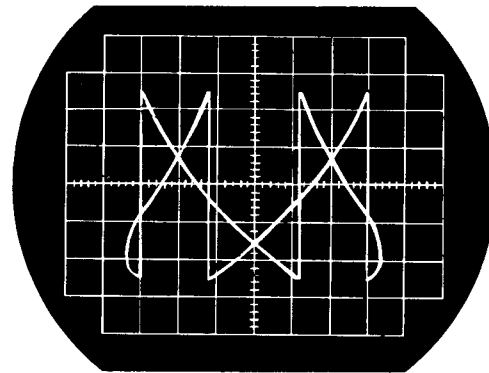

Fig. 18 Lissajous waveform

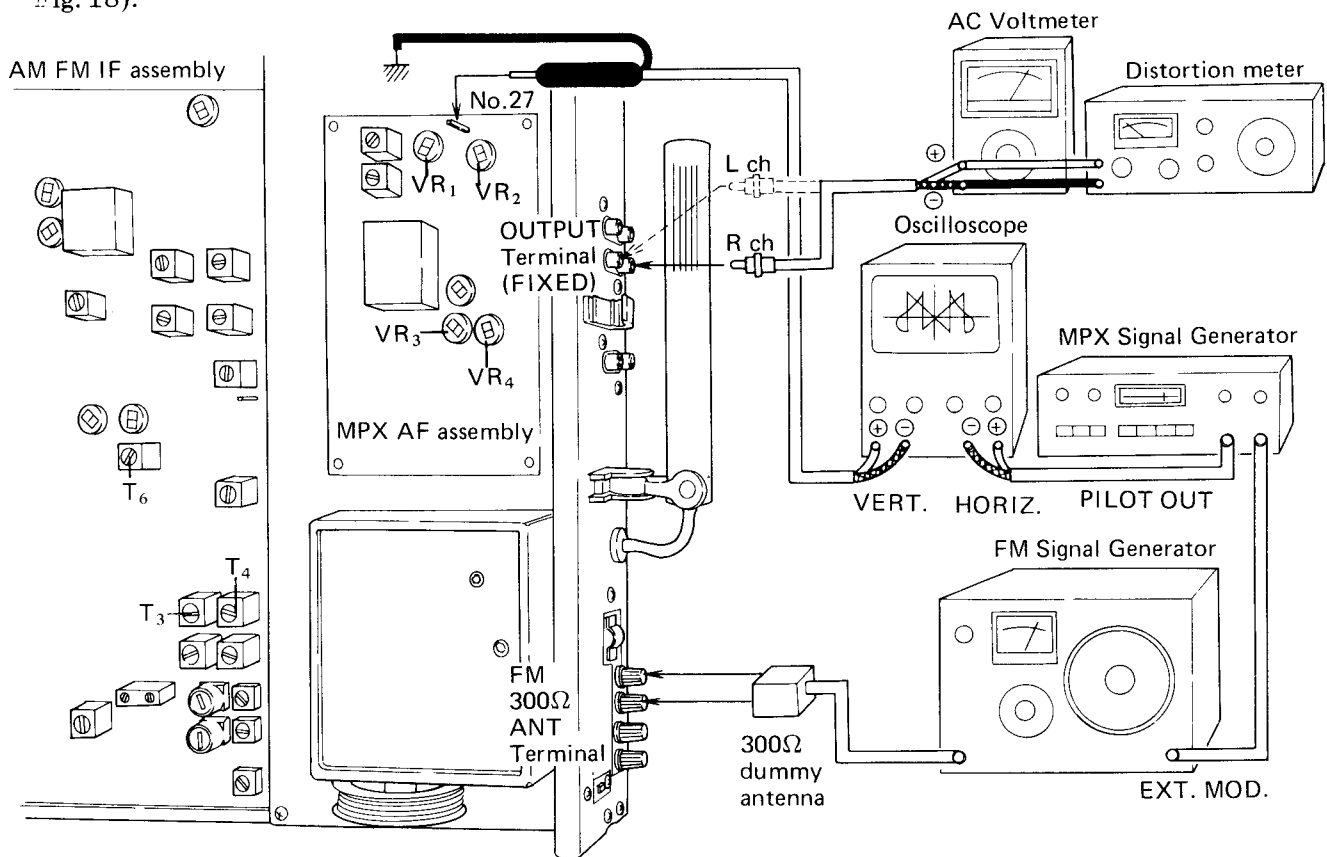

Fig. 17

10. Set the FM SG output level to 80dB, and reduce the distortion to a minimum by adjusting T_3 and T_4 of the AM FM IF assembly repeatedly.
11. Set the IF BAND switch to the NARROW position, and again reduce the distortion to a minimum by adjusting T_6 of the AM FM IF assembly.
12. Return the IF BAND switch back to the WIDE position, and pass the MPX SG main signal through either L or R.
13. Adjust VR_3 of the MPX AF assembly to get optimum channel separation.
14. Again set the IF BAND switch to the NARROW position, and adjust VR_4 of the MPX AF assembly to get optimum channel separation a second time.
15. Turn the FUNCTION switch to NOISE FILTER position, and check that a channel separation of $18\text{dB} \pm 3\text{dB}$ is obtained. When turned to the FM MONO position, the STEREO indicator lamp should go out, and a monaural signal be received.

Adjustment of the REC LEVEL CHECK Oscillation Level

1. Connect up the test instruments as shown in Fig. 19.
2. Turn the FUNCTION switch to FM AUTO.
3. With the FM SG at modulation frequency of 400Hz, 100% modulation, and an output of 60dB, check the output level of TX-9500II.
4. Turn the REC LEVEL CHECK to the ON position, and adjust VR_5 of the MPX AF assembly so that the output level is -6dB below the level found in step 3 above.

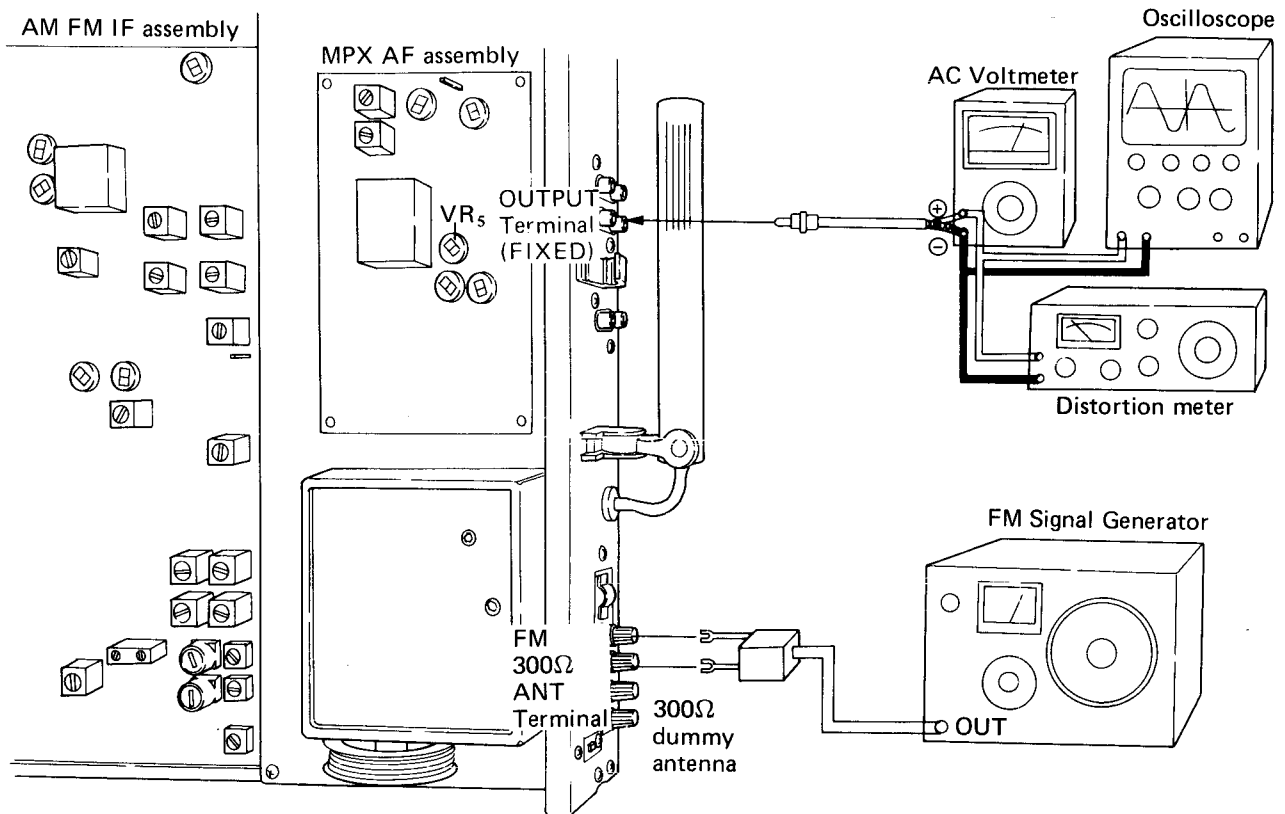

Fig. 19

9.2 AM SECTION

AM Tracking

Check that the dial indicator has been adjusted correctly to the starting point.

1. Turn the FUNCTION switch to the AM position.
2. Connect the test instruments as shown in Fig. 20, and adjust the AM Signal Generator (AM SG) to 400Hz modulation frequency, 30% modulation, and 30dB output.
3. Set the dial indicator of TX-9500II and AM SG to 600kHz, and adjust cores of T_{14} and T_{13} on the AM FM IF assembly then the core of the bar antenna to produce the maximum output from TX-9500II.
4. Now set the dial indicator and AM SG to 1400kHz, and again adjust for maximum output, but by means of the TC_3 , TC_2 , and TC_1 trimmers.
5. With complete reception of the 600kHz and 1400kHz signals, repeat steps 3 and 4 to (minimize the amount of deviation between the two outputs.
6. Reset the dial indicator of TX-9500II and AM SG to 600kHz, and adjust to maximum output level by means of the T_{15} core.

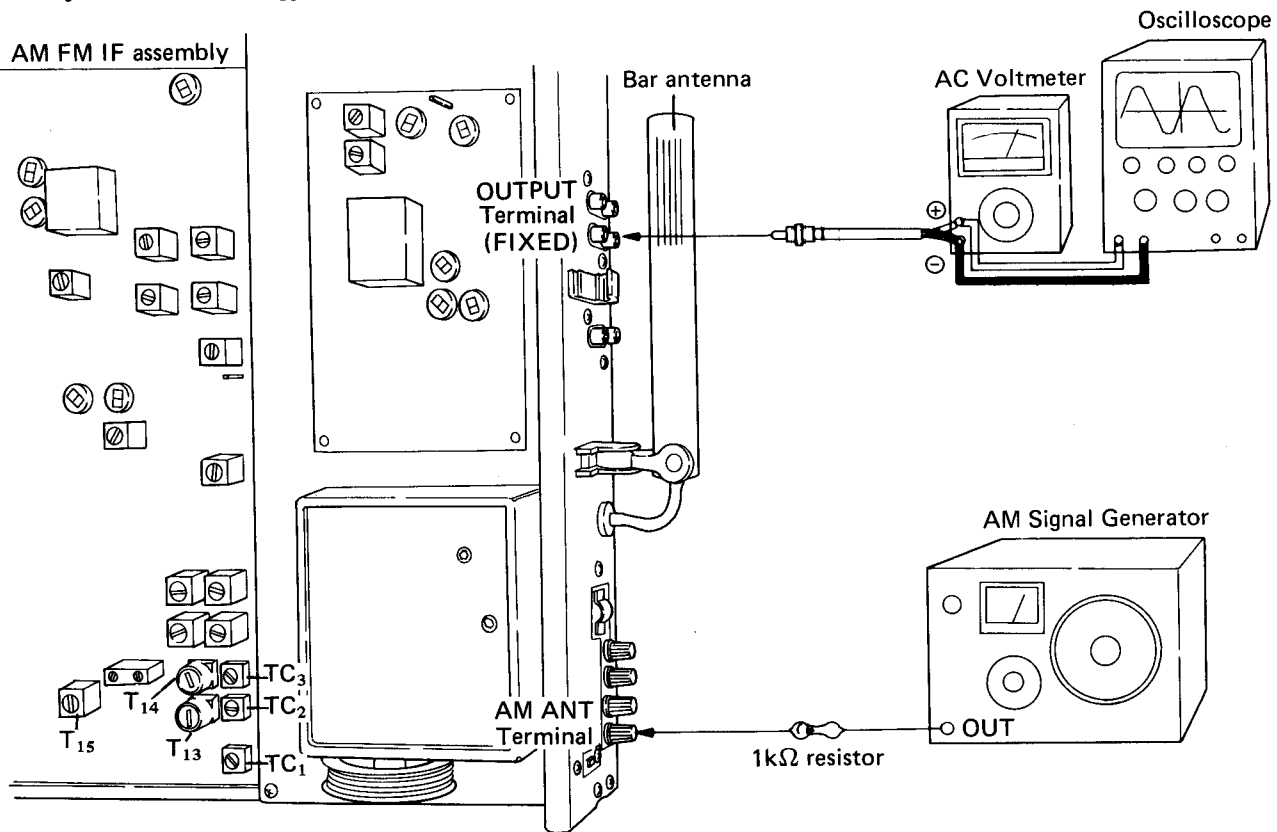
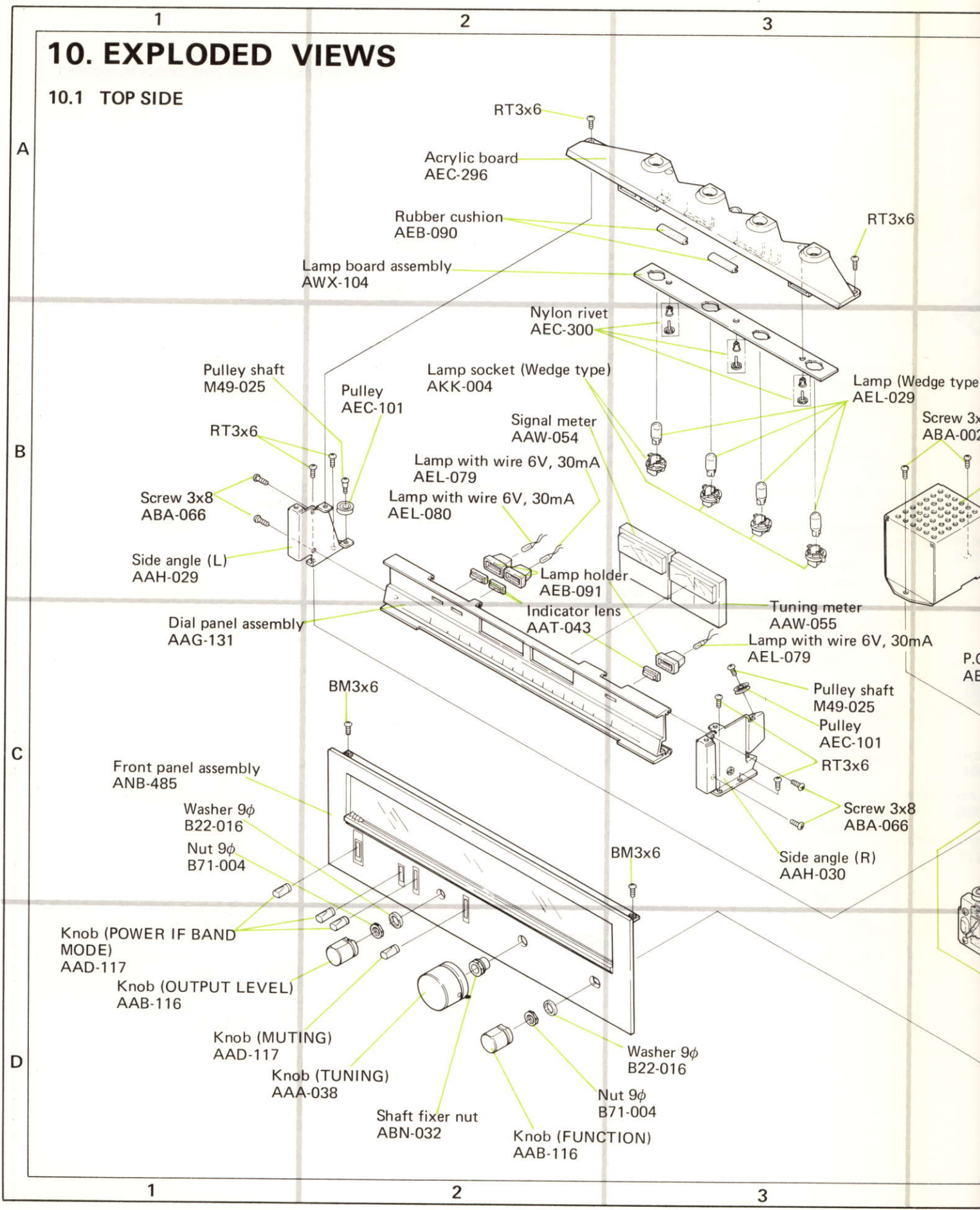

Fig. 20

10. EXPLODED VIEWS

10.1 TOP SIDE



4

5

6

NOTE:
Parts indicated in green type cannot be supplied.

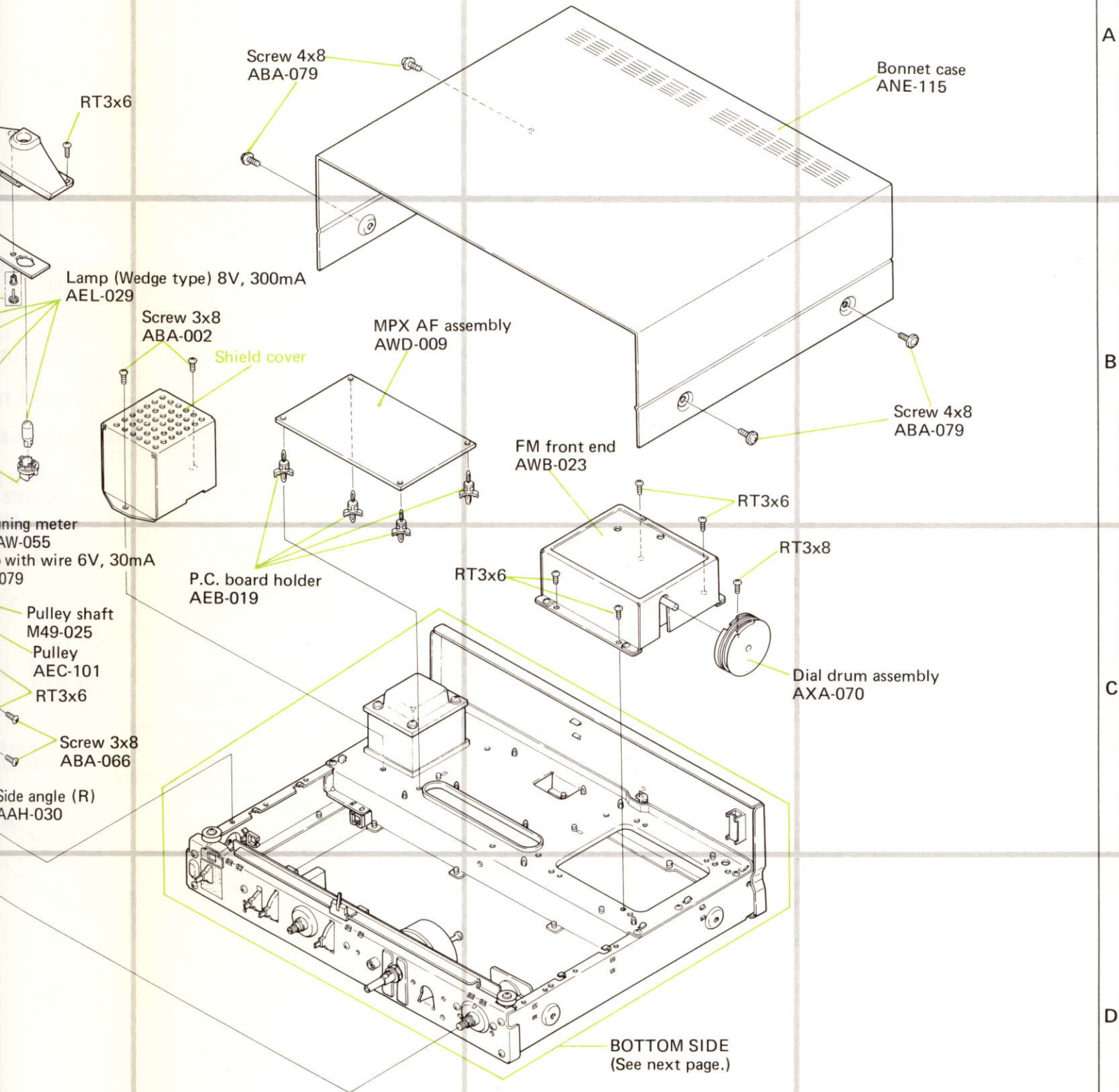

A

B

C

D

4

5

6

4

5

6

NOTE:
Parts indicated in green type cannot be supplied.

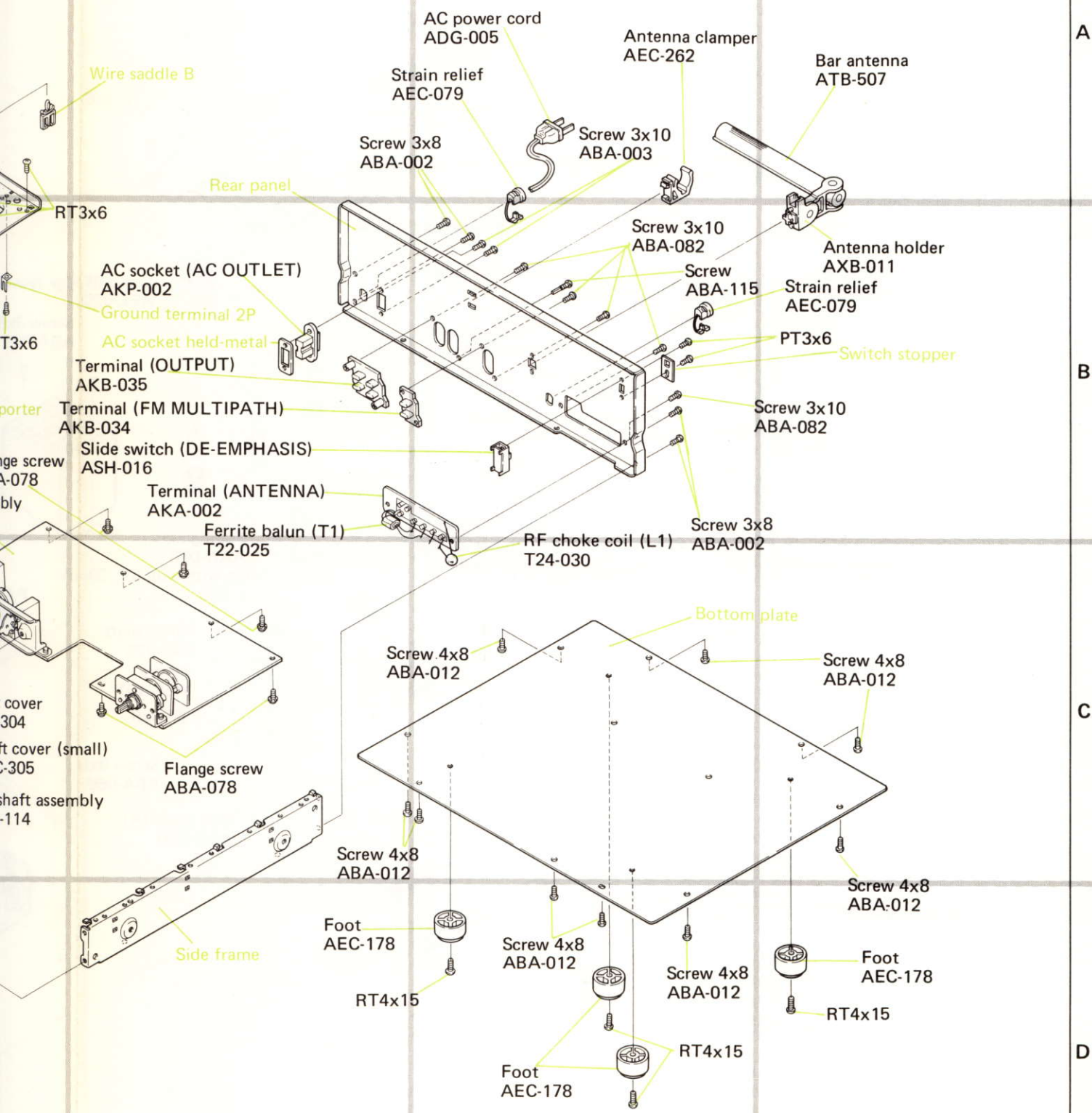

A

B

C

D















4









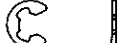

5

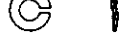
6

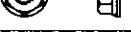
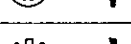
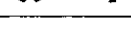
10.3 NOMENCLATURE OF SCREWS, WASHERS AND NUTS

The following symbols stand for screws, washers and nuts as shown in exploded view.

Symbol	Description	Shape
RT	Brazier head tapping screw	
PT	Pan head tapping screw	
BT	Binding head tapping screw	
CT	Countersunk head tapping screw	
TT	Truss head tapping screw	
OCT	Oval countersunk head tapping screw	
PM	Pan head machine screw	
CM	Countersunk head machine screw	
OCM	Oval countersunk head machine screw	
TM	Truss head machine screw	
BM	Binding head machine screw	
PSA	Pan head screw with spring lock washer	
PSB	Pan head screw with spring lock washer and flat washer	
PSF	Pan head screw with flat washer	

Symbol	Description	Shape
EW	E type washer	
FW	Flat washer	
SW	Spring lock washer	
N	Nut	
WN	Washer faced nut	
ITW	Internal toothed lock washer	
OTW	Outernal toothed lock washer	
SC	Slotted set screw (Cone point)	
SF	Slotted set screw (Flat point)	
HS	Hexagon socket headless set screw	
OCW	Oval countersunk head wood screw	
CW	Countersunk head wood screw	
RW	Round head wood screw	

EXAMPLE

PM · 3x8
 length in mm (l)
 diameter in mm (d)
 Symbol

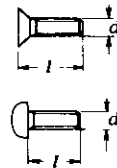

FW · 9φ x 1^t
 thickness in mm (t)
 diameter in mm (d)
 Symbol

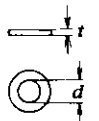

11. PACKING

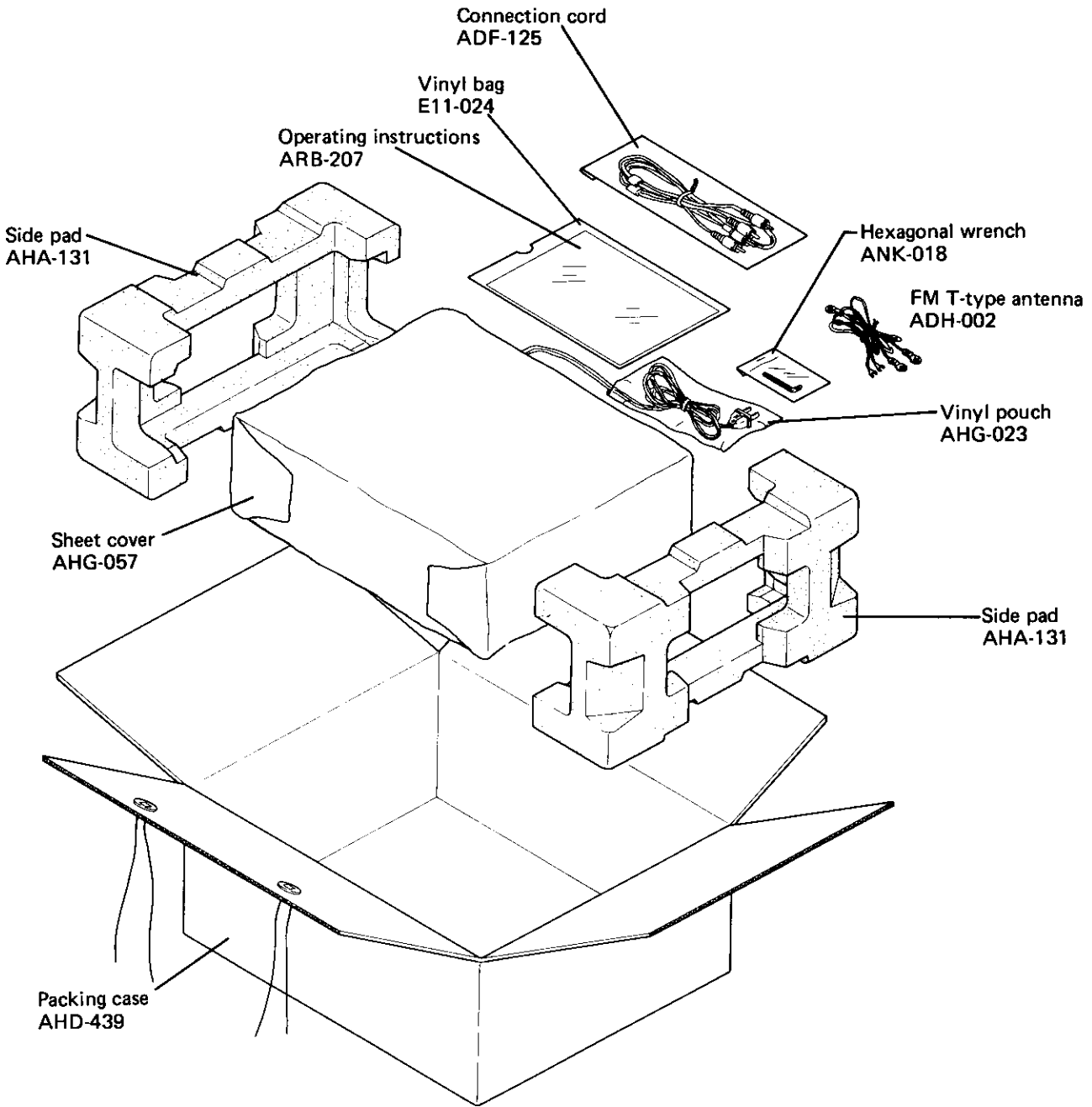

12. SCHEMATIC DIAGRAMS, P.C. BOARD PATTERNS AND PARTS LIST

12.1 SCHEMATIC DIAGRAM AND MISCELLANEOUS PARTS LIST

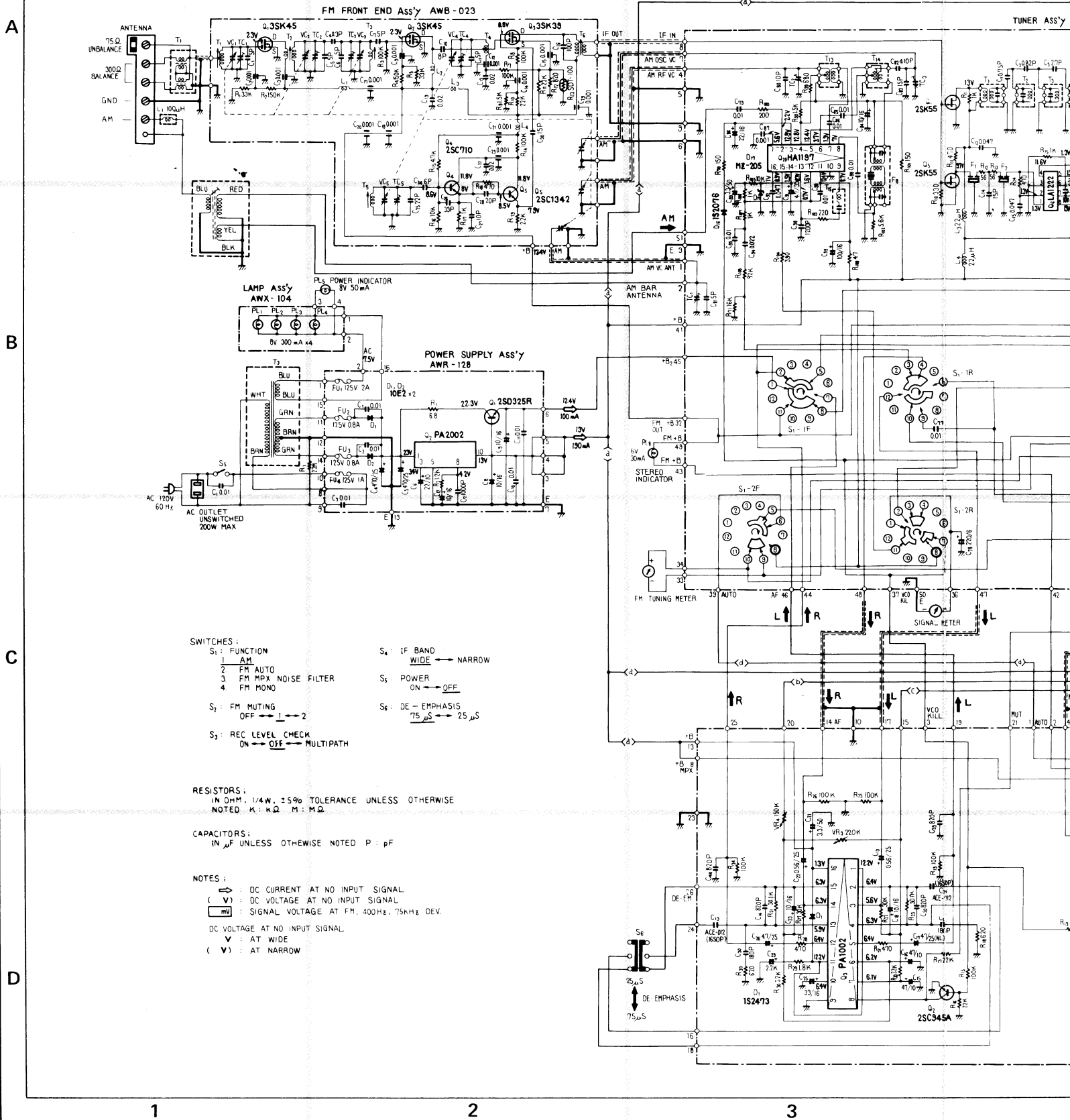

Miscellaneous Parts List

NOTE:

- Capacitors: in μF unless otherwise noted p:pF
- Resistors: in Ω , $\frac{1}{4}W$ unless otherwise noted k:k Ω , M:M Ω

SWITCHES

Symbol	Description	Part No.
S5	Lever switch (POWER)	ASK-124
S6	Slide switch (DE-EMPHASIS)	ASH-016

TRANSFORMERS AND COIL

Symbol	Description	Part No.
T1	Ferrite balun	T22-025
T2	Bar antenna	ATB-507
T3	Power transformer	ATT-347
L1	RF choke coil	T24-030

LAMPS

Symbol	Description	Part No.
PL1	Lamp (Wedge type) 8V, 300mA	AEL-029
PL2	Lamp (Wedge type) 8V, 300mA	AEL-029
PL3	Lamp (Wedge type) 8V, 300mA	AEL-029
PL4	Lamp (Wedge type) 8V, 300mA	AEL-029
PL5	Lamp with wire 8V, 50mA	AEL-072
PL6	Lamp with wire 6V, 30mA	AEL-080
PL7	Lamp with wire 6V, 30mA	AEL-079
PL8	Lamp with wire 6V, 30mA	AEL-079

FUSES

Symbol	Description	Part No.
FU1	Fuse 2A (Secondary)	AEK-103
FU2	Fuse 800mA (Secondary)	AEL-111
FU3	Fuse 800mA (Secondary)	AEK-111
FU4	Fuse 1A (Primary)	AEK-106

RESISTOR

Symbol	Description	Part No.
R1	Carbon film 2.2M $\frac{1}{4}W$	RD $\frac{1}{2}$ PS 225J

CAPACITORS

Symbol	Description	Part No.
C1	Ceramic 0.01 250V	ACG-001
C2	Ceramic 0.04 50V	CKDYF 403Z 50

External Appearances of Transistors

2SD325R
2SD325R

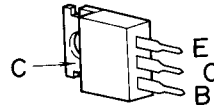

PA2002

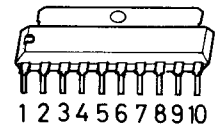

PA1001
PA1002
PA3001
HA1197

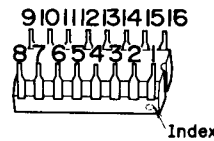

2SC945
2SA733

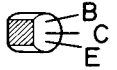

2SK55

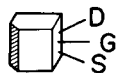

HA1452W
M5109PR

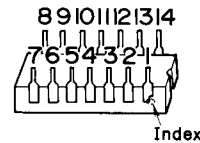

HA1201

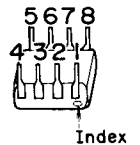

2SC461

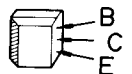

2SA725

2SC1312

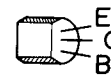

LA1222

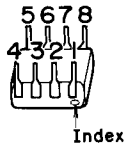

Circuit Diagrams of ICs

LA1222

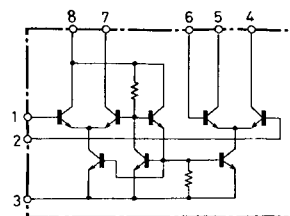

M5109PR

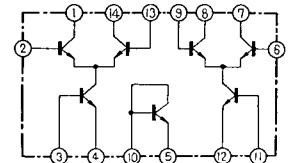

HA1452W

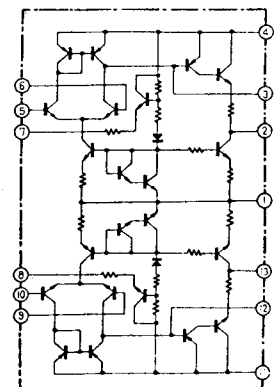

HA1201

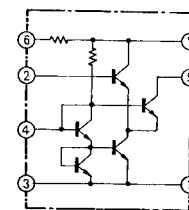

HA1197 (AM IC)

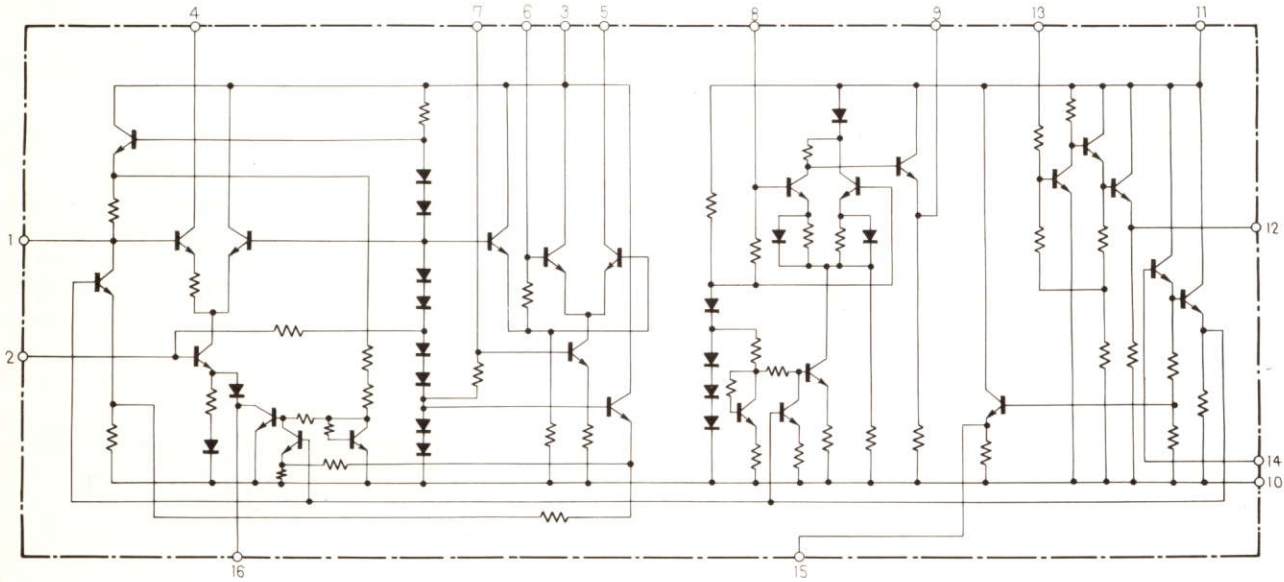

12.2 FM FRONT END (AWB-023)

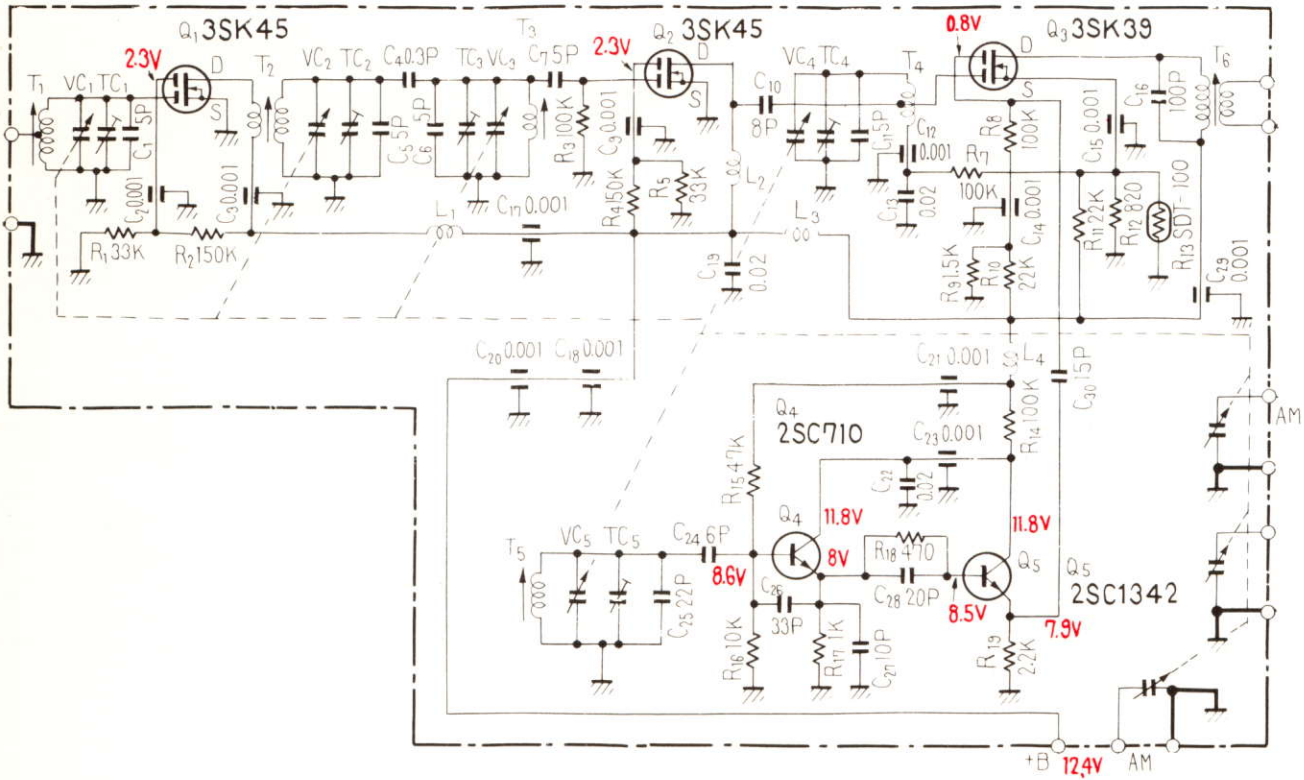

12.3 AM FM IF ASSEMBLY (AWE-070)

A
B
C
D

1 2 3

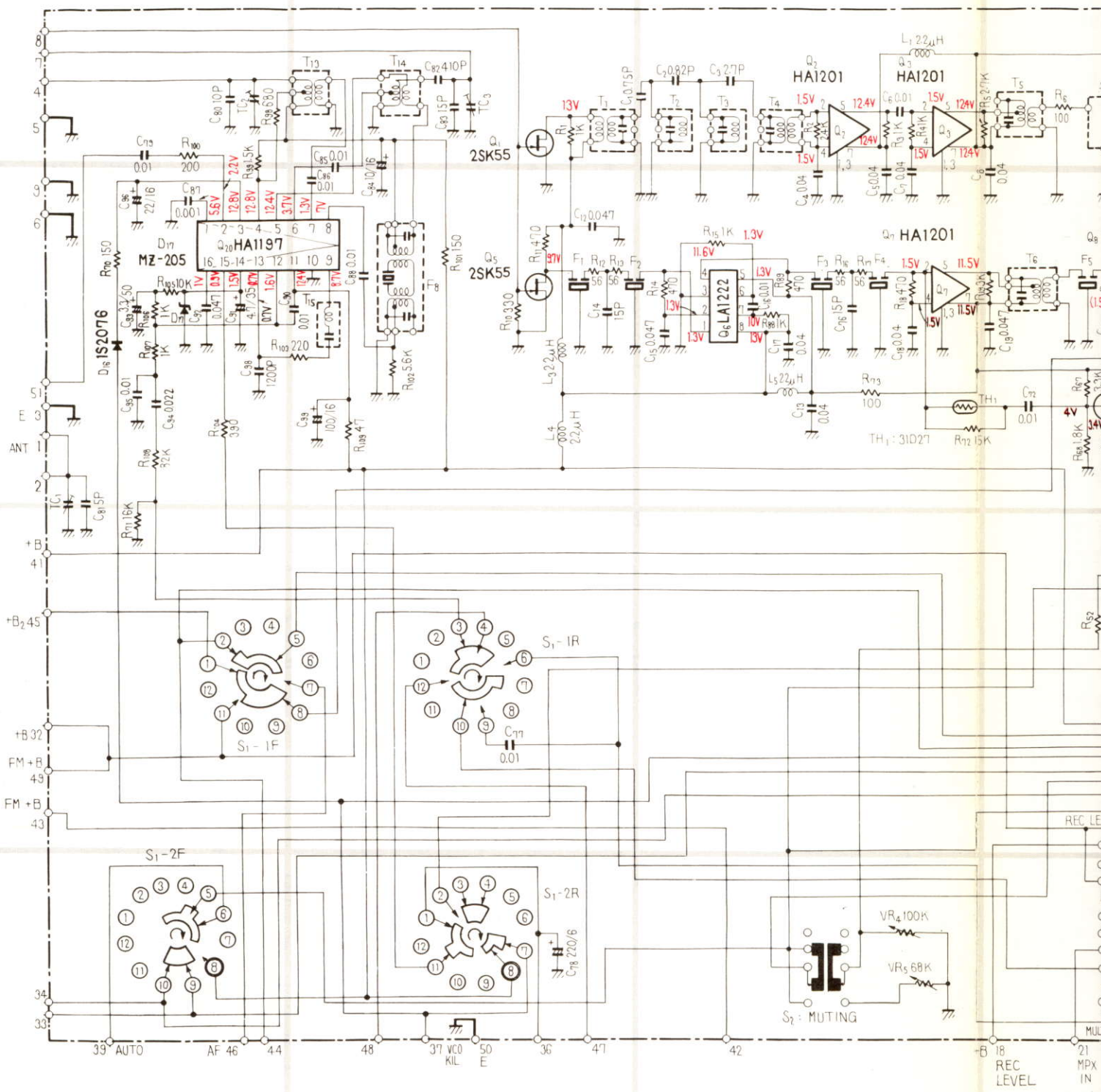

1 2 3

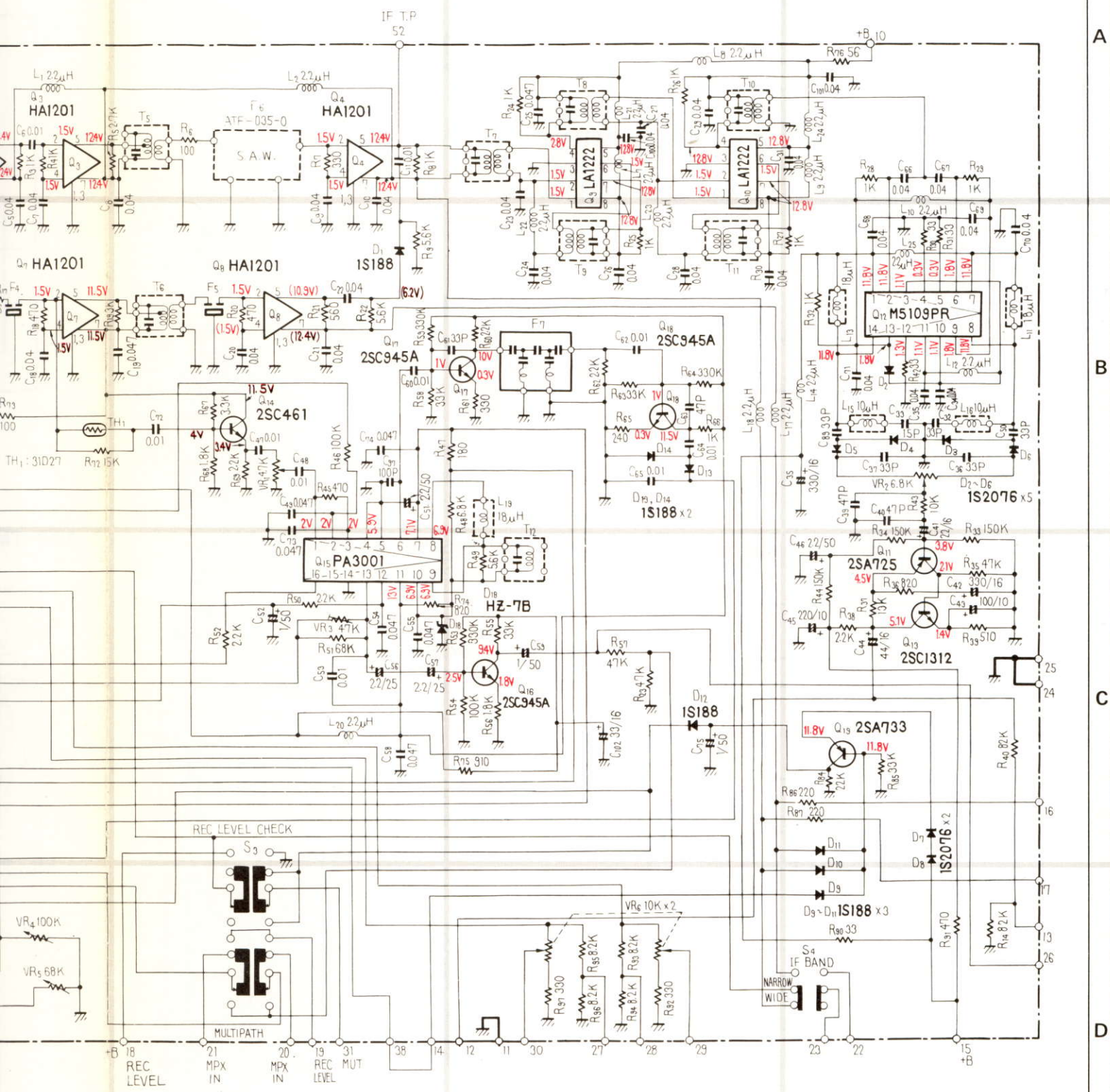

A

B

C

D

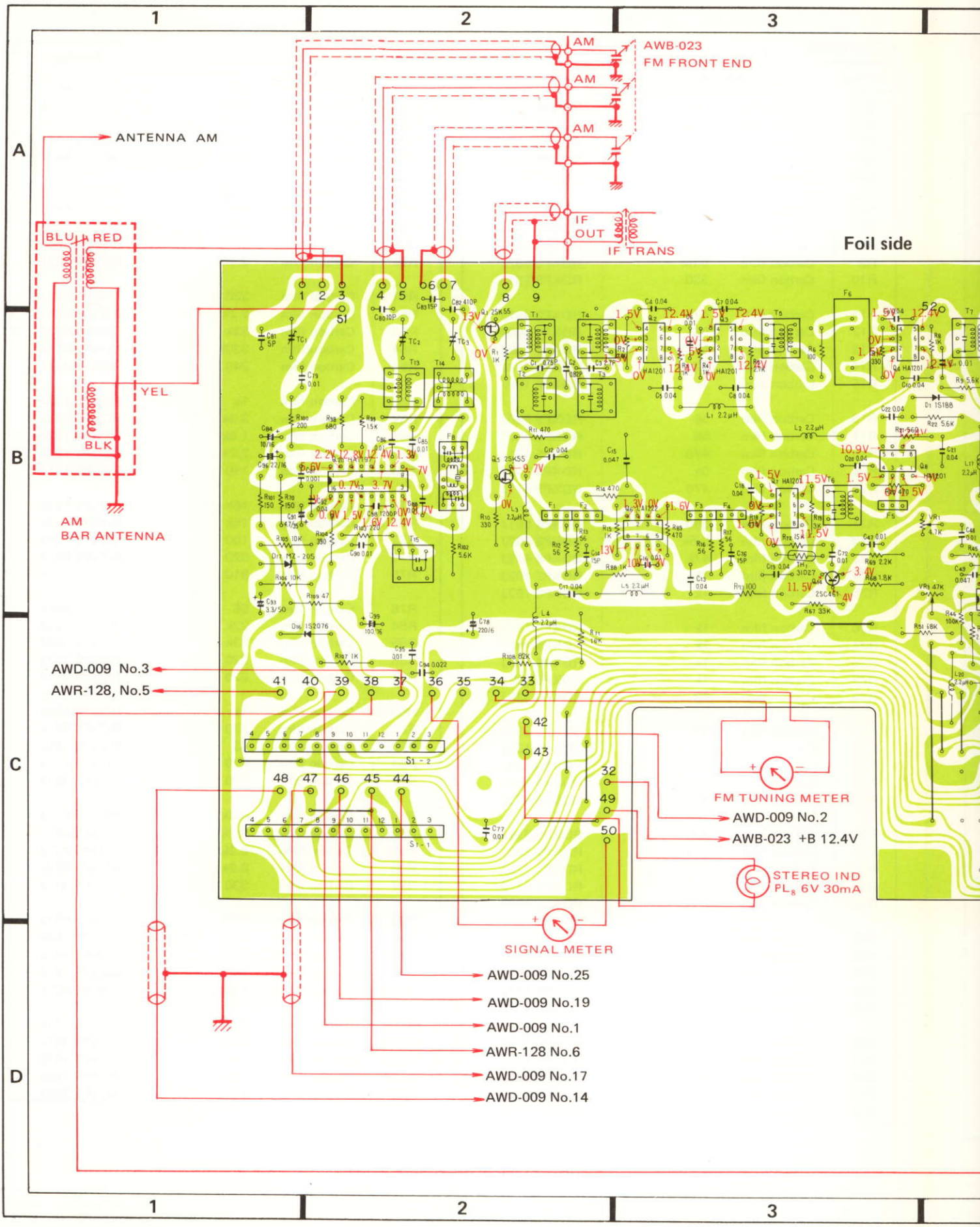

1

2

3

A

ANTENNA AM

BLU RED

YEL

BLK

AM BAR ANTENNA

AWB-023
FM FRONT END

IF OUT
IF TRANS

Foil side

AWD-009 No.3
AWR-128, No.5

FM TUNING METER

AWD-009 No.2
AWB-023 +B 12.4V

STEREO IND
PL₈ 6V 30mA

SIGNAL METER

AWD-009 No.25
AWD-009 No.19
AWD-009 No.1
AWR-128 No.6
AWD-009 No.17
AWD-009 No.14

1

2

3

D

Parts List of AM FM IF Assembly (AWE-070)

SEMICONDUCTORS

Symbol	Description	Part No.
Q1	FET	2SK55-D (2SK19-W or GR)
Q2	IC	HA1201
Q3	IC	HA1201
Q4	IC	HA1201
Q5	FET	2SK55-D (2SK19-W or GR)
Q6	IC	LA1222
Q7	IC	HA1201
Q8	IC	HA1201
Q9	IC	LA1222
Q10	IC	LA1222
Q11	Transistor	2SA725-G or H
Q12	IC	M5109PR
Q13	Transistor	2SC1312-G or H
Q14	Transistor	2SC461-B, A or C
Q15	IC	PA3001
Q16	Transistor	2SC945A-Q or R
Q17	Transistor	2SC945A-Q or R
Q18	Transistor	2SC945A-Q or R
Q19	Transistor	2SA733-Q or R
Q20	IC	HA1197
D1	Diode	1S188FM-1
D2	Diode	1S2076 (1S2473)
D3	Diode	1S2076 (1S2473)
D4	Diode	1S2076 (1S2473)
D5	Diode	1S2076 (1S2473)
D6	Diode	1S2076 (1S2473)
D7	Diode	1S2076 (1S2473)
D8	Diode	1S2076 (1S2473)
D9	Diode	1S188FM-1
D10	Diode	1S188FM-1
D11	Diode	1S188FM-1
D12	Diode	1S188FM-1
D13	Diode	1S188FM-1
D14	Diode	1S188FM-1
D16	Diode	1S2076 (1S2473)
D17	Zener diode	MZ 205-26A
D18	Zener diode	HZ7-B
TH1	Thermistor	31D27

TRANSFORMERS, COILS AND FILTERS

Symbol	Description	Part No.
T1	FM filter coil	ATE-031
T2	FM filter coil	ATE-032
T3	FM filter coil	ATE-032
T4	FM filter coil	ATE-033
T5	FM IF transformer	ATE-034
T6	FM IF transformer	ATE-035
T7	FM IF transformer	ATE-023
T8	FM IF transformer	ATE-023
T9	FM IF transformer	ATE-023
T10	FM IF transformer	ATE-023
T11	FM IF transformer	ATE-023
T12	FM detector transformer	ATE-027
T13	AM RF coil	ATB-052
T14	AM OSC coil	ATB-019
T15	455kHz filter	ATF-039
*F1~F6	FM combination filter	ATF-041
*F1	FM ceramic filter	ATF-040
*F2	FM ceramic filter	ATF-040
*F3	FM ceramic filter	ATF-040
*F4	FM ceramic filter	ATF-040
*F5	FM ceramic filter	ATF-040
*F6	FM SAW filter	ATF-035
F7	High pass filter	ATF-014
F8	AM ceramic filter	ATF-034
L1	RF choke coil 2.2 μ H	T24-028
L2	RF choke coil 2.2 μ H	T24-028
L3	RF choke coil 2.2 μ H	T24-028
L4	RF choke coil 2.2 μ H	T24-028
L5	RF choke coil 2.2 μ H	T24-028
L7	RF choke coil 2.2 μ H	T24-028
L8	RF choke coil 2.2 μ H	T24-028
L9	RF choke coil 2.2 μ H	T24-028
L10	RF choke coil 2.2 μ H	T24-028
L11	RF choke coil 18 μ H	ATH-007
L12	RF choke coil 2.2 μ H	T24-028
L13	RF choke coil 18 μ H	ATH-007
L14	RF choke coil 2.2 μ H	T24-028
L15	RF choke coil 10 μ H	ATH-010
L16	RF choke coil 10 μ H	ATH-010
L17	RF choke coil 2.2 μ H	T24-028
L18	RF choke coil 2.2 μ H	T24-028
L19	RF choke coil 18 μ H	ATH-007
L20	RF choke coil 2.2 μ H	T24-028
L21	RF choke coil 2.2 μ H	T24-028
L22	RF choke coil 2.2 μ H	T24-028
L23	RF choke coil 2.2 μ H	T24-028
L24	RF choke coil 2.2 μ H	T24-028
L25	RF choke coil 2.2 μ H	T24-028

RESISTORS

Symbol	Description	Part No.
R1	Carbon film 1k	RD¼PS 102J
R2	Carbon film 2.4k	RD¼PS 242J
R3	Carbon film 1k	RD¼PS 102J
R4	Carbon film 1k	RD¼PS 102J
R5	Carbon film 2.7k	RD¼PS 272J
R6	Carbon film 100	RD¼PS 101J
R7	Carbon film 330	RD¼PS 331J
R8	Carbon film 1k	RD¼PS 102J
R9	Carbon film 5.6k	RD¼PS 562J
R10	Carbon film 330	RD¼PS 331J
R11	Carbon film 470	RD¼PS 471J
R12	Carbon film 56	RD¼PS 560J
R13	Carbon film 56	RD¼PS 560J
R14	Carbon film 470	RD¼PS 471J
R15	Carbon film 1k	RD¼PS 102J
R16	Carbon film 56	RD¼PS 560J
R17	Carbon film 56	RD¼PS 560J
R18	Carbon film 470	RD¼PS 471J
R19	Carbon film 3k	RD¼PS 302J
R20	Carbon film 470	RD¼PS 471J
R21	Carbon film 560	RD¼PS 561J
R22	Carbon film 5.6k	RD¼PS 562J
R23	Carbon film 47k	RD¼PS 473J
R24	Carbon film 1k	RD¼PS 102J
R25	Carbon film 1k	RD¼PS 102J
R26	Carbon film 1k	RD¼PS 102J
R27	Carbon film 1k	RD¼PS 102J
R28	Carbon film 1k	RD¼PS 102J
R29	Carbon film 1k	RD¼PS 102J
R30	Carbon film 33	RD¼PS 330J
R31	Carbon film 33	RD¼PS 330J
R32	Carbon film 1k	RD¼PS 102J
R33	Carbon film 150k	RD¼PS 154J
R34	Carbon film 150k	RD¼PS 154J
R35	Carbon film 47k	RD¼PS 473J
R36	Carbon film 820	RD¼PS 821J
R37	Carbon film 13k	RD¼PS 133J
R38	Carbon film 2.2k	RD¼PS 222J
R39	Carbon film 510	RD¼PS 511J
R40	Carbon film 8.2k	RD¼PS 822J
R41	Carbon film 82k	RD¼PS 823J
R42	Carbon film 33	RD¼PS 330J
R43	Carbon film 10k	RD¼PS 103J
R44	Carbon film 150k	RD¼PS 154J
R45	Carbon film 470	RD¼PS 471J
R46	Carbon film 100k	RD¼PS 104J
R47	Carbon film 180	RD¼PS 181J
R48	Carbon film 6.8k	RD¼PS 682J
R49	Carbon film 5.6k	RD¼PS 562J
R50	Carbon film 2.2k	RD¼PS 222J

Symbol	Description	Part No.
R51	Carbon film 68k	RD¼PS 683J
R52	Carbon film 2.2k	RD¼PS 222J
R53	Carbon film 330k	RD¼PS 334J
R54	Carbon film 100k	RD¼PS 104J
R55	Carbon film 3.3k	RD¼PS 332J
R56	Carbon film 1.8k	RD¼PS 182J
R57	Carbon film 47k	RD¼PS 473J
R58	Carbon film 33k	RD¼PS 333J
R59	Carbon film 330k	RD¼PS 334J
R60	Carbon film 2.2k	RD¼PS 222J
R61	Carbon film 330	RD¼PS 331J
R62	Carbon film 2.2k	RD¼PS 222J
R63	Carbon film 33k	RD¼PS 333J
R64	Carbon film 330k	RD¼PS 334J
R65	Carbon film 240	RD¼PS 241J
R66	Carbon film 1k	RD¼PS 102J
R67	Carbon film 3.3k	RD¼PS 332J
R68	Carbon film 1.8k	RD¼PS 182J
R69	Carbon film 2.2k	RD¼PS 222J
R70	Carbon film 150	RD¼PS 151J
R71	Carbon film 16k	RD¼PS 163J
R72	Carbon film 15k	RD¼PS 153J
R73	Carbon film 100	RD¼PS 101J
R74	Carbon film 820	RD¼PS 821J
R75	Carbon film 910	RD¼PS 911J
R76	Carbon film 56	RD¼PS 560J
R84	Carbon film 22k	RD¼PS 223J
R85	Carbon film 33k	RD¼PS 333J
R86	Carbon film 220	RD¼PS 221J
R87	Carbon film 220	RD¼PS 221J
R88	Carbon film 1k	RD¼PS 102J
R89	Carbon film 470	RD¼PS 471J
R90	Carbon film 33	RD¼PS 330J
R91	Carbon film 470	RD¼PS 471J
R92	Carbon film 330	RD¼PS 331J
R93	Carbon film 8.2k	RD¼PS 822J
R94	Carbon film 8.2k	RD¼PS 822J
R95	Carbon film 8.2k	RD¼PS 822J
R96	Carbon film 8.2k	RD¼PS 822J
R97	Carbon film 330	RD¼PS 331J
R98	Carbon film 680	RD¼PS 681J
R99	Carbon film 1.5k	RD¼PS 152J
R100	Carbon film 200	RD¼PS 201J
R101	Carbon film 150	RD¼PS 151J
R102	Carbon film 5.6k	RD¼PS 562J
R103	Carbon film 220	RD¼PS 221J
R104	Carbon film 390	RD¼PS 391J
R105	Carbon film 10k	RD¼PS 103J
R106	Carbon film 10k	RD¼PS 103J
R107	Carbon film 1k	RD¼PS 102J

Symbol	Description	Part No.
R108	Carbon film 82k	RD½PS 823J
R109	Carbon film 47	RD½PS 470J
VR1	Semi-fixed 4.7k	C92-051
VR2	Semi-fixed 6.8k	ACP-023
VR3	Semi-fixed 47k	C92-048
VR4	Semi-fixed 100k	C92-047
VR5	Semi-fixed 68k	ACP-002
VR6	Variable resistor 10k (OUTPUT LEVEL)	ACV-178

CAPACITORS

Symbol	Description	Part No.
C1	Ceramic 0.75p 500V	CGB R75J 500
C2	Ceramic 0.82p 500V	CGB R82J 500
C3	Ceramic 2.7p 500V	CGB 2R7J 500
C4	Ceramic 0.04 25V	CKDYF 403Z 25
C5	Ceramic 0.04 25V	CKDYF 403Z 25
C6	Ceramic 0.01 50V	CKDYF 103Z 50
C7	Ceramic 0.04 50V	CKDYF 403Z 50
C8	Ceramic 0.04 50V	CKDYF 403Z 50
C9	Ceramic 0.04 50V	CKDYF 403Z 50
C10	Ceramic 0.04 50V	CKDYF 403Z 50
C11	Ceramic 0.01 50V	CKDYF 103Z 50
C12	Ceramic 0.047 25V	CKDBC 473Z 25
C13	Ceramic 0.04 50V	CKDYF 403Z 50
C14	Ceramic 15p 50V	CCDSL 150K 50
C15	Ceramic 0.047 25V	CKDBC 473Z 25
C16	Ceramic 0.01 50V	CKDYF 103Z 50
C17	Ceramic 0.04 50V	CKDYF 403Z 50
C18	Ceramic 0.04 50V	CKDYF 403Z 50
C19	Ceramic 0.047 25V	CKDBC 473Z 25
C20	Ceramic 0.04 50V	CKDYF 403Z 50
C21	Ceramic 0.04 50V	CKDYF 403Z 50
C22	Ceramic 0.04 50V	CKDYF 403Z 50
C23	Ceramic 0.04 50V	CKDYF 403Z 50
C24	Ceramic 0.04 50V	CKDYF 403Z 50
C25	Ceramic 0.04 50V	CKDYF 403Z 50
C26	Ceramic 0.04 50V	CKDYF 403Z 50
C27	Ceramic 0.04 50V	CKDYF 403Z 50
C28	Ceramic 0.04 50V	CKDYF 403Z 50
C29	Ceramic 0.04 50V	CKDYF 403Z 50
C30	Ceramic 0.04 50V	CKDYF 403Z 50
C31	Ceramic 0.04 50V	CKDYF 403Z 50
C32	Ceramic 33 50V	CCDCH 330J 50
C33	Ceramic 15 50V	CCDCH 150J 50
C34	Ceramic 0.04 50V	CKDYF 403Z 50
C35	Ceramic 0.04 50V	CKDYF 403Z 50
C36	Ceramic 33p 50V	CCDSL 330K 50
C37	Ceramic 33p 50V	CCDSL 330K 50
C38	Electrolytic 330 16V	CEA 331P 16

Symbol	Description	Part No.
C39	Ceramic 47p 50V	CCDSL 470K 50
C40	Ceramic 47p 50V	CCDSL 470K 50
C41	Electrolytic 22 16V	CEANL 220P 16
C42	Electrolytic 330 16V	CEA 331P 16
C43	Electrolytic 100 10V	CEA 101P 10
C44	Electrolytic 47 16V	CEANL 470P 16
C45	Electrolytic 220 16V	CEA 221P 16
C46	Electrolytic 2.2 50V	CEA 2R2P 50
C47	Ceramic 0.01 50V	CKDYF 103Z 50
C48	Ceramic 0.01 50V	CKDYF 103Z 50
C49	Ceramic 0.047 25V	CKDBC 473Z 25
C50	Ceramic 33p 50V	CCDSL 330K 50
C51	Electrolytic 2.2 50V	CEA 2R2P 50
C52	Electrolytic 1 50V	CEA 010P 50
C53	Ceramic 0.01 50V	CKDYF 103Z 50
C54	Ceramic 0.047 25V	CKDBC 473Z 25
C55	Ceramic 0.047 50V	CKDBC 473Z 25
C56	Electrolytic 2.2 50V	CEA 2R2P 50
C57	Electrolytic 2.2 50V	CEA 2R2P 50
C58	Ceramic 0.047 25V	CKDBC 473Z 25
C59	Electrolytic 1 50V	CEA 010P 50
C60	Ceramic 0.01 50V	CKDYF 103Z 50
C61	Ceramic 33p 50V	CCDSL 330K 50
C62	Ceramic 0.01 50V	CKDYF 103Z 50
C63	Ceramic 47p 50V	CCDSL 470K 50
C64	Ceramic 0.01 50V	CKDYF 103Z 50
C65	Ceramic 0.01 50V	CKDYF 103Z 50
C66	Ceramic 0.04 50V	CKDYF 403Z 50
C67	Ceramic 0.04 50V	CKDYF 403Z 50
C68	Ceramic 0.04 50V	CKDYF 403Z 50
C69	Ceramic 0.04 50V	CKDYF 403Z 50
C70	Ceramic 0.04 50V	CKDYF 403Z 50
C71	Ceramic 0.04 50V	CKDYF 403Z 50
C72	Ceramic 0.01 50V	CKDYF 103Z 50
C73	Ceramic 0.047 25V	CKDBC 473Z 25
C74	Ceramic 0.047 25V	CKDBC 473Z 25
C75	Electrolytic 1 50V	CEA 010P 50
C76	Ceramic 15p 50V	CCDSL 150K 50
C77	Mylar 0.01 50V	CQMA 103J 50
C78	Electrolytic 220 6V	CEA 221P 6
C79	Ceramic 0.01 50V	CKDYF 103Z 50
C80	Ceramic 10 50V	CCDSH 100F 50
C81	Ceramic 5p 50V	CCDSH 050D 50
C82	Polystyrene 410p 50V	CQSA 411J 50
C83	Ceramic 15p 50V	CCDWK 150K 50
C84	Electrolytic 10 16V	CEA 100P 16
C85	Ceramic 0.01 50V	CKDYF 103Z 50
C86	Ceramic 0.01 50V	CKDYF 103Z 50
C87	Ceramic 0.001 50V	CKDYF 102Z 50
C88	Ceramic 0.01 50V	CKDYF 103Z 50
C89	Ceramic 33p 50V	CCDSL 330K 50
C90	Ceramic 0.01 50V	CKDYF 103Z 50

Symbol	Description	Part No.
C91	Electrolytic 4.7 35V	CEA 4R7P 35
C92	Ceramic 0.047 25V	CKDBC 473Z 25
C93	Electrolytic 3.3 50V	CEA 3R3P 50
C94	Mylar 0.022 50V	CQMA 223J 50
C95	Mylar 0.01 50V	CQMA 103J 50
C96	Electrolytic 22 16V	CEA 220P 16
C97	Ceramic 100p 50V	CCDSL 101K 50
C98	Ceramic 0.0012 50V	CKDYB 122K 50
C99	Electrolytic 100 16V	CEA 101P 16
C100	Ceramic 0.04 50V	CKDYF 403Z 50
C101	Ceramic 0.04 50V	CKDYF 403Z 50
C102	Electrolytic 33 16V	CEA 330P 16
TC1	Film trimmer	ACM-008 (ACH-002)
TC2	Film trimmer	ACM-008 (ACH-002)
TC3	Film trimmer	ACM-008 (ACH-002)

SWITCHES

Symbol	Description	Part No.
S1	Rotary switch (FUNCTION)	ASD-063
S2	Lever switch (FM MUTING)	ASK-111
S3	Lever switch (MODE)	ASK-113
S4	Lever switch (IF BAND)	ASK-109

OTHERS

Symbol	Description	Part No.
	Flange screw	ABA-078
	Screw 3x6	ABA-116
	Nut	ABN-027
	Nut	ABN-026

* Within the same assembly, use FM ceramic filters ($F_1 - F_5$) and SAW filters with identical ranks. The ranks are indicated in red, blue, orange, black, and white. The FM combination filter (ATF-041) is a combination of identically ranked $F_1 - F_5$ (ATF-040) and F_6 (ATF-035).

12.4 MPX AF ASSEMBLY (AWD-009)

A

B

C

D

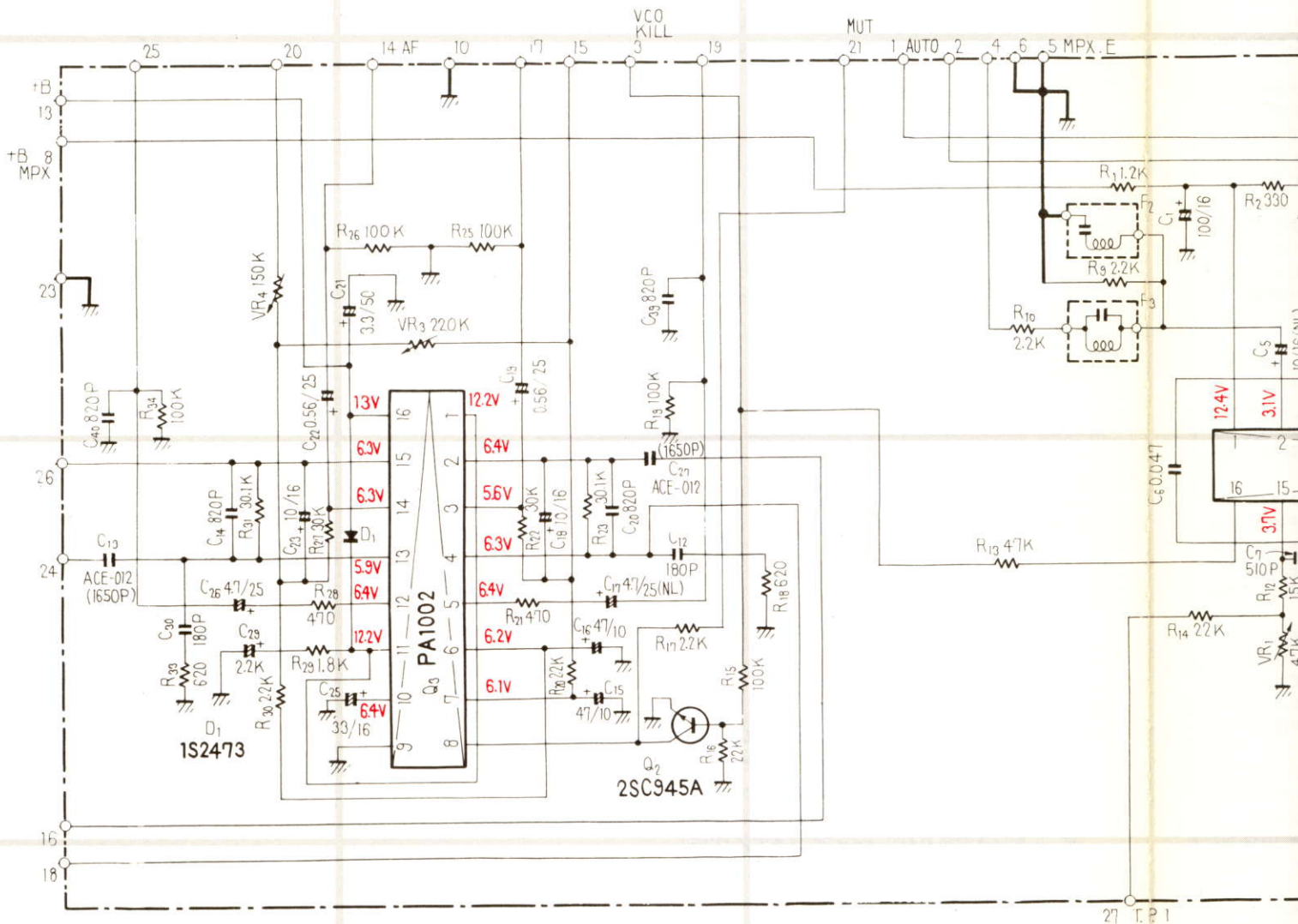

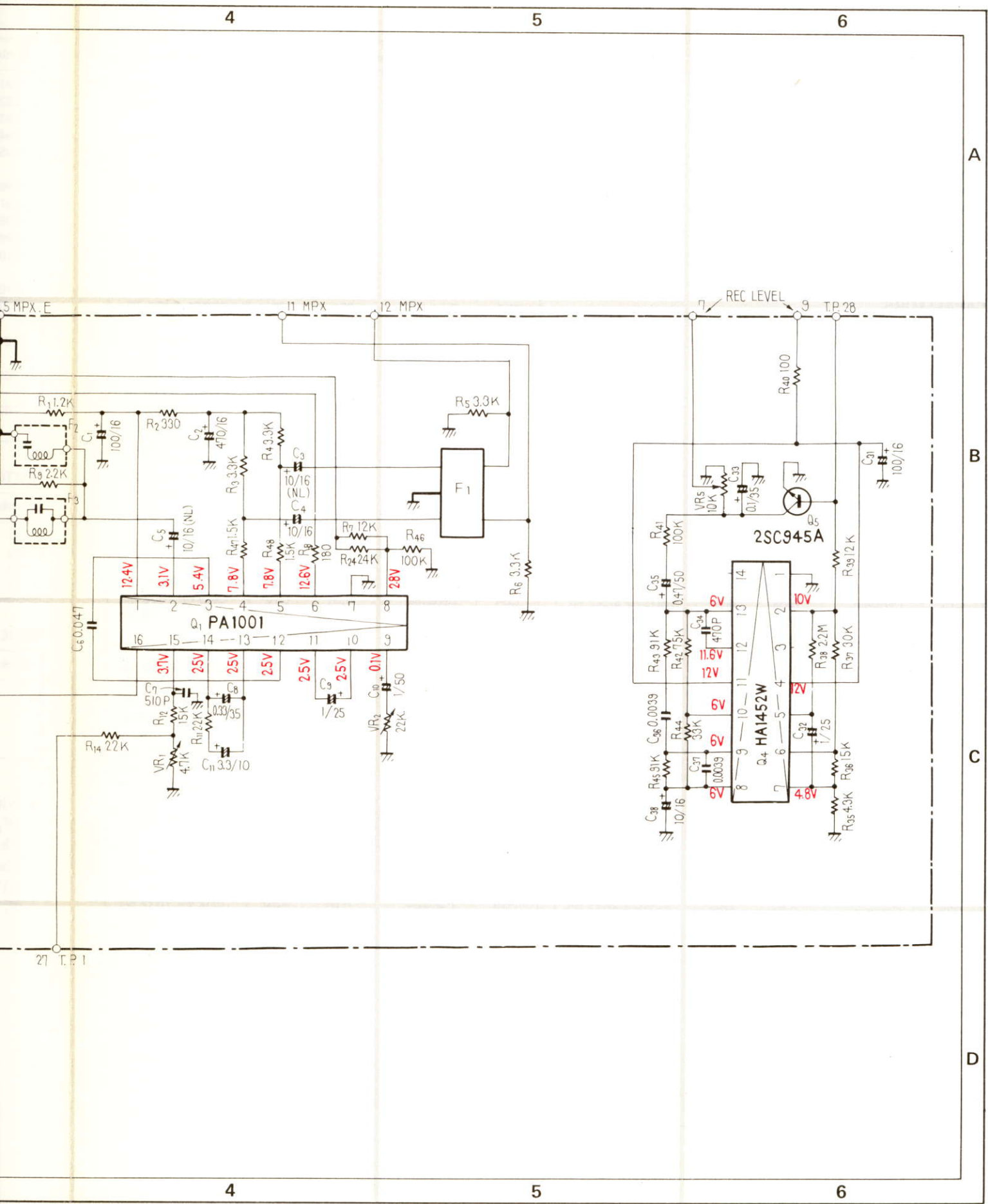

Foil side

A

B

C

D

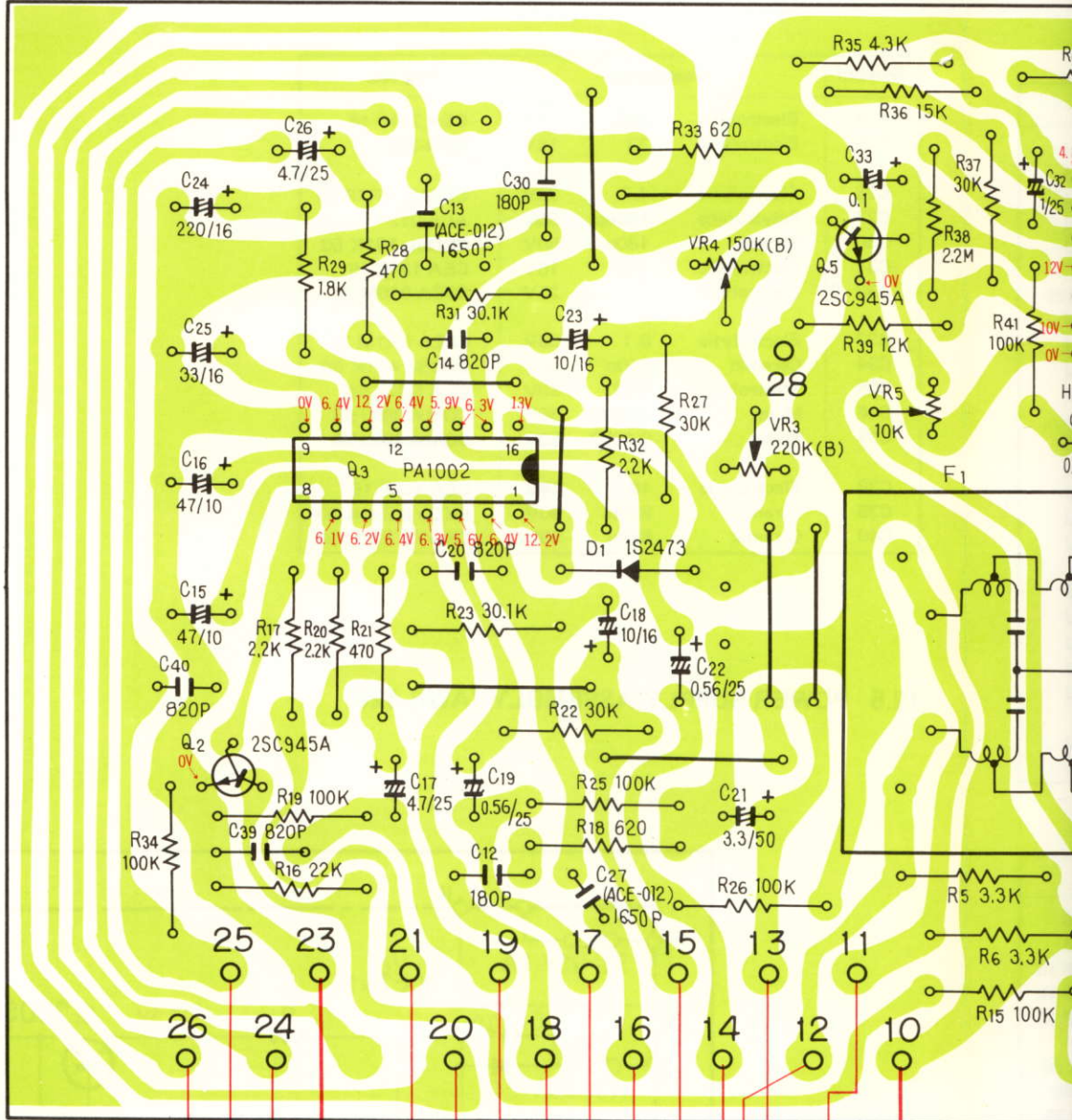

+B

1

2

3

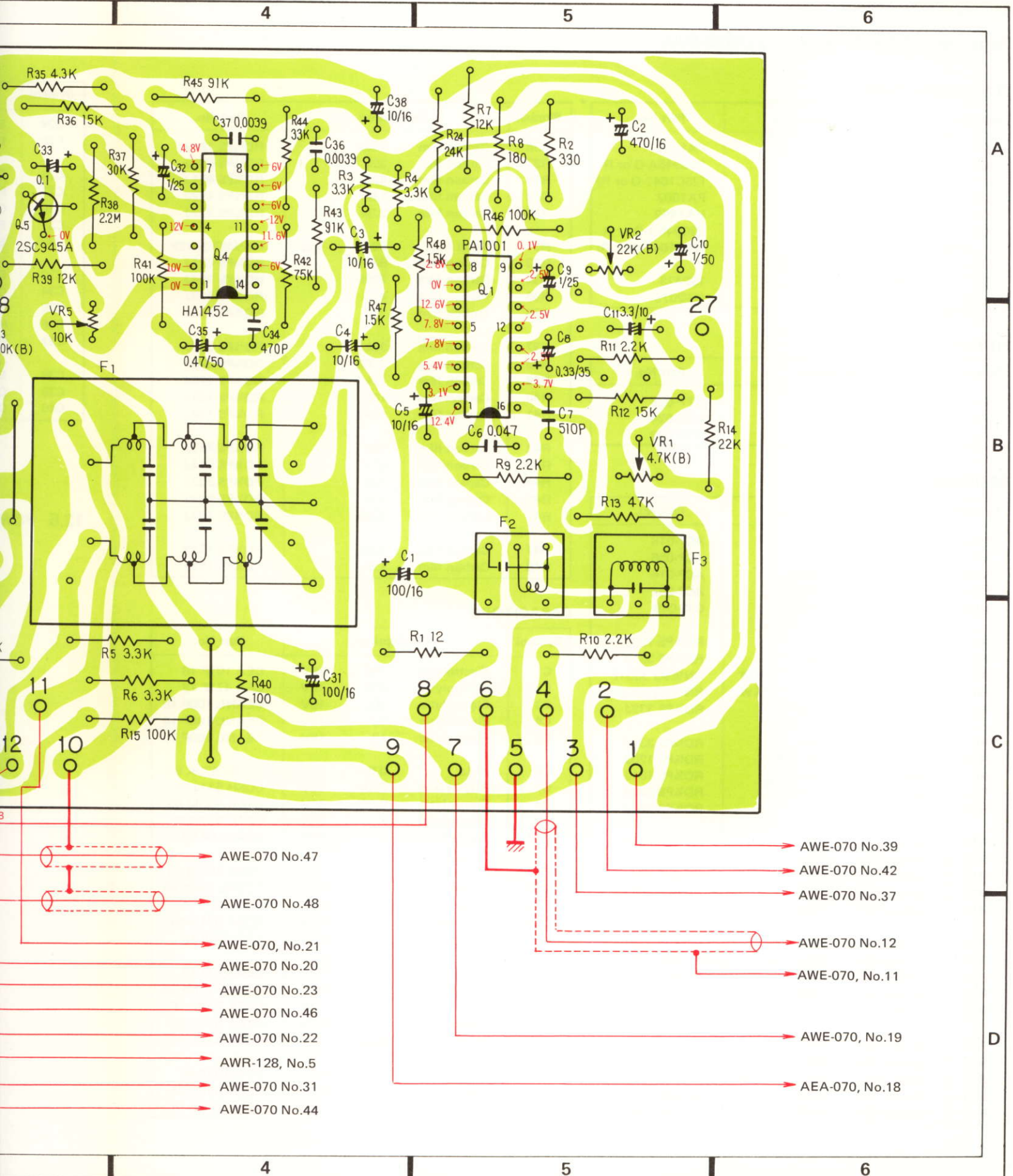

AWE-070 No.47

AWE-070 No.48

AWE-070, No.21

AWE-070 No.20

AWE-070 No.23

AWE-070 No.46

AWE-070 No.22

AWR-128, No.5

AWE-070 No.31

AWE-070 No.44

AWE-070 No.39

AWE-070 No.42

AWE-070 No.37

AWE-070 No.12

AWE-070, No.11

AWE-070, No.19

AEA-070, No.18

A

B

C

D

4

5

6

Parts List of MPX AF Assembly (AWD-009)

SEMICONDUCTORS

Symbol	Description	Part No.
Q1	IC	PA1001
Q2	Transistor	2SC945A-Q or R (2SC1647-Q or R)
Q3	IC	PA1002
Q4	IC	HA1452
Q5	Transistor	2SC945A-Q or R (2SC1647-Q or R)
D1	Diode	1S2473 (1S2076)

FILTERS

Symbol	Description	Part No.
F1	Low pass filter	ATF-028
F2	Anti-birdy filter	ATF-024
F3	Anti-birdy filter	ATF-023

RESISTORS

Symbol	Description	Part No.
VR1	Semi-fixed (4.7k)	ACP-018
VR2	Semi-fixed (22k)	ACP-056
VR3	Semi-fixed (220k)	ACP-016
VR4	Semi-fixed (150k)	ACP-057
VR5	Semi-fixed (10k)	C92-049
R1	Carbon film 12	RD¼PS 120J
R2	Carbon film 330	RD¼PS 331J
R3	Metal film 3.3k ½W	RN½SQ 3301F
R4	Metal film 3.3k ½W	RN½SQ 3301F
R5	Carbon film 3.3k	RD¼PS 332J
R6	Carbon film 3.3k	RD¼PS 332J
R7	Carbon film 12k	RD¼PS 123J
R8	Carbon film 180	RD¼PS 181J
R9	Carbon film 2.2k	RD¼PS 222J
R10	Carbon film 2.2k	RD¼PS 222J
R11	Carbon film 2.2k	RD¼PS 222J
R12	Carbon film 15k	RD¼PS 153J
R13	Carbon film 47k	RD¼PS 473J
R14	Carbon film 22k	RD¼PS 223J
R15	Carbon film 100k	RD¼PS 104J
R16	Carbon film 22k	RD¼PS 223J
R17	Carbon film 2.2k	RD¼PS 222J
R18	Carbon film 620	RD¼PS 621J
R19	Carbon film 100k	RD¼PS 104J
R20	Carbon film 2.2k	RD¼PS 222J
R21	Carbon film 470	RD¼PS 471J
R22	Carbon film 30k	RD¼PS 303J
R23	Metal film 30.1k ½W	RN½SQ 3012F
R24	Carbon film 24k	RD¼PS 243J
R25	Carbon film 100k	RD¼PS 104J

Symbol	Description	Part No.
R26	Carbon film 100k	RD¼PS 104J
R27	Carbon film 30k	RD¼PS 303J
R28	Carbon film 470	RD¼PS 471J
R29	Carbon film 1.8k	RD¼PS 182J
R30	Carbon film 2.2k	RD¼PS 222J
R31	Metal film 30.1k ½W	RN½SQ 3012F
R33	Carbon film 620	RD¼PS 621J
R34	Carbon film 100k	RD¼PS 104J
R35	Carbon film 4.3k	RD¼PS 432J
R36	Carbon film 15k	RD¼PS 153J
R37	Carbon film 30k	RD¼PS 303J
R38	Carbon film 2.2M	RD¼PS 225J
R39	Carbon film 12k	RD¼PS 123J
R40	Carbon film 100	RD¼PS 101J
R41	Carbon film 100k	RD¼PS 104J
R42	Carbon film 75k	RD¼PS 753J
R43	Carbon film 91k	RD¼PS 913J
R44	Carbon film 33k	RD¼PS 333J
R45	Carbon film 91k	RD¼PS 913J
R46	Carbon film 100k	RD¼PS 104J
R47	Carbon film 1.5k	RD¼PS 152J
R48	Carbon film 1.5k	RD¼PS 152J

CAPACITORS

Symbol	Description	Part No.
C1	Electrolytic 100 16V	CEA 101P 16
C2	Electrolytic 470 16V	CEA 471P 16
C3	Electrolytic 10 16V	CEANL 100P 16
C4	Electrolytic 10 16V	CEANL 100P 16
C5	Electrolytic 10 16V	CEANL 100P 16
C6	Mylar 0.047 50V	CQMA 473K 50
C7	Polystyrene 510p 50V	CQSH 511J 50
C8	Electrolytic 0.33 35V	CSZA R33M 35
C9	Electrolytic 1 25V	CSZA 010M 25
C10	Electrolytic 1 50V	CEA 010P 50
C11	Electrolytic 3.3 10V	CSZA 3R3M 10
C12	Ceramic 180p 50V	CCDSL 181K 50
C13	Polystyrene 1650p 50V	ACE-012
C14	Polystyrene 820p 50V	CQSA 821G 50
C15	Electrolytic 47 10V	CEA 470P 10
C16	Electrolytic 47 10V	CEA 470P 10
C17	Electrolytic 4.7 25V	CEANL 4R7P 25
C18	Electrolytic 10 16V	CSZA 100M 16
C19	Electrolytic 0.56 35V	CSZA R56K 35
C20	Polystyrene 820p 50V	CQSA 821G 50
C21	Electrolytic 3.3 50V	CEA 3R3P 50
C22	Electrolytic 0.56 35V	CSZA R56K 35
C23	Electrolytic 10 16V	CSZA 100M 16

Symbol	Description	Part No.
C24	Electrolytic 220 16V	CEA 221P 16
C25	Electrolytic 33 16V	ACH-321
C26	Electrolytic 4.7 25V	CEANL 4R7P 25
C27	Polystyrene 1650p 50V	ACE-012
C30	Ceramic 180p 50V	CCDSL 181K 50
C31	Electrolytic 100 16V	CEA 101P 16
C32	Electrolytic 1 25V	CSZA 010M 25
C33	Electrolytic 0.1 35V	CSZA 0R1M 35
C34	Ceramic 470p 50V	CCDSL 471K 50
C35	Electrolytic 0.47 50V	CEA R47P 50
C36	Mylar 0.0039 50V	CQMA 392J 50
C37	Mylar 0.0039 50V	CQMA 392J 50
C38	Electrolytic 10 16V	CEA 100P 16
C39	Ceramic 820p 50V	CKDYB 821K 50
C40	Ceramic 820p 50V	CKDYB 821K 50

12.5 POWER SUPPLY ASSEMBLY (AWR-128)

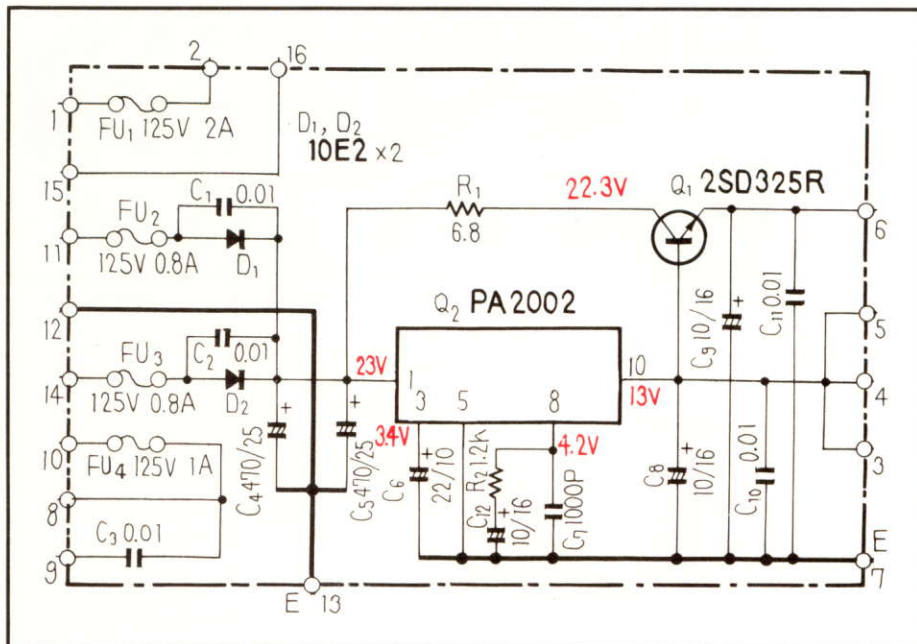

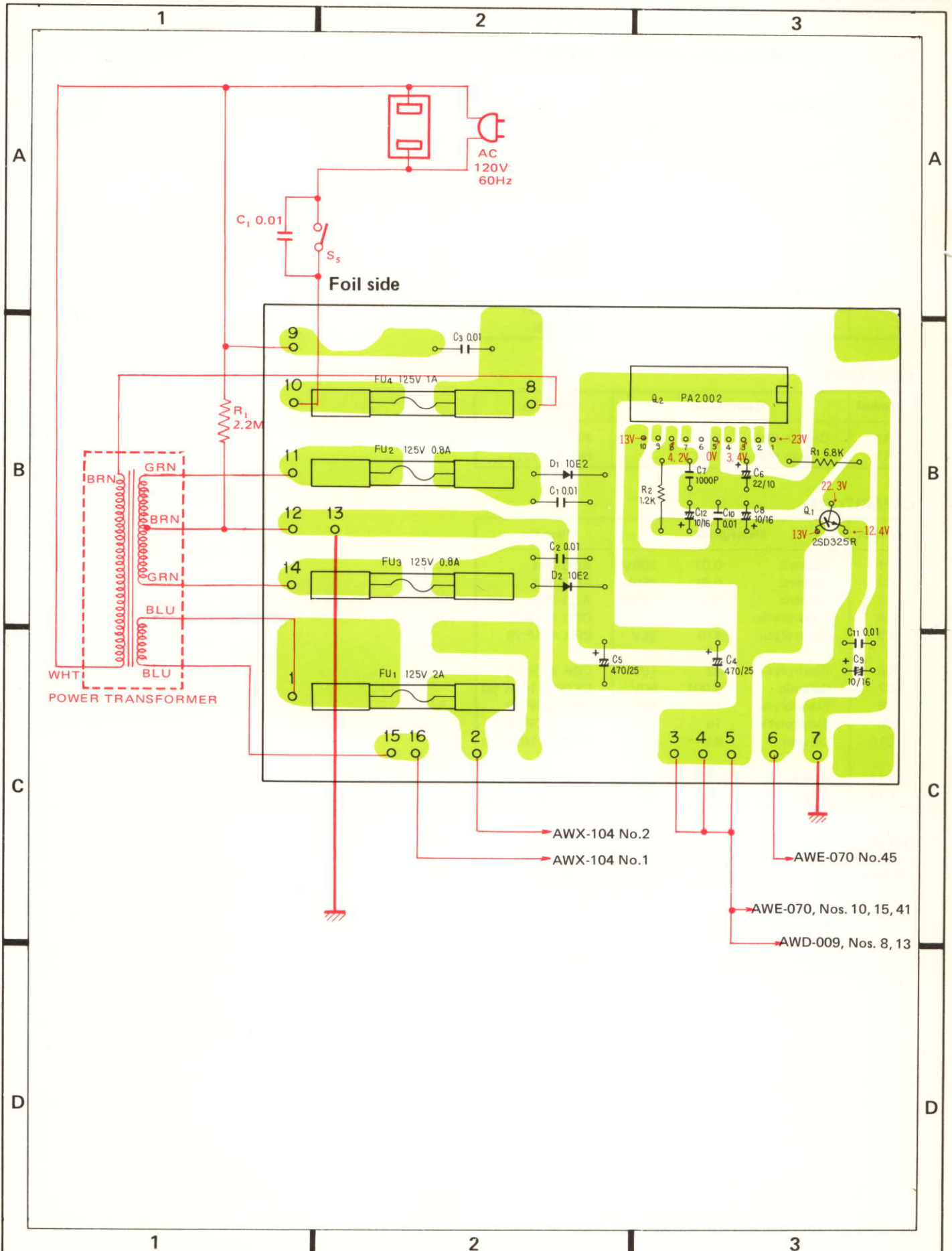

Parts List of Power Supply Assembly (AWR-128)

SEMICONDUCTORS

Symbol	Description	Part No.
Q1	Transistor	2SD325R-E or D (2SD234-O or R)
Q2	IC	PA2002
D1	Diode	10E2 (SIB01-02) (1S1886)
D2	Diode	10E2 (SIB01-02) (1S1886)

RESISTORS

Symbol	Description	Part No.
R1	Carbon film 6.8	RD¼PS 6R8J
R1	Carbon film 1.2k	RD¼PS 122J

CAPACITORS

Symbol	Description	Part No.
C1	Ceramic 0.01 150V	ACG-004
C2	Ceramic 0.01 150V	ACG-004
C3	Ceramic 0.01 125V	ACG-003
C4	Electrolytic 470 25V	CEA 471P 25
C5	Electrolytic 470 25V	CEA 471P 25
C6	Electrolytic 22 10V	CEA 220P 10
C7	Ceramic 0.001 50V	CKDYB 102K 50
C8	Electrolytic 10 16V	CEA 100P 16
C9	Electrolytic 10 16V	CEA 100P 16
C10	Ceramic 0.01 50V	CKDYB 103K 50
C11	Ceramic 0.01 50V	CKDYB 103K 50
C12	Electrolytic 10 16V	CEA 100P 16

OTHERS

Symbol	Description	Part No.
	Fuse clip	AKR-013
	Fuse clip	AKR-030
	Heat sink	ANH-117
	Cover	AEC-279

AM/FM STEREO TUNER
TX-9500II
KC, HG, S

Additional

Service Manual

NOTES:

- This leaflet provides the description of the parts applies only to the TX-9500II/KC, HG, S types. For detailed please refer to the service manual of TX-9500II/KU type (p.5~p.52).
- The specifications for "KC", "HG" and "S" types are same as "KU" type except for following sections.

Power Requirements:

KC type	Same as KU type
HG type	220V and 240V (Switchable) 50Hz
S type	110V, 120V, 220V and 240V (Switchable) 50/60Hz

 **PIONEER®**

1. CONTRAST OF MISCELLANEOUS PARTS

P.C. BOARD ASSEMBLIES

Symbol	Description	Part No.			Remarks
		KU, KC types	S type	HG type	
	MPX AF assembly	AWD-009	AWD-010	AWD-008	
	Power supply assembly	AWR-128 (KU) AWR-129 (KC)	AWR-131	AWR-130	
	Switch assembly	AWX-113	

TRANSFORMER

Symbol	Description	Part No.			Remarks
		KU, KC types	S type	HG type	
T3	Power transformer	ATT-347	ATT-349	ATT-348	

FUSES

Symbol	Description	Part No.			Remarks
		KU, KC types	S type	HG type	
FU1	Fuse 2A (Secondary)	AEK-103	AEK-017	
	Fuse 500mA (Primary)	AEK-107	
FU2	Fuse 800mA (Secondary)	AEK-111	AEK-031	
FU3	Fuse 800mA (Secondary)	AEK-111	AEK-031	
FU4	Fuse 1 A (Primary)	AEK-106	
	Fuse 500mA (Primary)	AEK-401	

SWITCHES

Symbol	Description	Part No.			Remarks
		KU, KC types	S type	HG type	
S5	Lever switch (POWER)	ASK-124	ASK-128	ASK-127	
S6	Slide switch (DE-EMPHASIS)	ASH-016	ASH-017	
	Plug in selector	AKR-031	4 position
	(Line voltage selector)	AKX-037	2 position

CAPACITORS

Symbol	Description			Part No.			Remarks
				KU, KC types	S type	HG type	
C1	Ceramic	0.01	125V	ACG-014 (KC)	
	Ceramic	0.01	250V	ACG-001 (KU)	ACG-001	

RESISTOR

Symbol	Description			Part No.			Remarks
				KU, KC types	S type	HG type	
R1	Carbon film	2.2M	½W	RD½PS 225J	

OTHERS

Symbol	Description			Part No.			Remarks
				KU, KC types	S type	HG type	
	Terminal (ANTENNA)			AKA-002	AKA-002	AKA-007	
	AC socket (OUTLET)			AKP-002	AKP-002	
	AC socket (INLET)			AKP-008	
	AC power cord			ADG-005	ADG-016	
	Packing case			AHD-439 (KU) AHD-440 (KC)	AHD-439	AHD-441	
	Vinyl pouch			AHG-023	AHG-023	
	Operating instructions (English)			ARB-207	ARB-219	ARB-218	
	Operating instructions (Germany/French)			ARD-107	
	Accessory fuse 1A			AEK-106	
	Accessory fuse 500mA			AEK-107	
	Vinyl pouch			E11-033	

2. KC TYPE

2.1 SCHEMATIC DIAGRAM AND MISCELLANEOUS PARTS LIST

Miscellaneous Parts List

NOTE:

- Capacitors: in μF unless otherwise noted p:pF
- Resistors: in Ω , $\frac{1}{4}W$ unless otherwise noted k:k Ω , M:M Ω

SWITCHES

Symbol	Description	Part No.
S5	Lever switch (POWER)	ASK-124
S6	Slide switch (DE-EMPHASIS)	ASH-016

TRANSFORMERS AND COIL

Symbol	Description	Part No.
T1	Ferrite balun	T22-025
T2	Bar antenna	ATB-507
T3	Power transformer	ATT-347
L1	RF choke coil	T24-030

LAMPS

Symbol	Description	Part No.
PL1	Lamp (Wedge type) 8V, 300mA	AEL-029
PL2	Lamp (Wedge type) 8V, 300mA	AEL-029
PL3	Lamp (Wedge type) 8V, 300mA	AEL-029
PL4	Lamp (Wedge type) 8V, 300mA	AEL-029
PL5	Lamp with wire 8V, 50mA	AEL-072
PL6	Lamp with wire 6V, 30mA	AEL-080
PL7	Lamp with wire 6V, 30mA	AEL-079
PL8	Lamp with wire 6V, 30mA	AEL-079

FUSES

Symbol	Description	Part No.
FU1	Fuse 2A (Secondary)	AEK-103
FU2	Fuse 800mA (Secondary)	AEK-111
FU3	Fuse 800mA (Secondary)	AEK-111
FU4	Fuse 1A (Primary)	AEK-106

RESISTOR

Symbol	Description	Part No.
R1	Carbon film 2.2M $\frac{1}{4}W$	RD $\frac{1}{2}$ PS 225J

CAPACITORS

Symbol	Description	Part No.
C1	Ceramic 0.01 125V	ACG-014
C2	Ceramic 0.04 50V	CKDYF 403Z 50

4

5

6

TUNER ASS'Y AWE-070

IF T.P

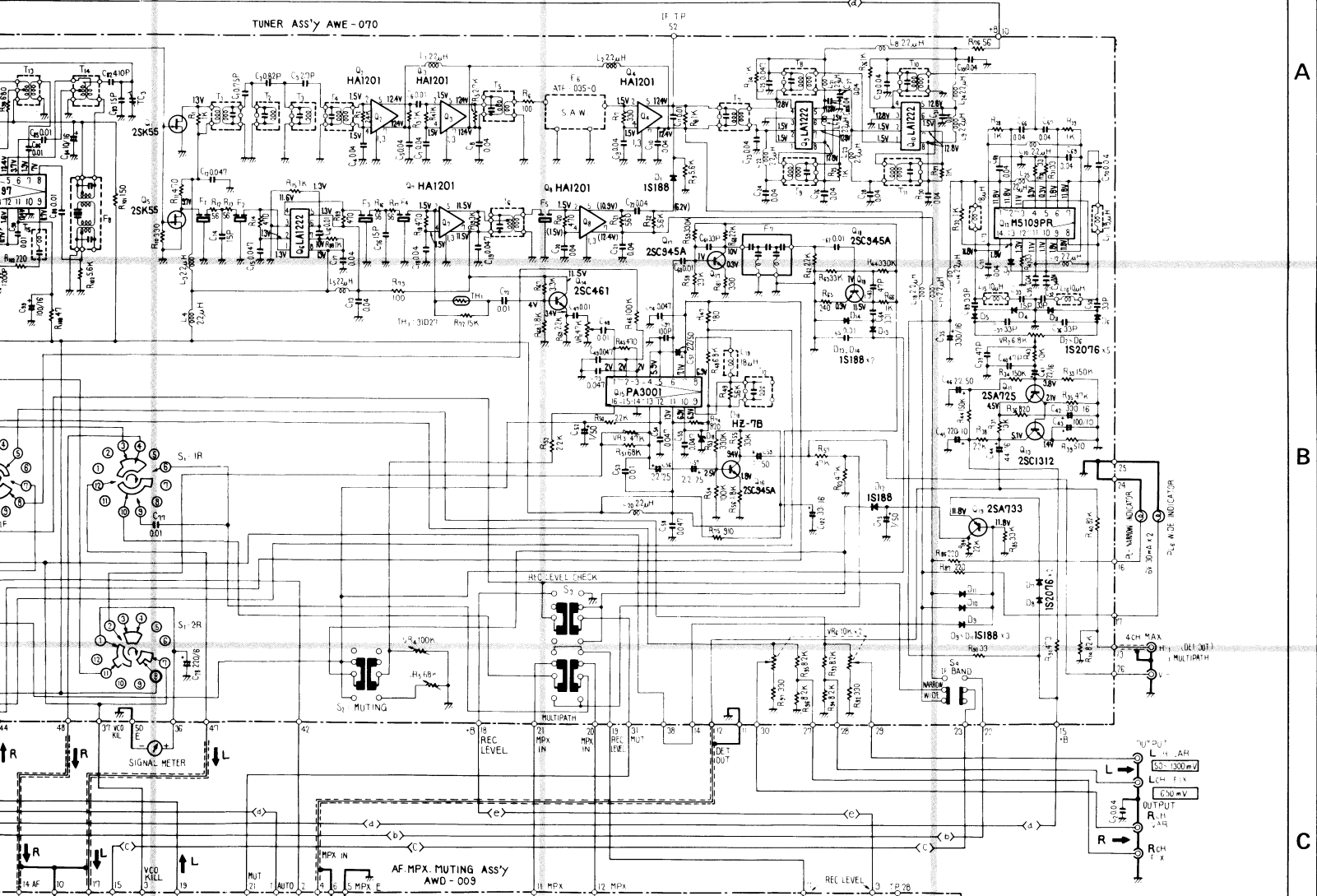

A

B

C

D

4

5

6

AF MPX MUTING ASS'Y AWD-003

IF T.P

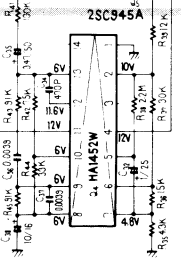

2.2 POWER SUPPLY ASSEMBLY (AWR-129)

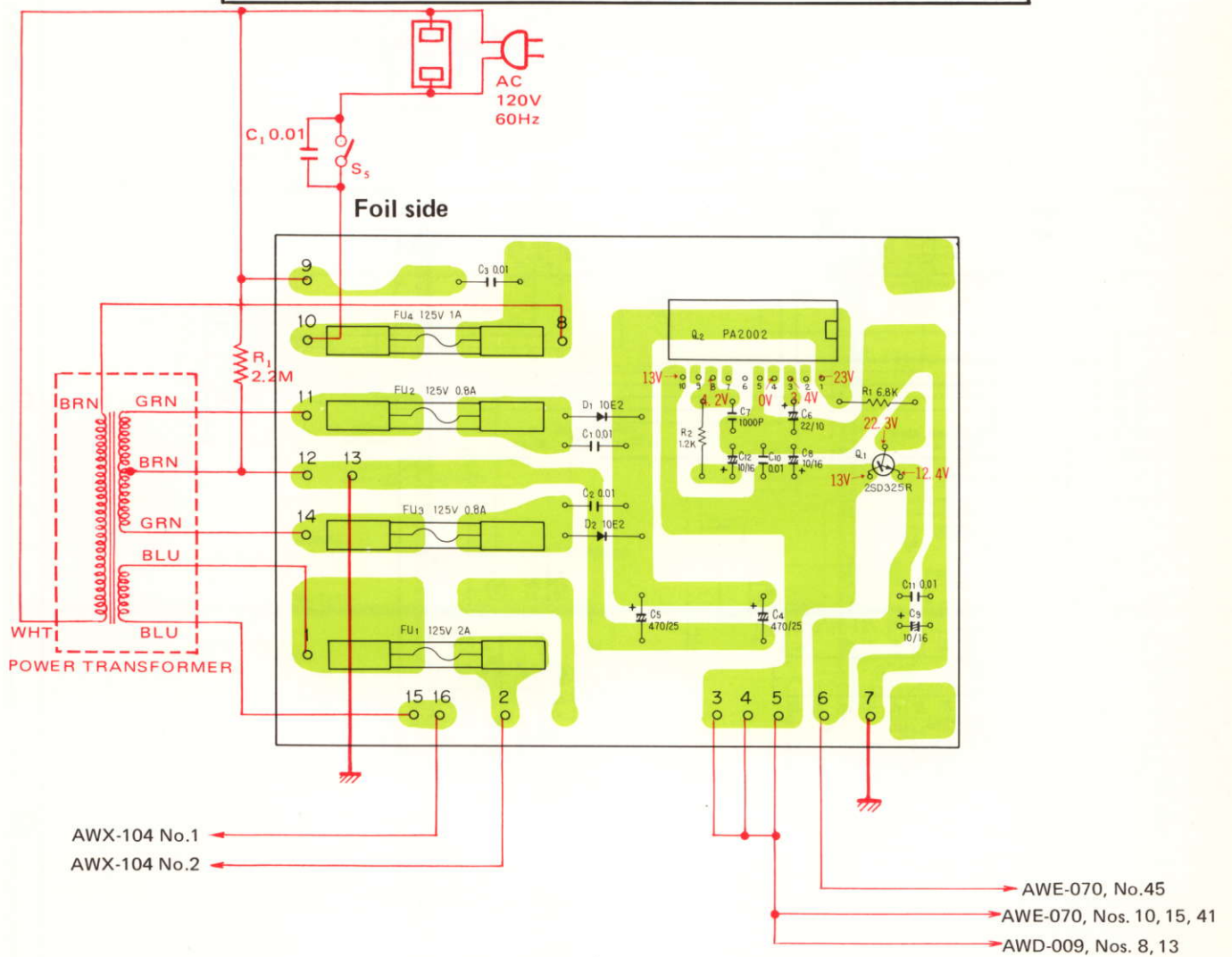
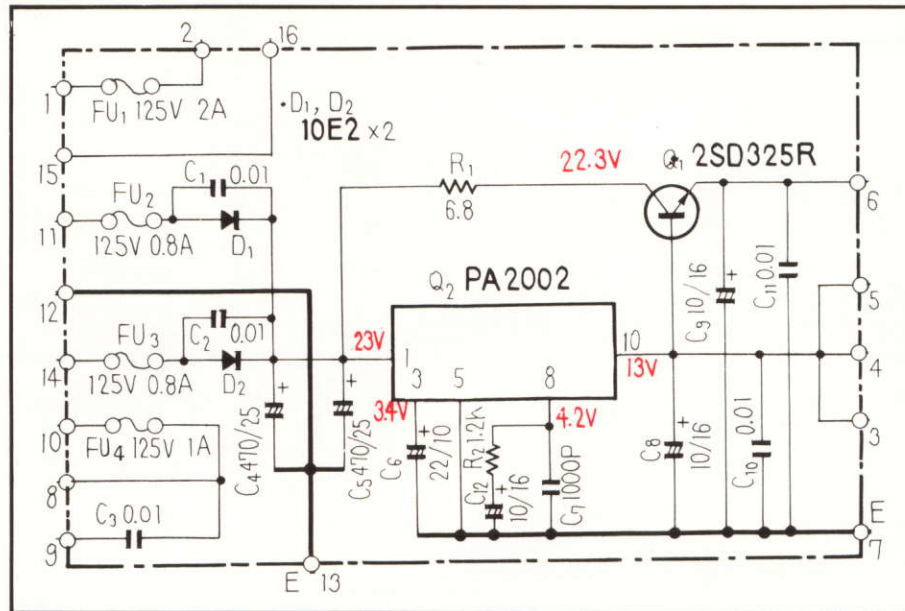

Parts List of Power Supply Assembly (AWR-129)

SEMICONDUCTORS

Symbol	Description	Part No.
Q1	Transistor	2SD325R-E or D (2SD234-O or R)
Q2	IC	PA 2002
D1	Diode	10E 2 (S1B01-02) (1S1886)
D2	Diode	10E 2 (S1B01-02) (1S1886)

RESISTORS

Symbol	Description	Part No.
R1	Carbon film 6.8	RD¼PS 6R8J
R2	Carbon film 1.2k	RD¼PS 122J

CAPACITORS

Symbol	Description	Part No.
C1	Ceramic 0.01 150V	ACG-004
C2	Ceramic 0.01 150V	ACG-004
C3	Ceramic 0.01 125V	ACG-014
C4	Electrolytic 470 25V	CEA 471P 25
C5	Electrolytic 470 25V	CEA 471P 25
C6	Electrolytic 22 10V	CEA 220P 10
C7	Ceramic 0.001 50V	CKDYB 102K 50
C8	Electrolytic 10 16V	CEA 100P 16
C9	Electrolytic 10 16V	CEA 100P 16
C10	Ceramic 0.01 50V	CKDYB 103K 50
C11	Ceramic 0.01 50V	CKDYB 103K 50
C12	Electrolytic 10 16V	CEA 100P 16

OTHERS

Symbol	Description	Part No.
	Fuse clip	AKR-013
	Fuse clip	AKR-030
	Heat sink	ANH-117
	Cover	AEC-279

2.3 PACKING

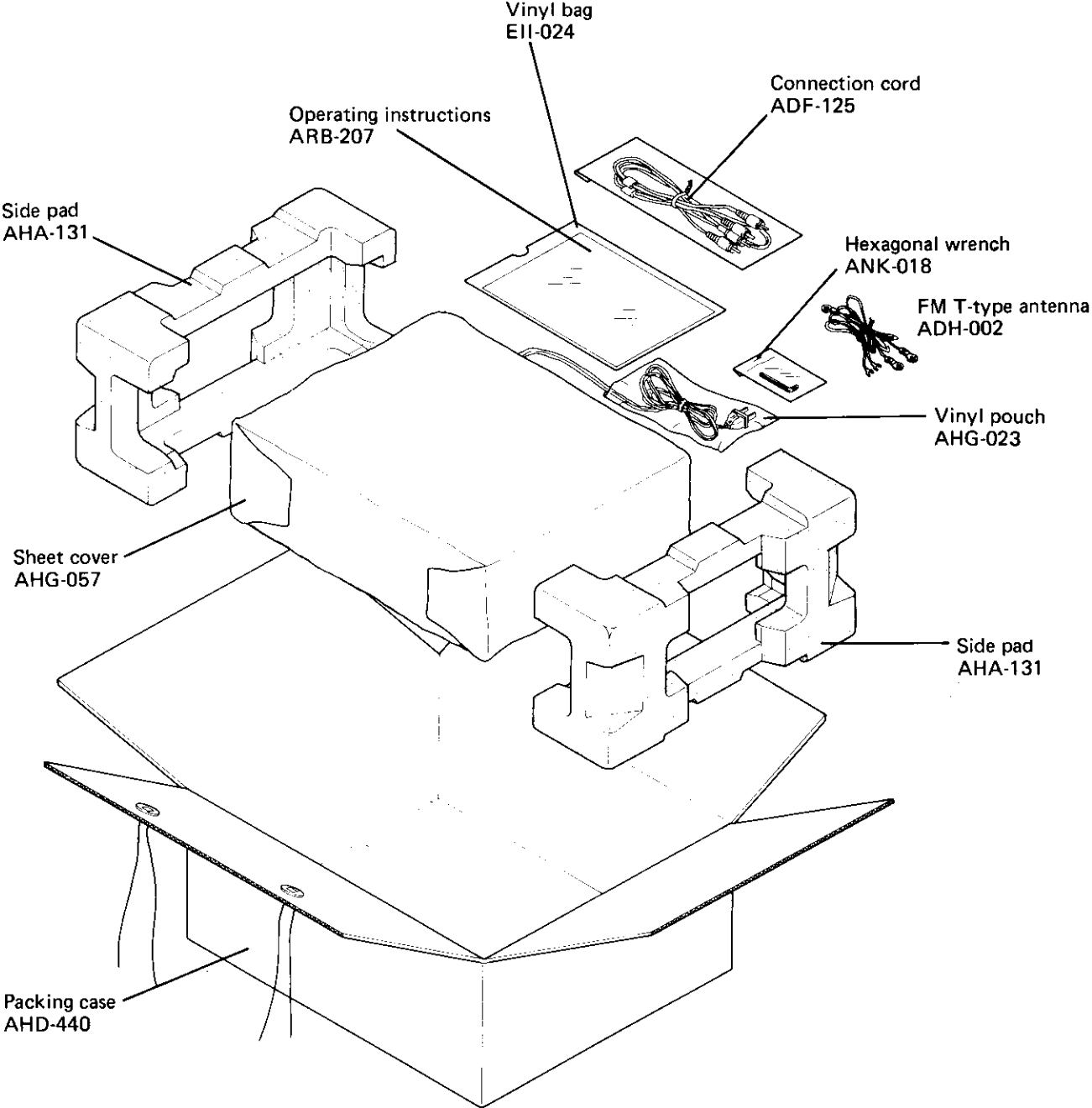

3. HG TYPE

3.1 SCHEMATIC DIAGRAM AND MISCELLANEOUS PARTS LIST

Miscellaneous Parts List

NOTE:

- Capacitors: in μF unless otherwise noted p:pF
- Resistors: in Ω , $\frac{1}{4}W$ unless otherwise noted k:k Ω , M:M Ω

SWITCHES

Symbol	Description	Part No.
S5	Lever switch (POWER) Plug in selector (Line voltage selector)	ASK-127 AKX-037

TRANSFORMERS AND COIL

Symbol	Description	Part No.
T1	Ferrite balun	T22-025
T2	Bar antenna	ATB-507
T3	Power transformer	ATT-348
L1	RF choke coil	T24-030

LAMPS

Symbol	Description	Part No.
PL1	Lamp (Wedge type) 8V, 300mA	AEL-029
PL2	Lamp (Wedge type) 8V, 300mA	AEL-029
PL3	Lamp (Wedge type) 8V, 300mA	AEL-029
PL4	Lamp (Wedge type) 8V, 300mA	AEL-029
PL5	Lamp with wire 8V, 50mA	AEL-072
PL6	Lamp with wire 6V, 30mA	AEL-080
PL7	Lamp with wire 6V, 30mA	AEL-079
PL8	Lamp with wire 6V, 30mA	AEL-079

FUSES

Symbol	Description	Part No.
FU1	Fuse 2A (Secondary)	AEK-017
FU2	Fuse 800mA (Secondary)	AEK-031
FU3	Fuse 800mA (Secondary)	AEK-031
FU4	Fuse 500mA (Primary)	AEK-401

CAPACITOR

Symbol	Description	Part No.
C2	Ceramic 0.04 50V	CKDYF 403Z 50

NOTE:

The indicated semiconductors are representative ones only. Other alternative semiconductors may be used and are listed in the parts list.

A

B

C

D

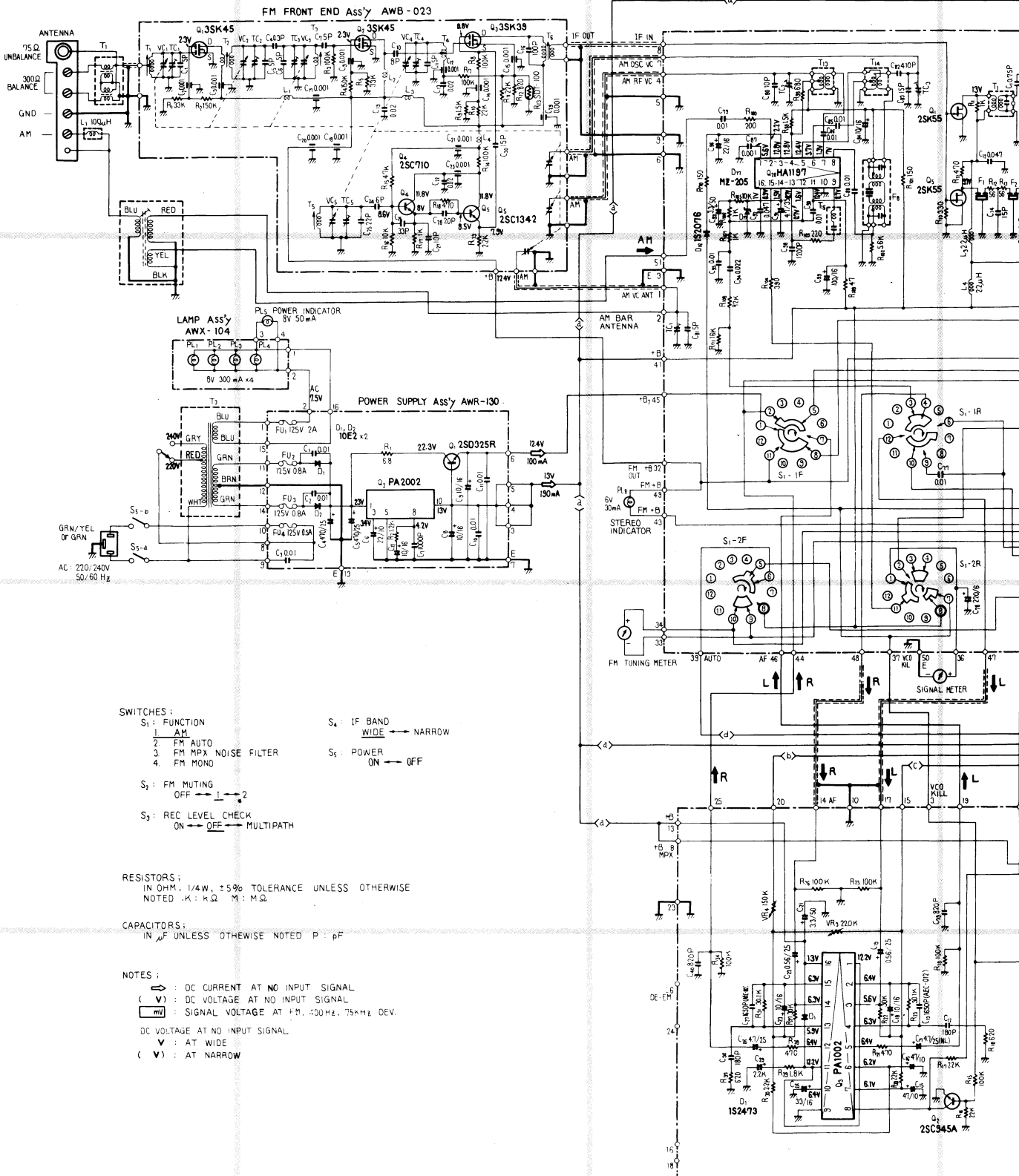

- SWITCHES:**
- S₁ : FUNCTION
 - 1 AM
 - 2 FM AUTO
 - 3 FM MPX NOISE FILTER
 - 4 FM MONO
 - S₂ : FM MUTING
 - OFF 1 → 2
 - S₃ : REC LEVEL CHECK
 - ON → OFF → MULTIPATH
 - S₄ : IF BAND
 - WIDE → NARROW
 - S₅ : POWER
 - ON → OFF

RESISTORS:
IN OHM, 1/4W, ±5% TOLERANCE UNLESS OTHERWISE NOTED. K: KΩ M: MΩ

CAPACITORS:
IN μF UNLESS OTHERWISE NOTED. P: pF

- NOTES:**
- ↔ : DC CURRENT AT NO INPUT SIGNAL
 - (V) : DC VOLTAGE AT NO INPUT SIGNAL
 - (mv) : SIGNAL VOLTAGE AT FM: 400Hz, 75kHz DEV.
 - DC VOLTAGE AT NO INPUT SIGNAL
 - ∇ : AT WIDE
 - (∇) : AT NARROW

3.2 MPX AF ASSEMBLY (AWD-008)

A

B

C

D

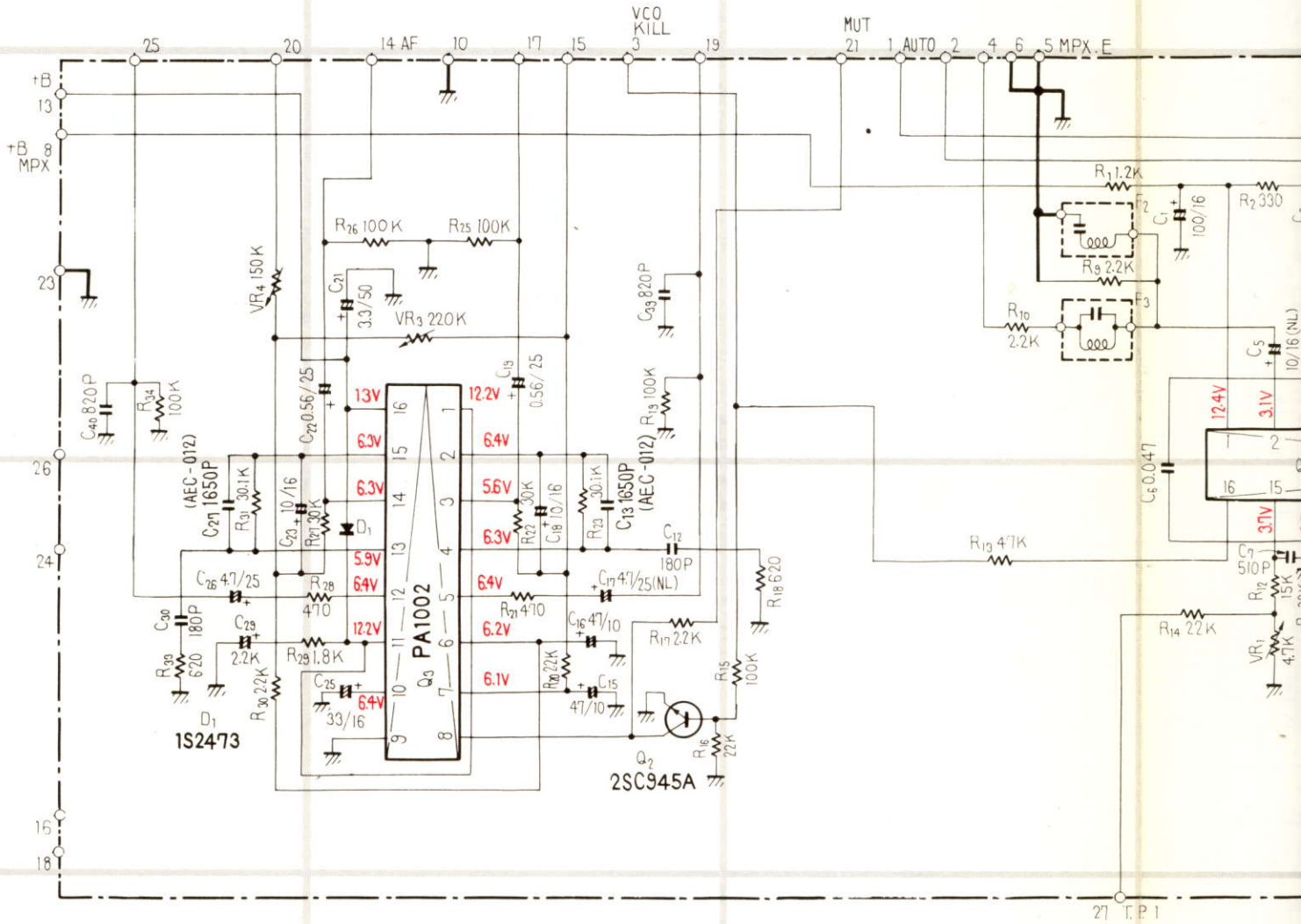

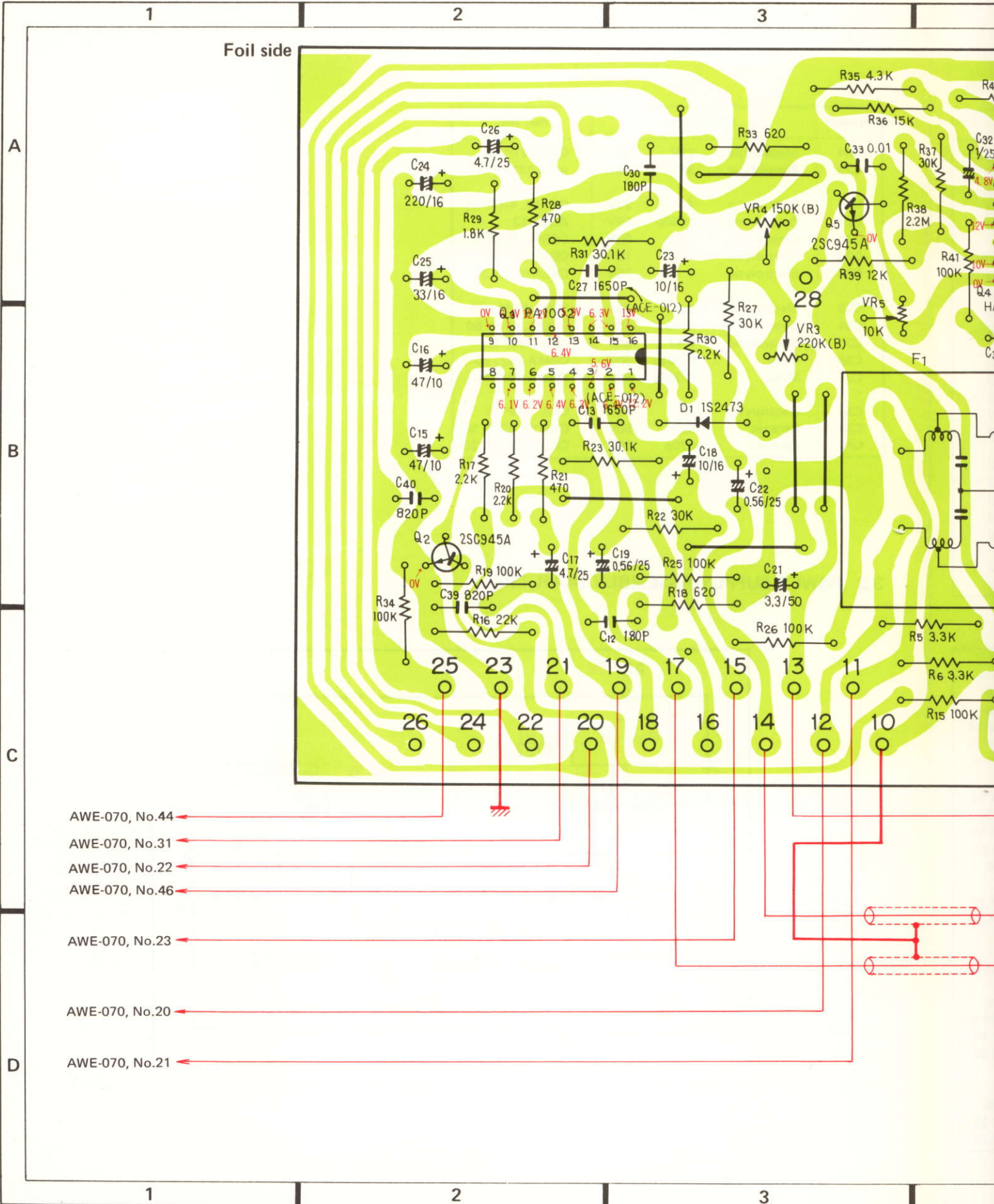

Parts List of MPX AF Assembly (AWD-008)

SEMICONDUCTORS

Symbol	Description	Part No.
Q1	IC	PA1001
Q2	Transistor	2SC945A-Q or R (2SC1647-Q or R)
Q3	IC	PA1002
Q4	IC	HA1452
Q5	Transistor	2SC945A-Q or R (2SC1647-Q or R)
D1	Diode	1S2473 (1S2076)

FILTERS

Symbol	Description	Part No.
F1	Low pass filter	ATF-028
F2	Anti-birdy filter	ATF-024
F3	Anti-birdy filter	ATF-023

RESISTORS

Symbol	Description	Part No.
VR1	Semi-fixed (4.7k)	ACP-018
VR2	Semi-fixed (22k)	ACP-056
VR3	Semi-fixed (220k)	ACP-016
VR4	Semi-fixed (150k)	ACP-057
VR5	Semi-fixed (10k)	C92-049
R1	Carbon film 12	RD¼PS 120J
R2	Carbon film 330	RD¼PS 331J
R3	Metal film 3.3k ½W	RN½SQ 3301F
R4	Metal film 3.3k ½W	RN½SQ 3301F
R5	Carbon film 3.3k	RD¼PS 332J
R6	Carbon film 3.3k	RD¼PS 332J
R7	Carbon film 12k	RD¼PS 123J
R8	Carbon film 180	RD¼PS 181J
R9	Carbon film 2.2k	RD¼PS 222J
R10	Carbon film 2.2k	RD¼PS 222J
R11	Carbon film 2.2k	RD¼PS 222J
R12	Carbon film 15k	RD¼PS 153J
R13	Carbon film 47k	RD¼PS 473J
R14	Carbon film 22k	RD¼PS 223J
R15	Carbon film 100k	RD¼PS 104J
R16	Carbon film 22k	RD¼PS 223J
R17	Carbon film 2.2k	RD¼PS 222J
R18	Carbon film 620	RD¼PS 621J
R19	Carbon film 100k	RD¼PS 104J
R20	Carbon film 2.2k	RD¼PS 222J
R21	Carbon film 470	RD¼PS 471J
R22	Carbon film 30k	RD¼PS 303J
R23	Metal film 30.1k ½W	RN½SQ 3012F
R24	Carbon film 24k	RD¼PS 243J
R25	Carbon film 100k	RD¼PS 104J

Symbol	Description	Part No.
R26	Carbon film 100k	RD¼PS 104J
R27	Carbon film 30k	RD¼PS 303J
R28	Carbon film 470	RD¼PS 471J
R29	Carbon film 1.8k	RD¼PS 182J
R30	Carbon film 2.2k	RD¼PS 222J
R31	Metal film 30.1k ½W	RN½SQ 3012F
R33	Carbon film 620	RD¼PS 621J
R34	Carbon film 100k	RD¼PS 104J
R35	Carbon film 4.3k	RD¼PS 432J
R36	Carbon film 15k	RD¼PS 153J
R37	Carbon film 30k	RD¼PS 303J
R38	Carbon film 2.2M	RD¼PS 225J
R39	Carbon film 12k	RD¼PS 123J
R40	Carbon film 100	RD¼PS 101J
R41	Carbon film 100k	RD¼PS 104J
R42	Carbon film 75k	RD¼PS 753J
R43	Carbon film 91k	RD¼PS 913J
R44	Carbon film 33k	RD¼PS 333J
R45	Carbon film 91k	RD¼PS 913J
R46	Carbon film 100k	RD¼PS 104J
R47	Carbon film 1.5k	RD¼PS 152J
R48	Carbon film 1.5k	RD¼PS 152J

CAPACITORS

Symbol	Description	Part No.
C1	Electrolytic 100 16V	CEA 101P 16
C2	Electrolytic 470 16V	CEA 471P 16
C3	Electrolytic 10 16V	CEANL 100P 16
C4	Electrolytic 10 16V	CEANL 100P 16
C5	Electrolytic 10 16V	CEANL 100P 16
C6	Mylar 0.047 50V	CQMA 473K 50
C7	Polystyrene 510p 50V	CQSH 511J 50
C8	Electrolytic 0.33 35V	CSZA R33M 35
C9	Electrolytic 1 25V	CSZA 010M 25
C10	Electrolytic 1 50V	CEA 010P 50
C11	Electrolytic 3.3 10V	CSZA 3R3M 10
C12	Ceramic 180p 50V	CCDSL 181K 50
C13	Polystyrene 1650p 50V	ACE-012
C14		
C15	Electrolytic 47 10V	CEA 470P 10
C16	Electrolytic 47 10V	CEA 470P 10
C17	Electrolytic 4.7 25V	CEANL 4R7P 25
C18	Electrolytic 10 16V	CSZA 100M 16
C19	Electrolytic 0.56 35V	CSZA R56K 35
C20		
C21	Electrolytic 3.3 50V	CEA 3R3P 50
C22	Electrolytic 0.56 35V	CSZA R56K 35
C23	Electrolytic 10 16V	CSZA 100M 16

Symbol	Description	Part No.
C24	Electrolytic 220 16V	CEA 221P 16
C25	Electrolytic 33 16V	ACH-321
C26	Electrolytic 4.7 25V	CEANL 4R7P 25
C27	Polystyrene 1650p 50V	ACE-012
C30	Ceramic 180p 50V	CCDSL 181K 50
C31	Electrolytic 100 16V	CEA 101P 16
C32	Electrolytic 1 25V	CSZA 010M 25
C33	Electrolytic 0.1 35V	CSZA 0R1M 35
C34	Ceramic 470p 50V	CCDSL 471K 50
C35	Electrolytic 0.47 50V	CEA R47P 50
C36	Mylar 0.0039 50V	CQMA 392J 50
C37	Mylar 0.0039 50V	CQMA 392J 50
C38	Electrolytic 10 16V	CEA 100P 16
C39	Ceramic 820p 50V	CKDYB 821K 50
C40	Ceramic 820p 50V	CKDYB 821K 50

3.3 POWER SUPPLY ASSEMBLY (AWR-130)

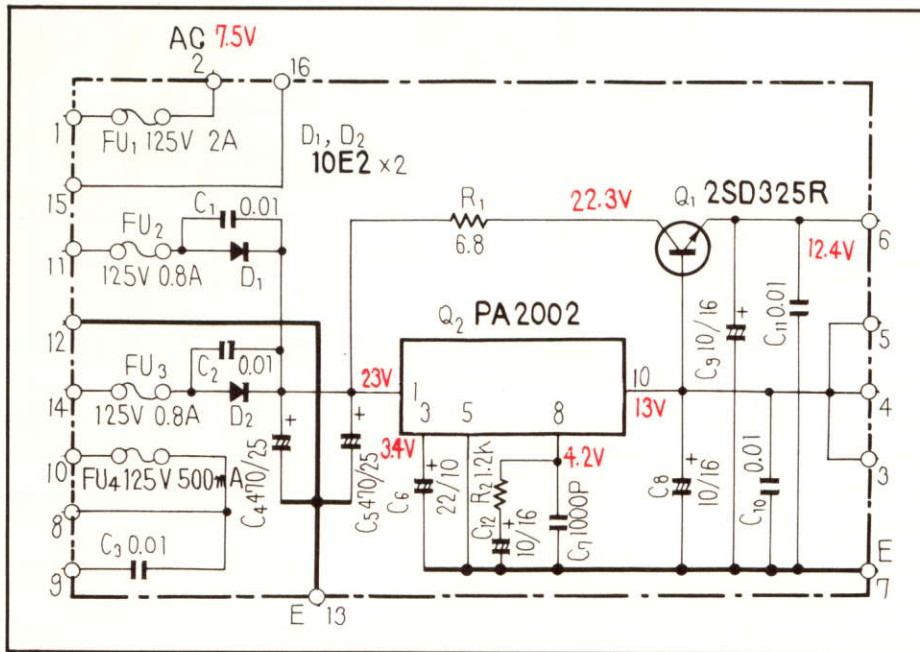

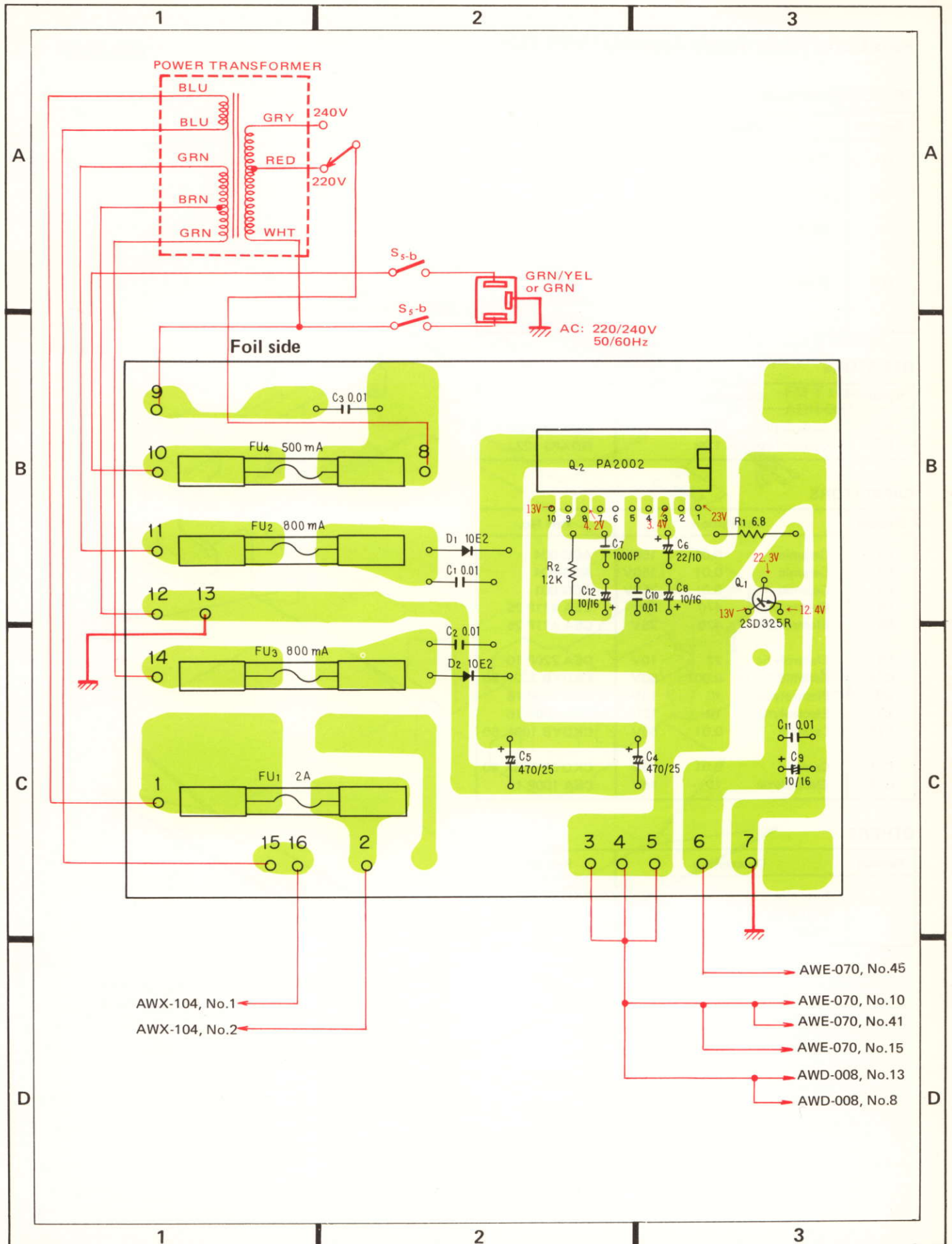

Parts List of Power Supply Assembly (AWR-130)

SEMICONDUCTORS

Symbol	Description	Part No.
Q1	Transistor	2SD325R-E or D (2SD234-O or R)
Q2	IC	PA2002
D1	Diode	10E2 (S1B01-02) (1S1886)
D2	Diode	10E2 (S1B01-02) (1S1886)

RESISTORS

Symbol	Description	Part No.
R1	Carbon film 6.8	RD¼PS 6R8J
R2	Carbon film 1.2k	RD¼PS 122J

CAPACITORS

Symbol	Description	Part No.
C1	Ceramic 0.01 150V	ACG-004
C2	Ceramic 0.01 150V	ACG-004
C3	Ceramic 0.01 250V	ACG-001
C4	Electrolytic 470 25V	CEA 471P 25
C5	Electrolytic 470 25V	CEA 471P 25
C6	Electrolytic 22 10V	CEA 220P 10
C7	Ceramic 0.001 50V	CKDYB 102K 50
C8	Electrolytic 10 16V	CEA 100P 16
C9	Electrolytic 10 16V	CEA 100P 16
C10	Ceramic 0.01 50V	CKDYB 103K 50
C11	Ceramic 0.01 50V	CKDYB 103K 50
C12	Electrolytic 10 16V	CEA 100P 16

OTHERS

Symbol	Description	Part No.
	Fuse clip	AKR-010
	Heat sink	ANH-117
	Cover	AEC-279

3.4 PACKING

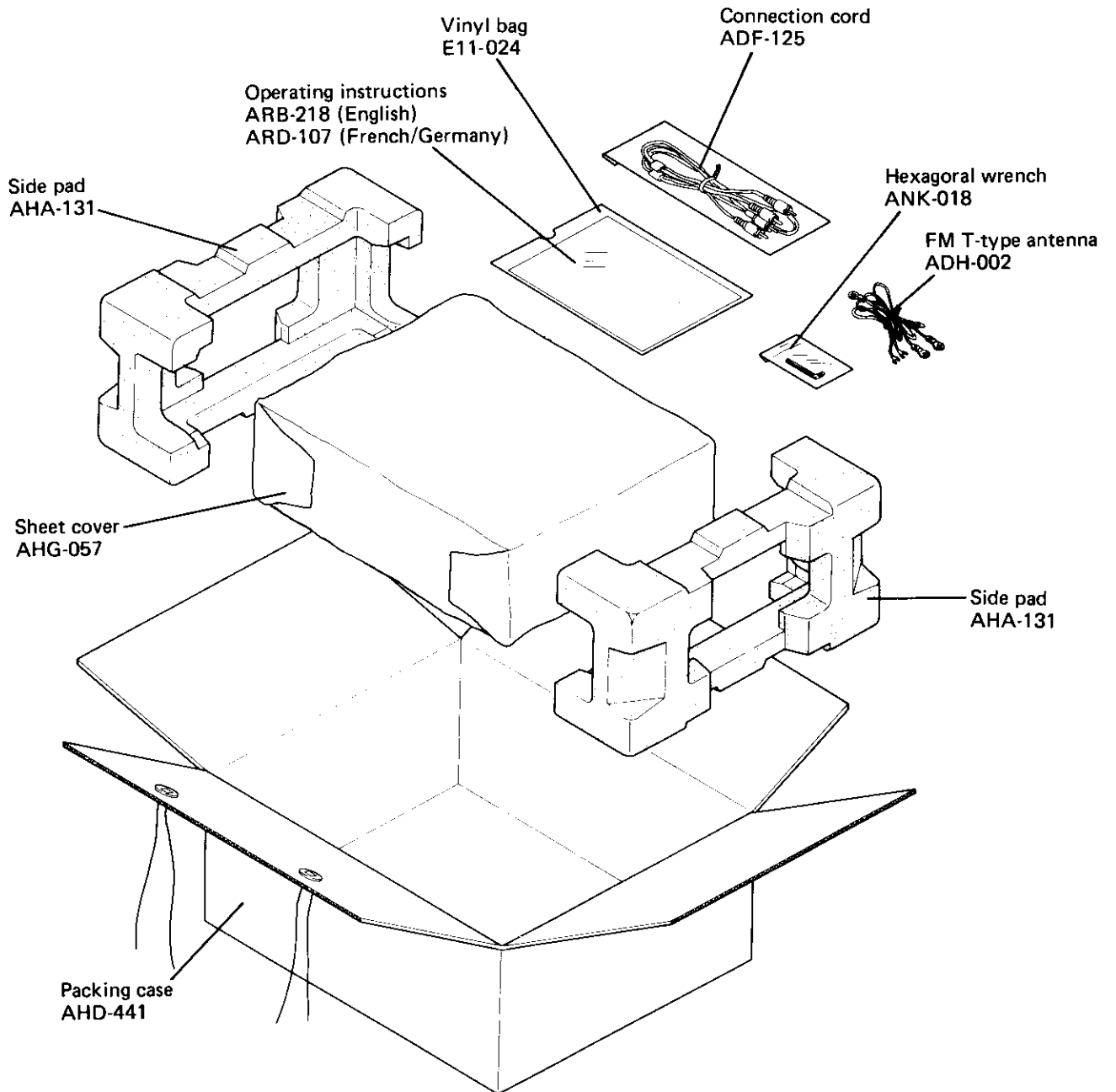

4. S TYPE

4.1 SCHEMATIC DIAGRAM AND MISCELLANEOUS PARTS LIST

Miscellaneous Parts List

NOTE:

- Capacitors: in μF unless otherwise noted p:pF
- Resistors: in Ω , $\frac{1}{4}W$ unless otherwise noted k:k Ω , M:M Ω

SWITCHES

Symbol	Description	Part No.
S5	Lever switch (POWER)	ASK-128
S7	Plug in selector (Line voltage selector)	AKR-031

TRANSFORMERS AND COIL

Symbol	Description	Part No.
T1	Ferrite balun	T22-025
T2	Bar antenna	ATB-507
T3	Power transformer	ATT-349
L1	RF choke coil	T24-030

LAMPS

Symbol	Description	Part No.
PL1	Lamp (Wedge type) 8V, 300mA	AEL-029
PL2	Lamp (Wedge type) 8V, 300mA	AEL-029
PL3	Lamp (Wedge type) 8V, 300mA	AEL-029
PL4	Lamp (Wedge type) 8V, 300mA	AEL-029
PL5	Lamp with wire 8V, 50mA	AEL-072
PL6	Lamp with wire 6V, 30mA	AEL-080
PL7	Lamp with wire 6V, 30mA	AEL-079
PL8	Lamp with wire 6V, 30mA	AEL-079

FUSE

Symbol	Description	Part No.
FU1	Fuse 500mA (Primary)	AEK-107

CAPACITORS

Symbol	Description	Part No.
C1	Ceramic 0.01 250V	ACG-001
C2	Ceramic 0.04 50V	CKDYF 403Z 50

NOTE:

The indicated semiconductors are representative ones only. Other alternative semiconductors may be used and are listed in the parts list.

A

B

C

D

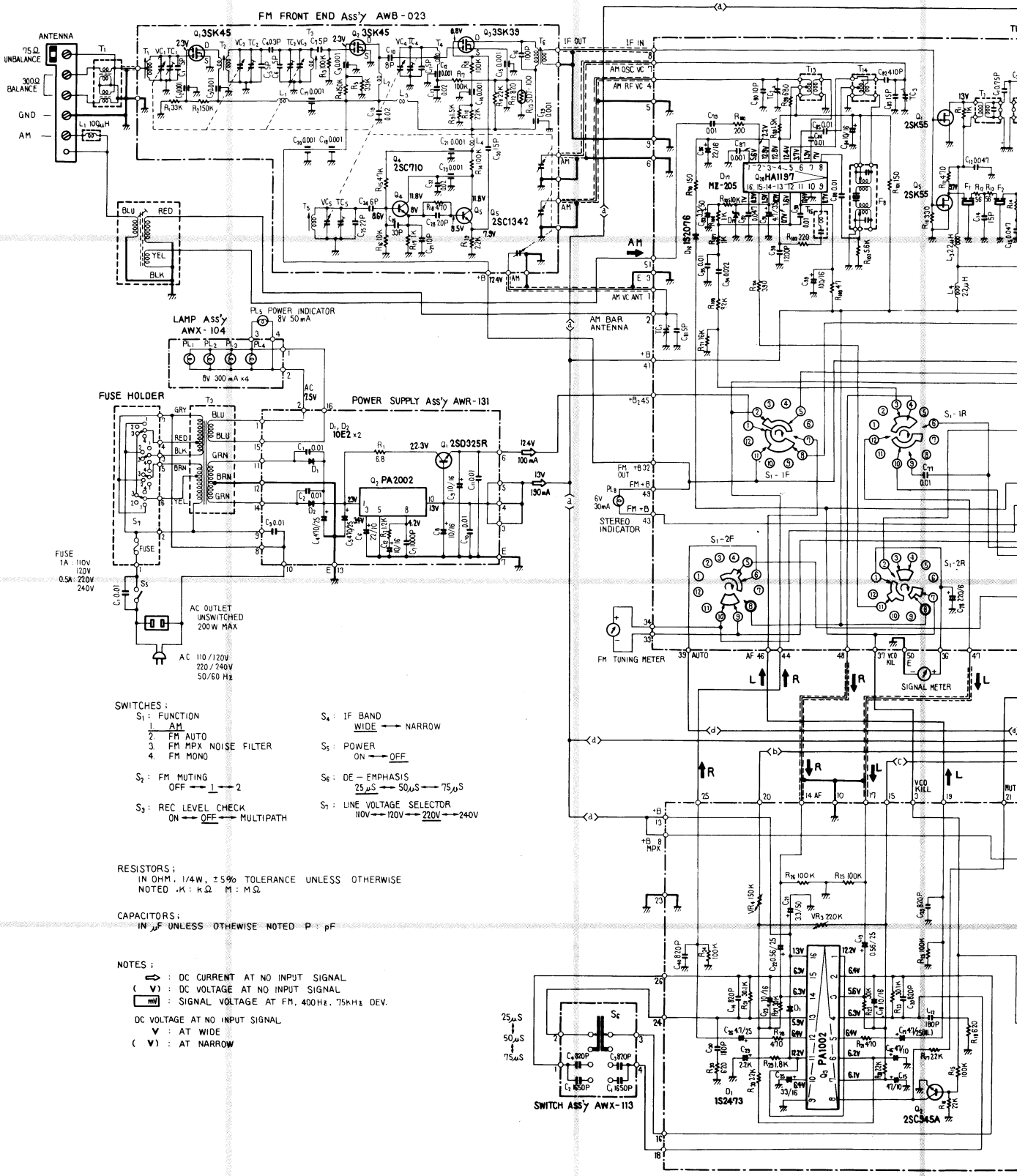

- SWITCHES :**
- S₁ : FUNCTION
1 AM
2 FM AUTO
3 FM MPX NOISE FILTER
4 FM MONO
 - S₂ : FM MUTING
OFF → 1 → 2
 - S₃ : REC LEVEL CHECK
ON → OFF → MULTIPATH
 - S₄ : IF BAND WIDE → NARROW
 - S₅ : POWER ON → OFF
 - S₆ : DE - EMPHASIS
25 μS → 50 μS → 75 μS
 - S₇ : LINE VOLTAGE SELECTOR
110V → 120V → 220V → 240V

RESISTORS :
IN OHM. 1/4W. ± 5% TOLERANCE UNLESS OTHERWISE NOTED .K : kΩ M : MΩ

CAPACITORS :
IN μF UNLESS OTHERWISE NOTED P : pF

- NOTES :**
- ⊖ : DC CURRENT AT NO INPUT SIGNAL
 - (V) : DC VOLTAGE AT NO INPUT SIGNAL
 - (m) : SIGNAL VOLTAGE AT FM, 400Hz, 75kHz DEV.
 - DC VOLTAGE AT NO INPUT SIGNAL
 - (V) : AT WIDE
 - (V) : AT NARROW

1

2

3

4

5

6

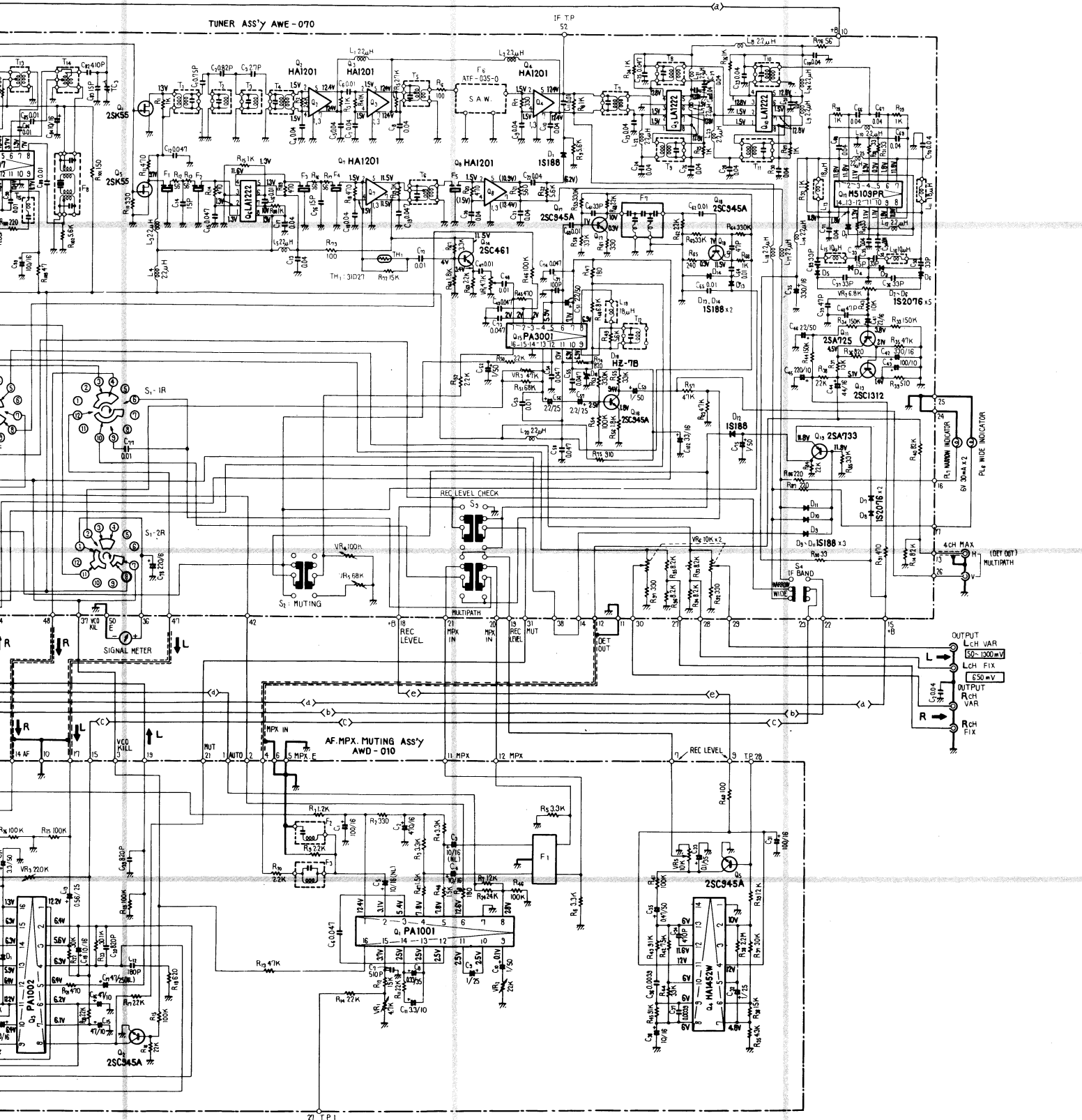

A

B

C

D

4

5

6

4.2 MPX AF ASSEMBLY (AWD-010)

A

B

C

D

1

2

3

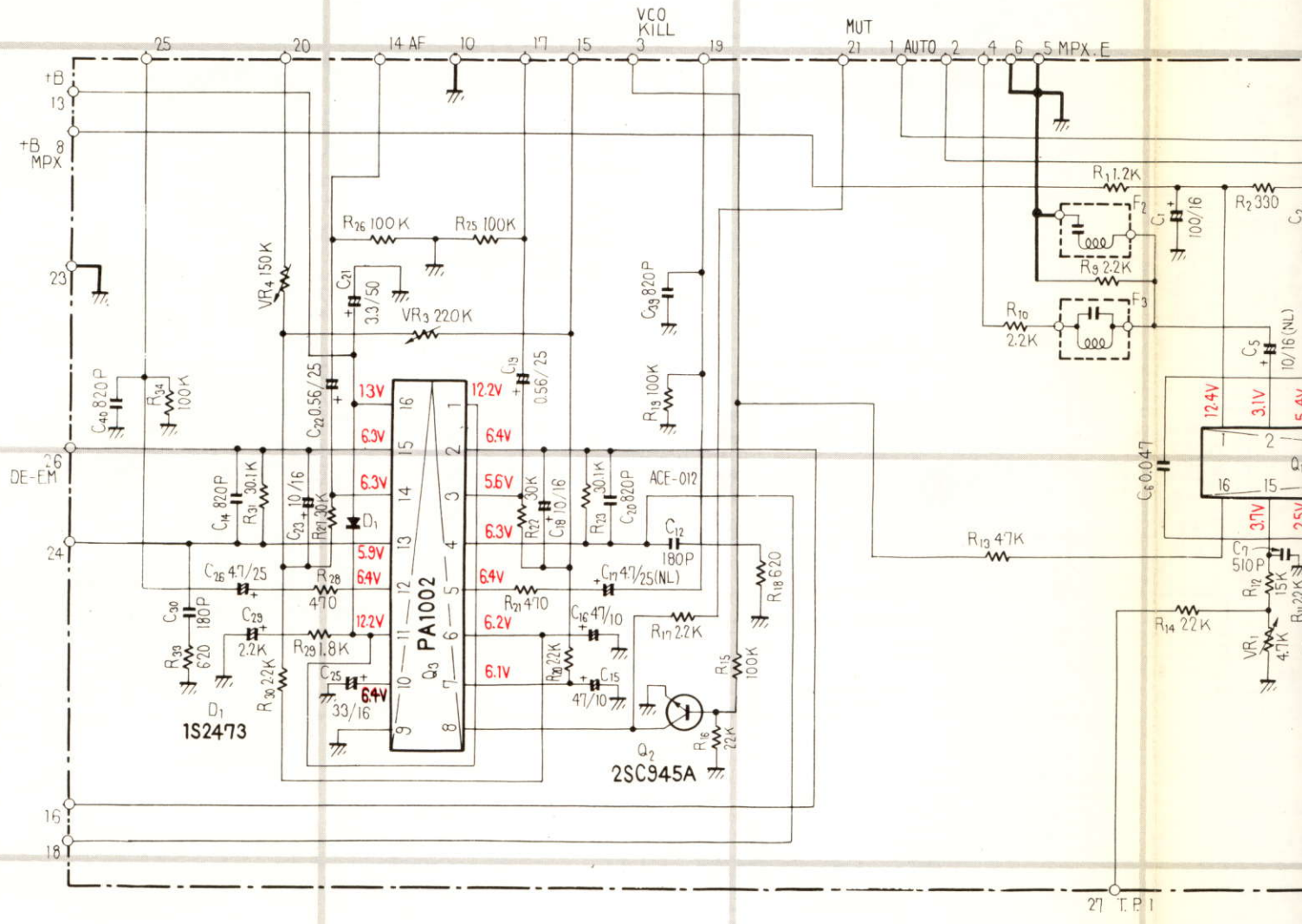

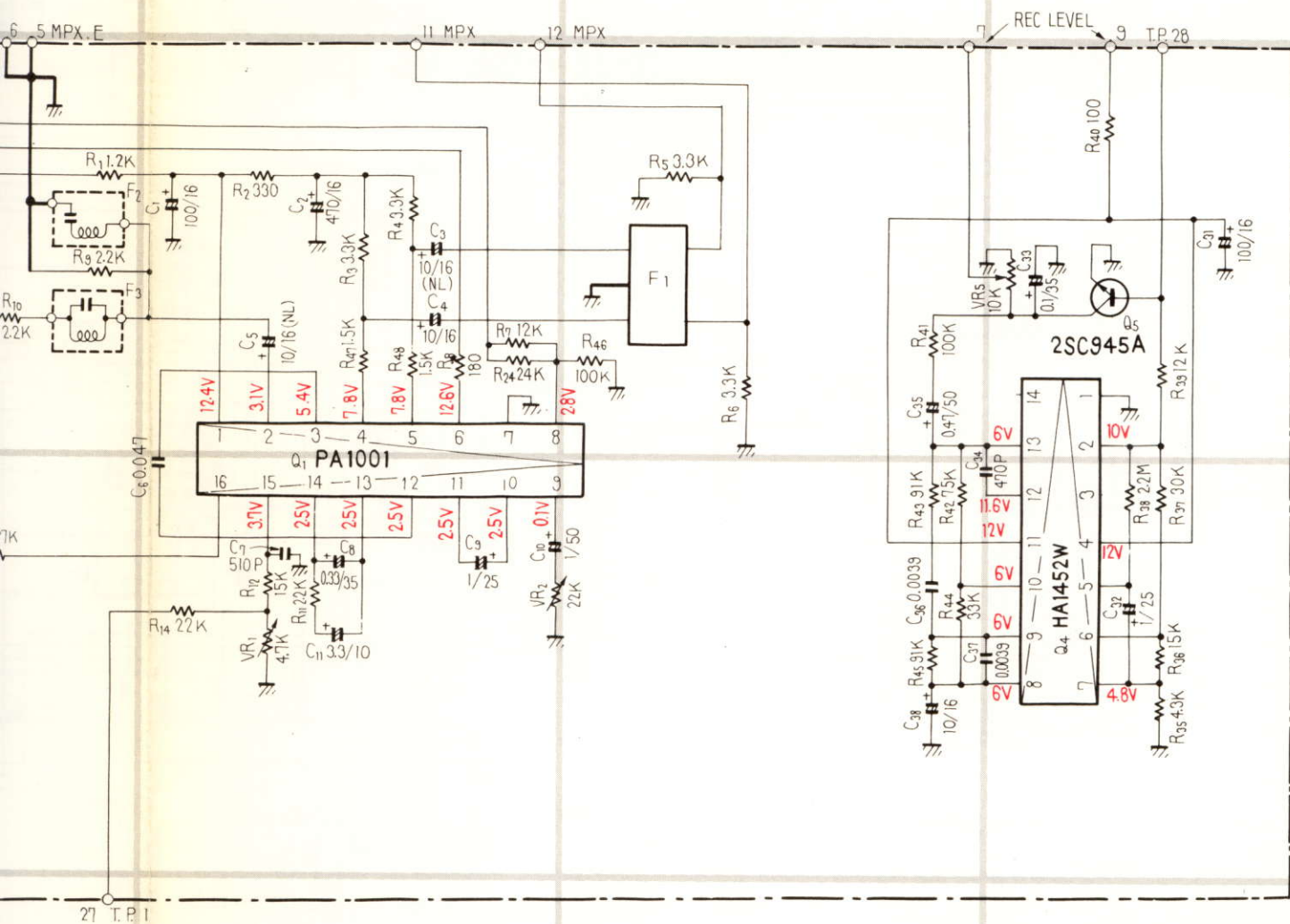

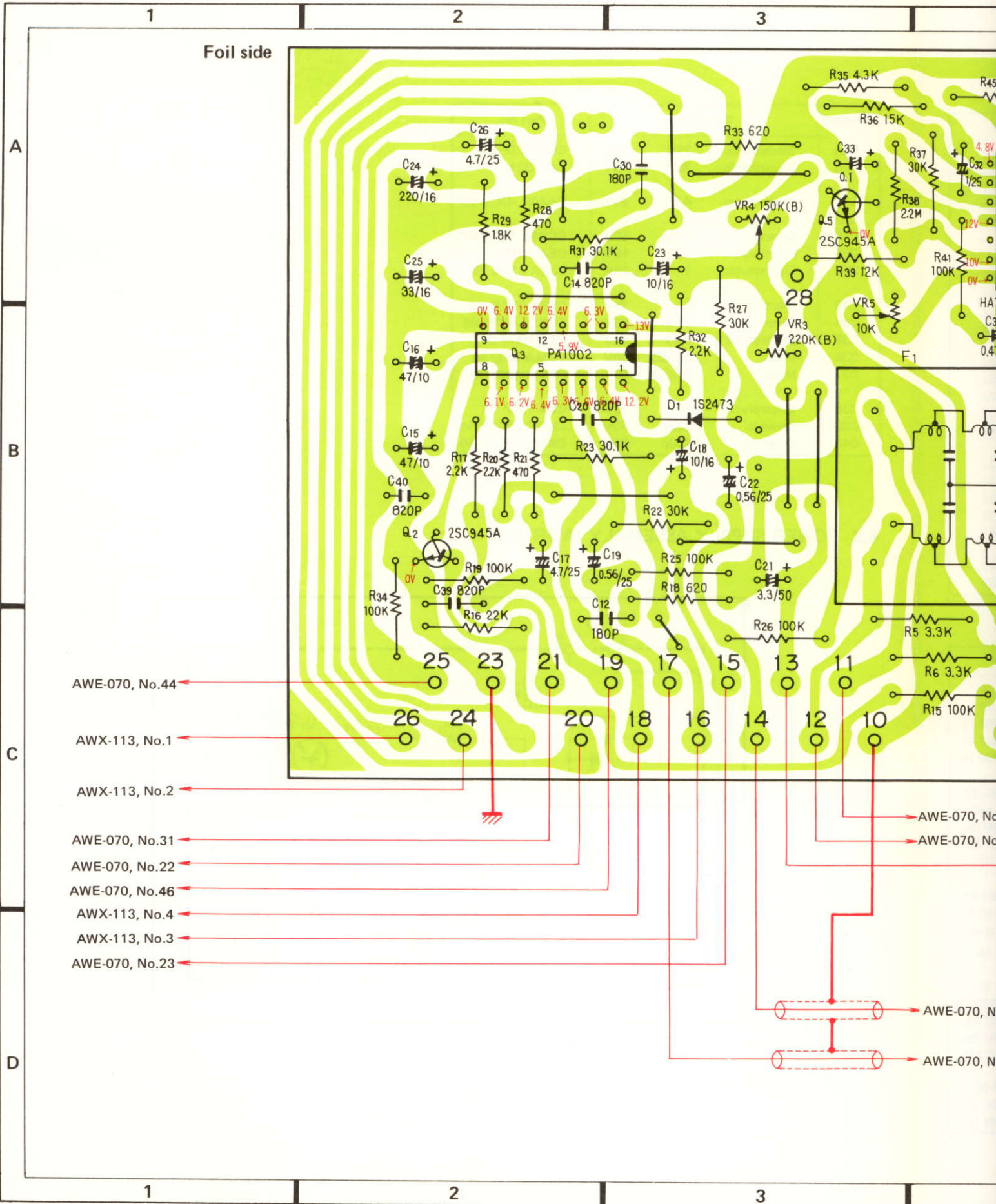

Foil side

AWE-070, No.44

AWX-113, No.1

AWX-113, No.2

AWE-070, No.31

AWE-070, No.22

AWE-070, No.46

AWX-113, No.4

AWX-113, No.3

AWE-070, No.23

AWE-070, No. N

AWE-070, No. N

AWE-070, No. N

AWE-070, No. N

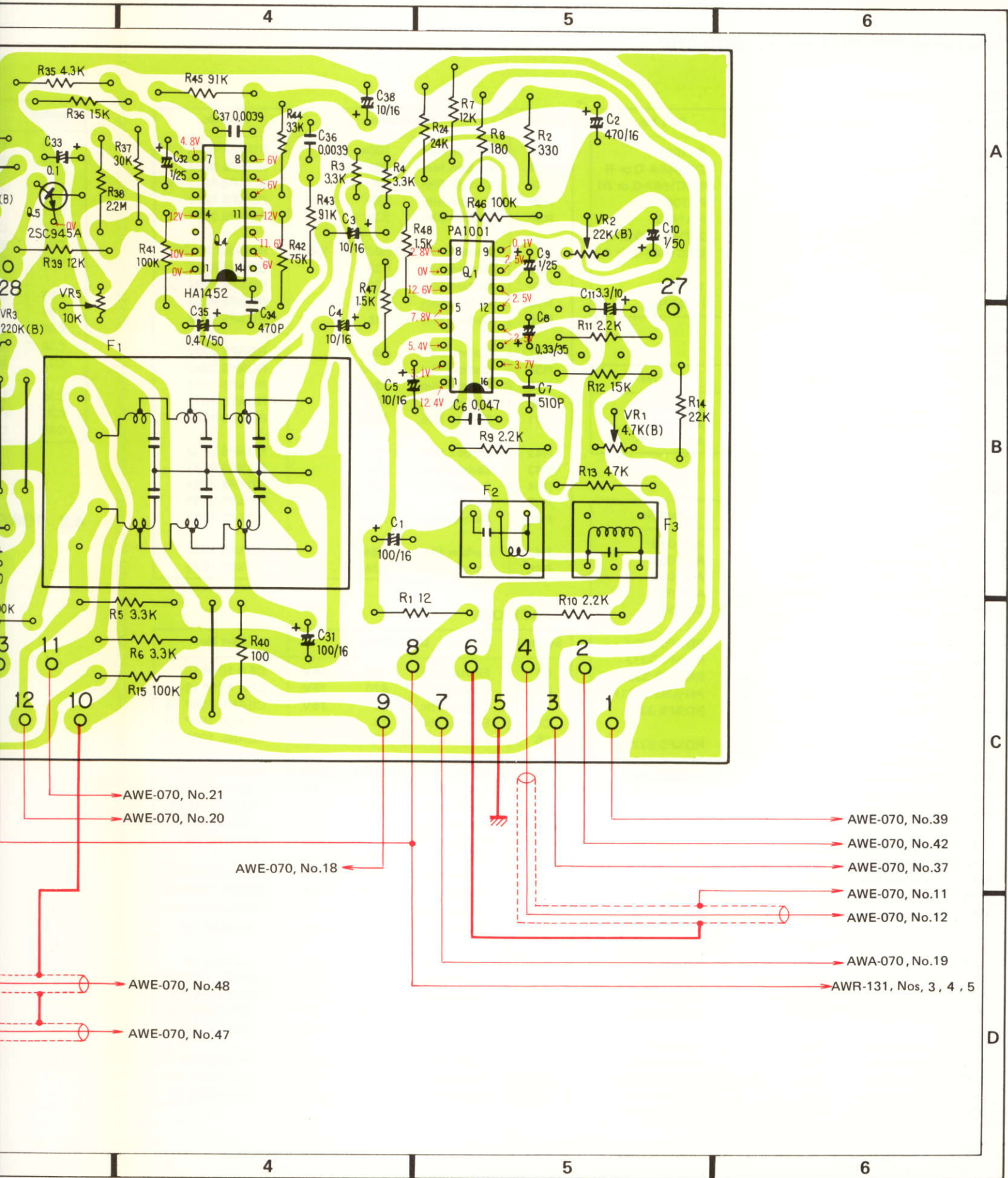

A

B

C

D

4

5

6

4

5

6

Parts List of MPX AF Assembly (AWD-010)

SEMICONDUCTORS

Symbol	Description	Part No.
Q1	IC	PA1001
Q2	Transistor	2SC945A-Q or R (2SC1647-Q or R)
Q3	IC	PA1002
Q4	IC	HA1452
Q5	Transistor	2SC945A-Q or R (2SC1647-Q or R)
D1	Diode	1S2473 (1S2076)

FILTERS

Symbol	Description	Part No.
F1	Low pass filter	ATF-028
F2	Anti-birdy filter	ATF-024
F3	Anti-birdy filter	ATF-023

RESISTORS

Symbol	Description	Part No.
VR1	Semi-fixed (4.7k)	ACP-018
VR2	Semi-fixed (22k)	ACP-056
VR3	Semi-fixed (220k)	ACP-016
VR4	Semi-fixed (150k)	ACP-057
VR5	Semi-fixed (10k)	C92-049
R1	Carbon film 12	RD¼PS 120J
R2	Carbon film 330	RD¼PS 331J
R3	Metal film 3.3k ½W	RN½SQ 3301F
R4	Metal film 3.3k ½W	RN½SQ 3301F
R5	Carbon film 3.3k	RD¼PS 332J
R6	Carbon film 3.3k	RD¼PS 332J
R7	Carbon film 12k	RD¼PS 123J
R8	Carbon film 180	RD¼PS 181J
R9	Carbon film 2.2k	RD¼PS 222J
R10	Carbon film 2.2k	RD¼PS 222J
R11	Carbon film 2.2k	RD¼PS 222J
R12	Carbon film 15k	RD¼PS 153J
R13	Carbon film 47k	RD¼PS 473J
R14	Carbon film 22k	RD¼PS 223J
R15	Carbon film 100k	RD¼PS 104J
R16	Carbon film 22k	RD¼PS 223J
R17	Carbon film 2.2k	RD¼PS 222J
R18	Carbon film 620	RD¼PS 621J
R19	Carbon film 100k	RD¼PS 104J
R20	Carbon film 2.2k	RD¼PS 222J
R21	Carbon film 470	RD¼PS 471J
R22	Carbon film 30k	RD¼PS 303J
R23	Metal film 30.1k ½W	RN½SQ 3012F
R24	Carbon film 24k	RD¼PS 243J
R25	Carbon film 100k	RD¼PS 104J

Symbol	Description	Part No.
R26	Carbon film 100k	RD¼PS 104J
R27	Carbon film 30k	RD¼PS 303J
R28	Carbon film 470	RD¼PS 471J
R29	Carbon film 1.8k	RD¼PS 182J
R30	Carbon film 2.2k	RD¼PS 222J
R31	Metal film 30.1k ½W	RN½SQ 3012F
R33	Carbon film 620	RD¼PS 621J
R34	Carbon film 100k	RD¼PS 104J
R35	Carbon film 4.3k	RD¼PS 432J
R36	Carbon film 15k	RD¼PS 153J
R37	Carbon film 30k	RD¼PS 303J
R38	Carbon film 2.2M	RD¼PS 225J
R39	Carbon film 12k	RD¼PS 123J
R40	Carbon film 100	RD¼PS 101J
R41	Carbon film 100k	RD¼PS 104J
R42	Carbon film 75k	RD¼PS 753J
R43	Carbon film 91k	RD¼PS 913J
R44	Carbon film 33k	RD¼PS 333J
R45	Carbon film 91k	RD¼PS 913J
R46	Carbon film 100k	RD¼PS 104J
R47	Carbon film 1.5k	RD¼PS 152J
R48	Carbon film 1.5k	RD¼PS 152J

CAPACITORS

Symbol	Description	Part No.
C1	Electrolytic 100 16V	CEA 101P 16
C2	Electrolytic 470 16V	CEA 471P 16
C3	Electrolytic 10 16V	CEANL 100P 16
C4	Electrolytic 10 16V	CEANL 100P 16
C5	Electrolytic 10 16V	CEANL 100P 16
C6	Mylar 0.047 50V	CQMA 473K 50
C7	Polystyrene 510p 50V	CQSH 511J 50
C8	Electrolytic 0.33 35V	CSZA R33M 35
C9	Electrolytic 1 25V	CSZA 010M 25
C10	Electrolytic 1 50V	CEA 010P 50
C11	Electrolytic 3.3 10V	CSZA 3R3M 10
C12	Ceramic 180p 50V	CCDSL 181K 50
C14	Polystyrene 820p 50V	CQSA 821G 50
C15	Electrolytic 47 10V	CEA 470P 10
C16	Electrolytic 47 10V	CEA 470P 10
C17	Electrolytic 4.7 25V	CEANL 4R7P 25
C18	Electrolytic 10 16V	CSZA 100M 16
C19	Electrolytic 0.56 35V	CSZA R56K 35
C20	Polystyrene 820p 50V	CQSA 821G 50
C21	Electrolytic 3.3 50V	CEA 3R3P 50
C22	Electrolytic 0.56 35V	CSZA R56K 35
C23	Electrolytic 10 16V	CSZA 100M 16

Symbol	Description				Part No.
C24	Electrolytic	220	16V	CEA 221P 16	
C25	Electrolytic	33	16V	ACH-321	
C26	Electrolytic	4.7	25V	CEANL 4R7P 25	
C27					
C30	Ceramic	180p	50V	CCDSL 181K 50	
C31	Electrolytic	100	16V	CEA 101P 16	
C32	Electrolytic	1	25V	CSZA 010M 25	
C33	Electrolytic	0.1	35V	CSZA 0R1M 35	
C34	Ceramic	470p	50V	CCDSL 471K 50	
C35	Electrolytic	0.47	50V	CEA R47P 50	
C36	Mylar	0.0039	50V	CQMA 392J 50	
C37	Mylar	0.0039	50V	CQMA 392J 50	
C38	Electrolytic	10	16V	CEA 100P 16	
C39	Ceramic	820p	50V	CKDYB 821K 50	
C40	Ceramic	820p	50V	CKDYB 821K 50	

4.3 POWER SUPPLY ASSEMBLY (AWR-131)

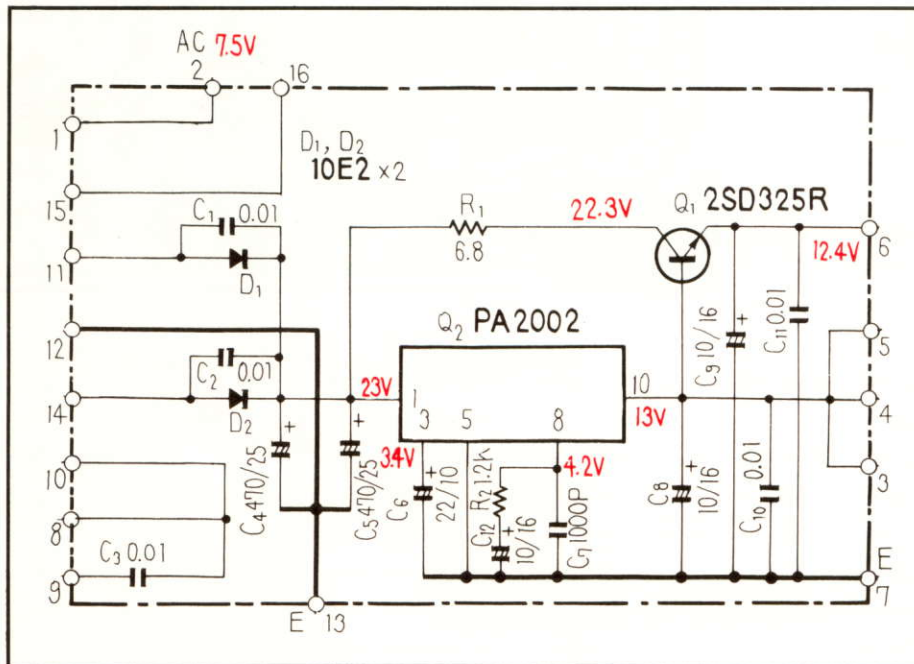

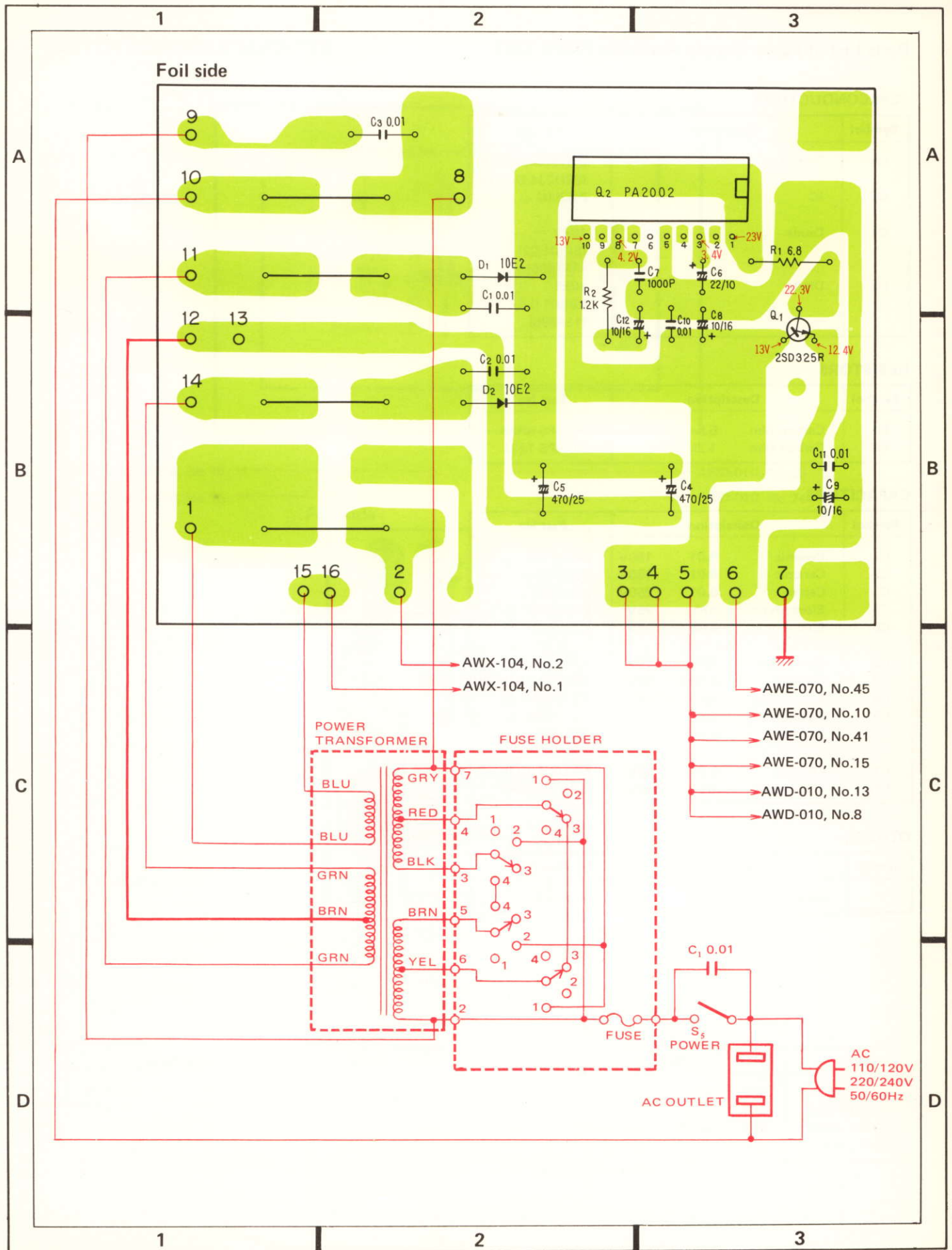

Parts List of Power Supply Assembly (AWR-131)

SEMICONDUCTORS

Symbol	Description	Part No.
Q1	Transistor	2SD325R-D or R (2SD234-O or R)
Q2	IC	PA2002
D1	Diode	10E2 (S1B01-02) (1S1886)
D2	Diode	10E2 (S1B01-02) (1S1886)

RESISTORS

Symbol	Description	Part No.
R1	Carbon film 6.8	RD¼PS 6R8J
R2	Carbon film 1.2k	RD¼PS 122J

CAPACITORS

Symbol	Description	Part No.
C1	Ceramic 0.01 150V	ACG-004
C2	Ceramic 0.01 150V	ACG-004
C3	Ceramic 0.01 250V	ACG-001
C4	Electrolytic 470 25V	CEA 471P 25
C5	Electrolytic 470 25V	CEA 471P 25
C6	Electrolytic 22 10V	CEA 220P 10
C7	Ceramic 0.001 50V	CKDYB 102K 50
C8	Electrolytic 10 16V	CEA 100P 16
C9	Electrolytic 10 16V	CEA 100P 16
C10	Ceramic 0.01 50V	CKDYB 103K 50
C11	Ceramic 0.01 50V	CKDYB 103K 50
C12	Electrolytic 10 16V	CEA 100P 16

OTHERS

Symbol	Description	Part No.
	Heat sink	ANH-117

4.4 SWITCH ASSEMBLY (AWX-113)

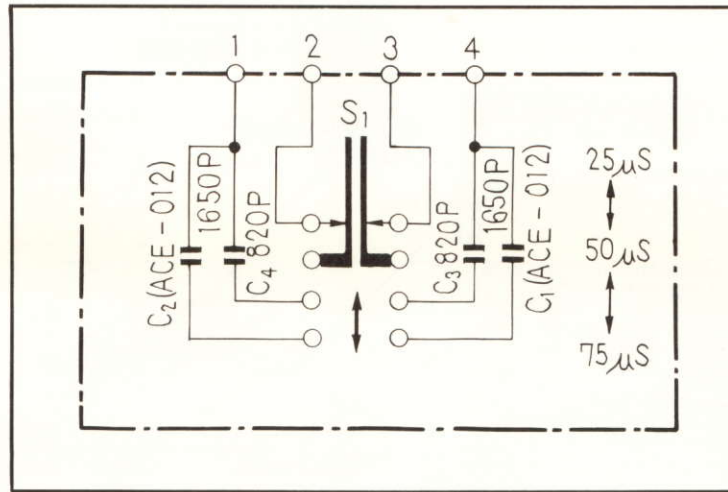

AWD-010, No.18 ←
 AWD-010, No.16 ←

AWD-010, No.26 →
 AWD-010, No.24 →

Foil side

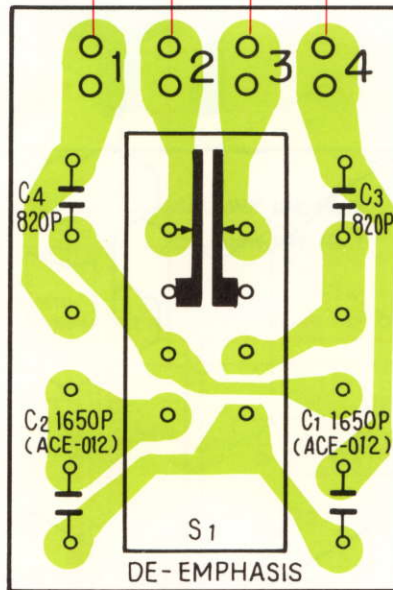

Parts List

SWITCH

Symbol	Description	Part No.
S1	Slide switch (DE-EMPHASIS)	ASH-017

CAPACITORS

Symbol	Description	Part No.
C1	Polystyrene 1650p 50V	ACE-012
C2	Polystyrene 1650p 50V	ACE-012
C3	Polystyrene 820p 50V	CQSA 821G 50
C4	Polystyrene 820p 50V	CQSA 821G 50

4.5 PACKING

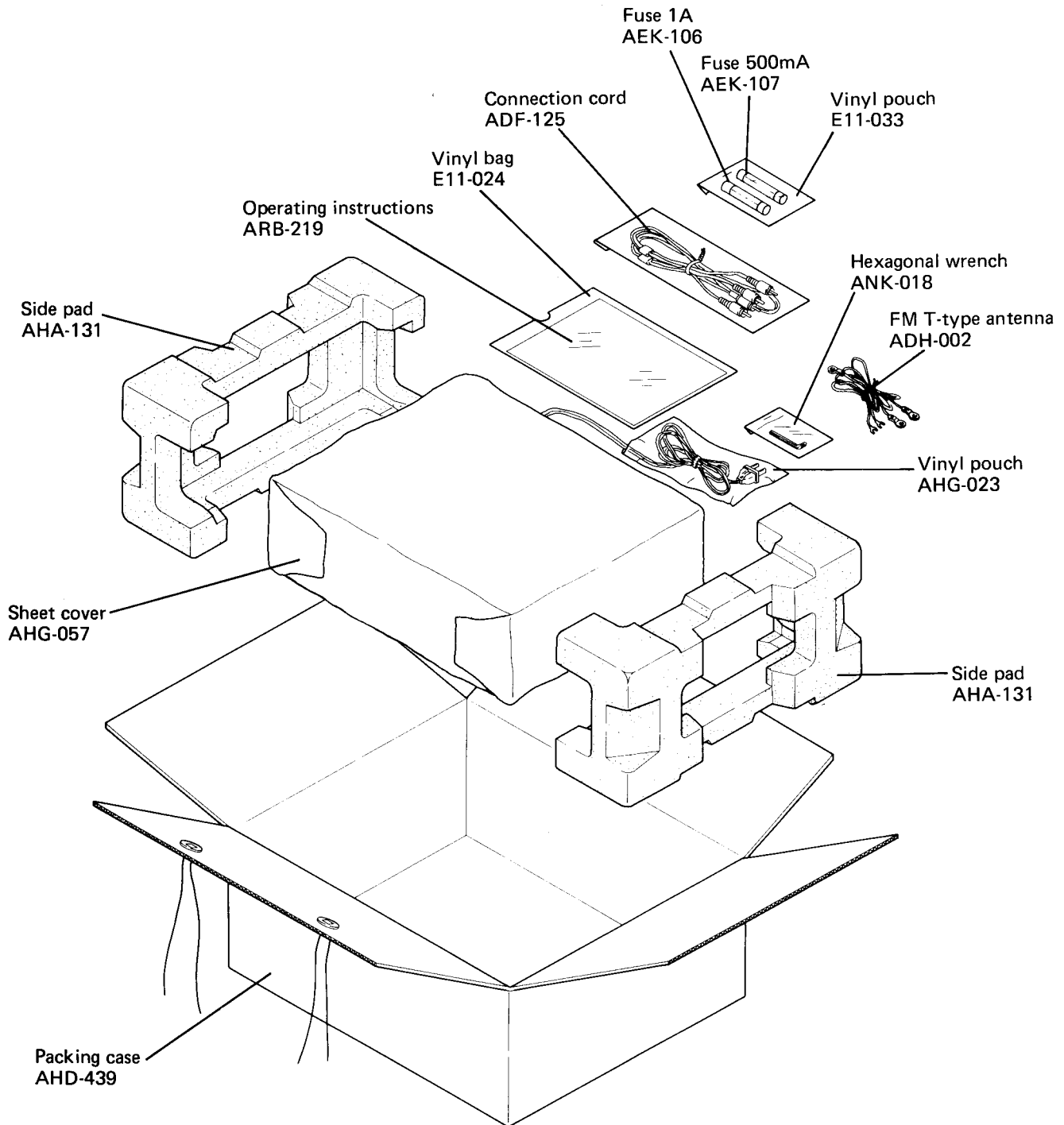

149

PIONEER ELECTRONIC CORPORATION

4-1, Meguro 1-Chome, Meguro-ku, Tokyo 153, Japan

U.S. PIONEER ELECTRONICS CORPORATION

75 Oxford Drive, Moonachie, New Jersey 07074, U.S.A.

PIONEER ELECTRONIC (EUROPE) N.V.

Luithagen-Haven 9, 2030 Antwerp, Belgium

PIONEER ELECTRONICS AUSTRALIA PTY. LTD.

178-184 Boundary Road, Braeside, Victoria 3195, Australia

<76K04Y5L01>

©NOV. 1976

Printed in Japan
<ART-203-0>