

REALISTIC®

Service Manual

31-1961

TM-1001
AM/FM STEREO TUNER
Catalog Number : 31-1961



CUSTOM MANUFACTURED FOR RADIO SHACK  A DIVISION OF TANDY CORPORATION

CONTENTS

	Page
1. SPECIFICATIONS	3 & 4
2. BLOCK DIAGRAM	5
3. DISASSEMBLY INSTRUCTIONS	6
4. DIAL STRINGING DIAGRAM	6
5. ALIGNMENT PROCEDURES	7 - 9
6. ALIGNMENT & CHECK POINTS	10
7. TROUBLESHOOTING	11 - 13
8. IC EQUIVALENT CIRCUIT	13
9. 0063 TUNER BOARD	14 & 15
10. SEMICONDUCTOR LEAD IDENTIFICATION	16
11. ELECTRICAL PARTS LIST	16 - 22
12. MISCELLANEOUS PARTS LIST	23
13. SCHEMATIC DIAGRAM	SEPARATE SHEET
14. EXPLODED VIEW	SEPARATE SHEET

SPECIFICATIONS

	NOMINAL	LIMIT	UNIT
FM SECTION			
1. TUNING COVERAGE	87.5-108.5	88-108	MHz
2. IHF USABLE SENSITIVITY	1.7	2.3	μ V
	8.8	13.5	dBf
3. IMAGE REJECTION RATIO (at 106 MHz)	78	70	dB
4. AFC HOLDING RANGE (with 1 mV input)			
WIDE	± 1000	± 800	kHz
NARROW	± 800	± 500	kHz
5. DIAL CALIBRATION ACCURACY			
90 MHz		± 250	kHz
98 MHz		± 350	kHz
106 MHz		± 250	kHz
6. IF BANDWIDTH (6 dB down)			
WIDE		± 150	kHz
NARROW		± 100	kHz
7. DISCRIMINATOR BANDWIDTH (peak-to-peak)	400	300	kHz
8. OUTPUT VOLTAGE (1 mV input) MONO 50 Kohm load	850	850 \pm 3dB	mV
9. SIGNAL-TO-NOISE RATIO (1mV input)	70	65	dB
10. FULL LIMITING (-3 dB)	1.2	1.8	μ V
11. CAPTURE RATIO 98 MHz (1 mV input)	1	2.5	dB
12. IHF SELECTIVITY			
WIDE	45	35	dB
NARROW	75	65	dB
13. OVERLOAD (at 98 MHz, 100 mV input)	0.2	0.5	%
14. IF REJECTION (at 90 MHz)	90	80	dB
15. DISTORTION (1 mV input, 400 Hz)			
WIDE	0.1	0.4	%
NARROW	0.2	0.6	%
16. MUTING THRESHOLD	8	4-16	μ V
17. AM REJECTION (AM 30%, FM 100% Mod.)			
at 98 MHz, 100 - 20,000 μ V input	45	40	dB
18. 50 dB QUIETING SENSITIVITY at 98 MHz	3	6	μ V
FM MPX SECTION			
1. STEREO SEPARATION			
100 Hz WIDE/NARROW	38/30	28/20	dB
(1 mV input)			
1 kHz WIDE/NARROW	40/35	32/26	dB
10 kHz WIDE/NARROW	32/28	25/20	dB
2. STEREO BEACON SENSITIVITY (Pilot 7 %)	7	4-16	μ V
3. DISTORTION 1 kHz (1 mV input)			
WIDE	0.2	0.6	%
NARROW	0.4	1.0	%
4. DE-EMPHASIS 75 μ Sec. (at 50-15,000 Hz)	± 1	± 2	dB
5. 38 kHz LEAKAGE (1 mV input)	-55	-45	dB
6. SCA REJECTION RATIO (1 mV input)	60	50	dB
7. OUTPUT VOLTAGE (1 mV input)			
at 1 kHz 50 Kohm Load	760	760 \pm 3dB	mV
AM SECTION			
1. TUNING COVERAGE	510-1660	520-1620	kHz
2. SENSITIVITY (for 20 dB S + N/N or 10 % THD)			
Radiated, at 600, 1000 and 1400 kHz	250	400	μ V/m
Terminal, at 600, 1000 and 1400 kHz	25	45	μ V
3. IMAGE REJECTION RATIO (at 1,400 kHz)	40	35	dB
4. OUTPUT VOLTAGE (5 mV/m input) 50 Kohm Load	320	320 \pm 3dB	mV
5. DIAL CALIBRATION ACCURACY			
600 kHz		± 15	kHz
1,000 kHz		± 30	kHz
1,400 kHz		± 40	kHz
6. AGC FIGURE OF MERIT (-10 dB)			
(from 100 mV/m at 1,000 kHz)	45	38	dB

	NOMINAL	LIMIT	UNIT
7. SELECTIVITY (at 1,000 kHz, 200 μ V/m input)	32	25	dB
8. IF REJECTION RATIO (at 600 kHz)	30	22	dB
9. SIGNAL-TO-NOISE RATIO (at 1,000 kHz, 100 mV/m input)	50	40	dB
10. BAND WIDTH (at 1,000 kHz, 5 mV/m input)		6-14	kHz
11. THD (at 1,000 kHz, 5 mV/m input)	0.8	2	%
12. AUDIO RESPONSE at 2 kHz (at 1,000 kHz, 5 mV/m input)		-6	dB
13. AM BEAT (at 2IF/3IF) 1-50 mV/m input	4	10	%
50-100 mV/m input	10	15	%
14. POWER REQUIREMENTS *AC 120V, 60 Hz, 18W.			

*AC 220/240V, 50 Hz for European and Australian Models.

NOTE: Nominal Specs represent the design specs; all units should be able to approximate these—some will exceed and some may drop slightly below these specs. Limit Specs represent the absolute worst condition which still might be considered acceptable; in no case should a unit perform to less than within any Limit Spec.

BLOCK DIAGRAM

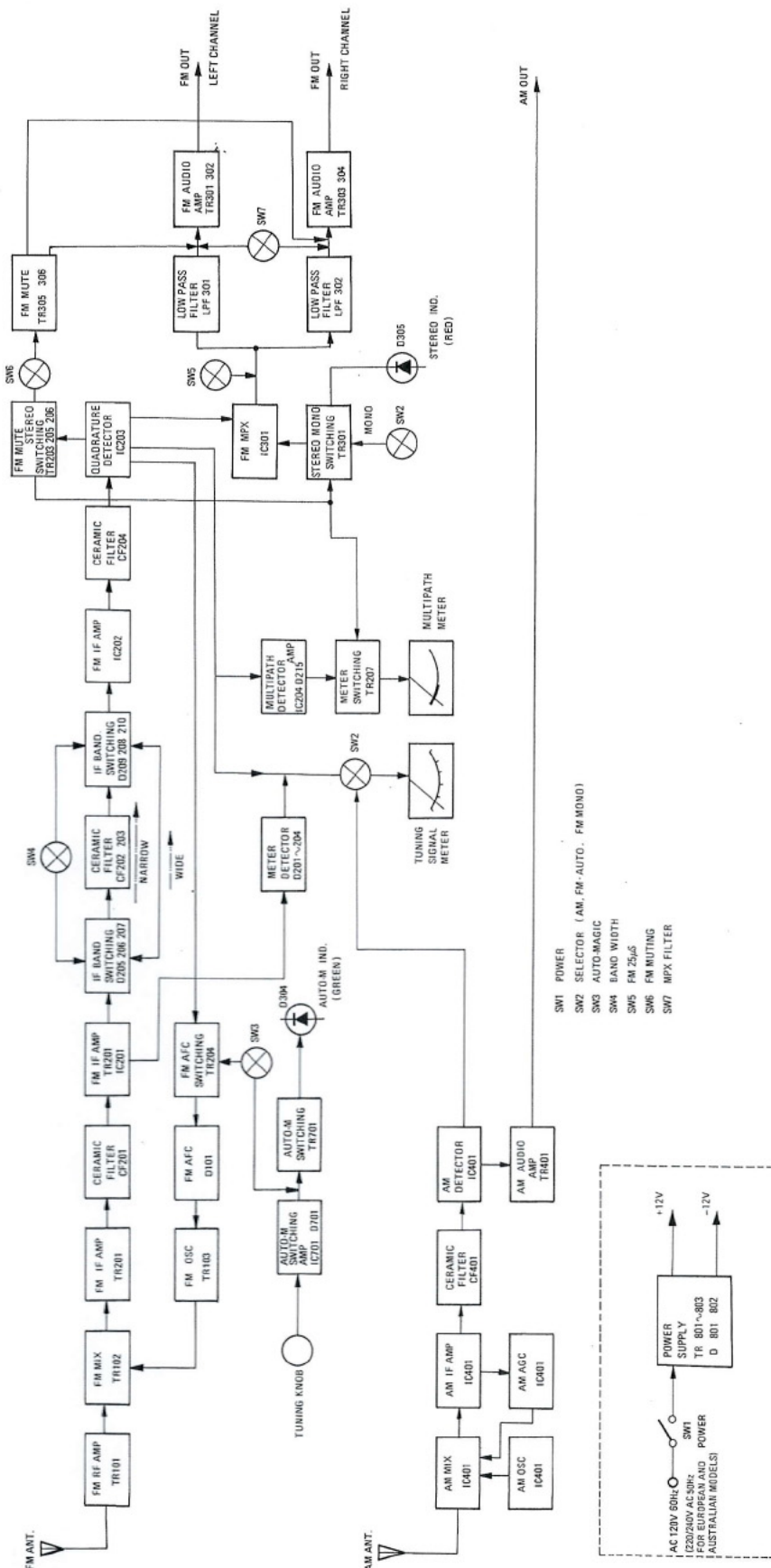

DISASSEMBLY INSTRUCTION

1. **Removing chassis from wooden cabinet.** (Refer to Fig. A)
Remove five screws (#38 & #59) from sides and back.
2. **Removing the Front Panel.** (Refer to Fig. A)
 - a) Pull off the Tuning and Selector knobs.
 - b) Remove four screws (#26) from top and bottom of Front Panel.

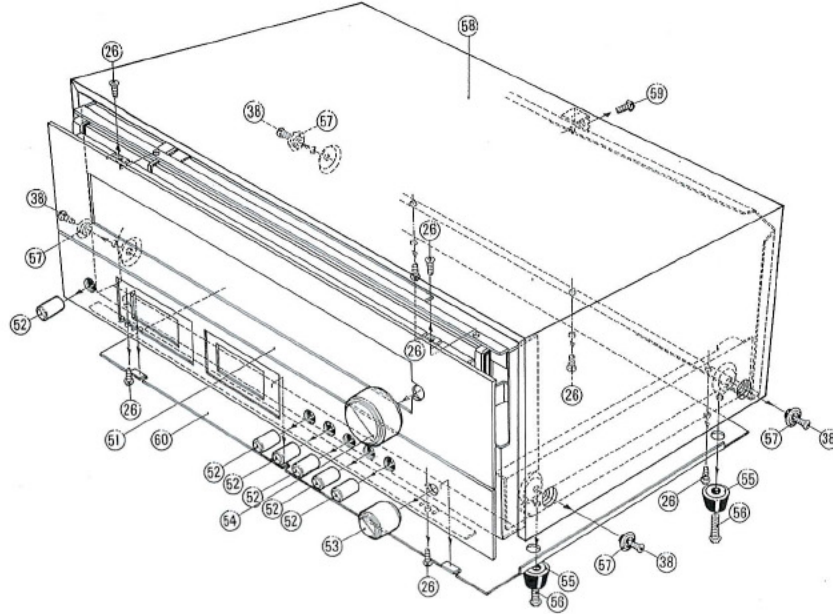

DIAL STRINGING DIAGRAM

Note: Tuning capacitor should be in fully closed position.

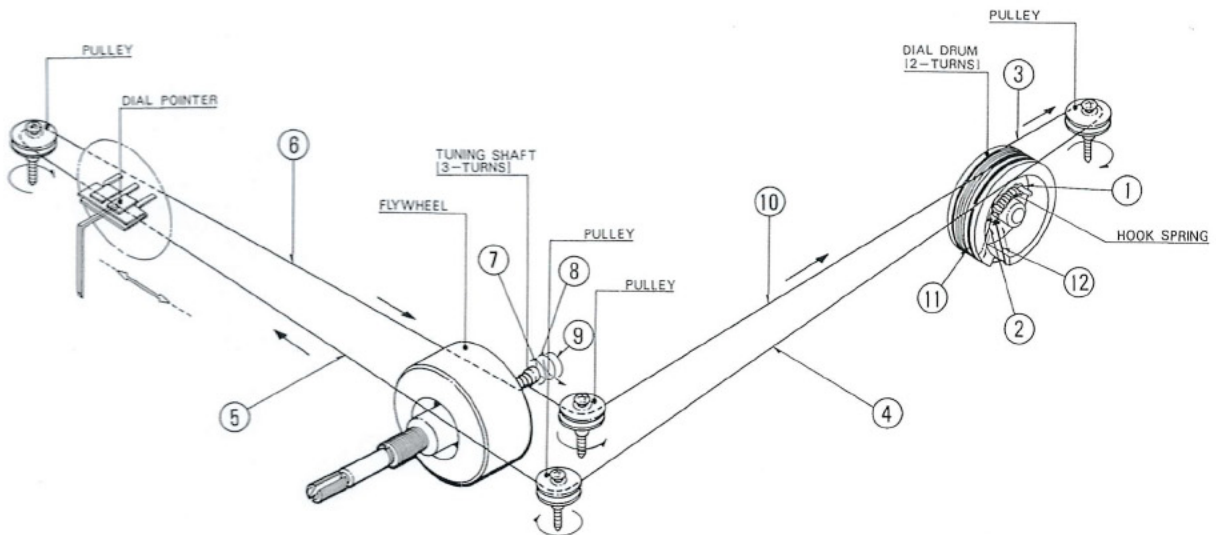

ALIGNMENT PROCEDURES

Do not attempt alignment unless the following equipment is available.

- | | | |
|------------------------|------------------------|----------------------|
| 1. AM Signal Generator | 4. FM Signal Generator | 7. Distortion meter |
| 2. Oscilloscope | 5. Stereo Modulator | 8. DC Voltmeter |
| 3. AC Voltmeter | 6. Audio Generator | 9. Frequency Counter |

Note: Remove line cord antenna from FM external antenna terminal when aligning.

AM IF & RF ALIGNMENT

Output of signal generator should be no higher than necessary to obtain an output reading. Signal Generator Modulation: 30%. Set SELECTOR switch SW1 to AM.						
STEP	SIGNAL GENERATOR COUPLING	SIGNAL GENERATOR FREQUENCY	RECEIVER DIAL SETTING	INDICATOR	ADJUSTMENT Refer Fig. 4.	REMARKS
1	Refer Fig. 1	600 kHz (400 Hz Mod.)	600 kHz	AC Voltmeter to OUTPUT jack	L401 (OSC Coil) L451 (ANT Coil) T401 (IFT)	Adjust for maximum reading.
2	Same as Step 1	1400 kHz (400 Hz Mod.)	1400 kHz	Same as Step 1	TC106 (OSC Trimmer) TC105 (ANT Trimmer)	Same as Step 1
3	Same as Step 1	1000 kHz (400 Hz Mod.)	1000 kHz	Same as Step 1	VR402	Adjust for 320 mV Audio output.
4	Same as Step 1	1000 kHz (400 Hz Mod.)	1000 kHz	Tuner's TUNING Meter	VR401	Adjust for 70% reading of full scale with input of 5 mV/m.

Note: Remove line cord antenna from FM external antenna terminal when aligning.

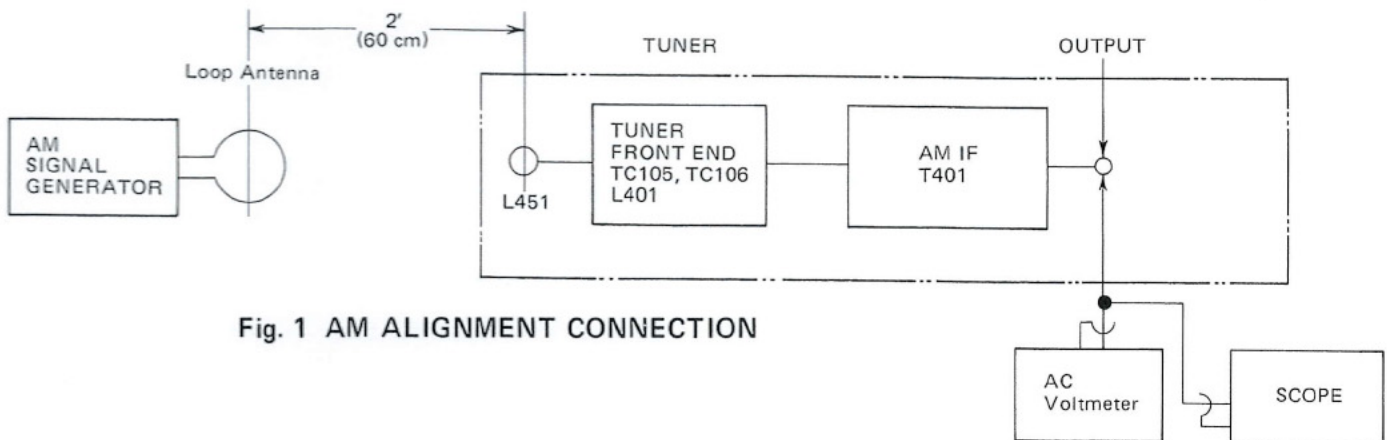

Fig. 1 AM ALIGNMENT CONNECTION

FM RF AND IF ALIGNMENT

Signal generator output should be no higher than necessary to obtain an output reading.
Set Selector switch to FM.

Signal Generator deviation: 75 kHz

NOTE: Be sure to disconnect FM line cord antenna and NARROW B/WIDTH & AUTO-M TUNING buttons should be in the "out" position during alignment.

STEP	SIGNAL GENERATOR COUPLING	SIGNAL GENERATOR FREQUENCY	TUNER DIAL SETTING	INDICATOR	ADJUSTMENT Refer Fig. 4	REMARKS
1	Connect to FM Antenna Terminal through FM Dummy Antenna (300Ω) Fig. 2	No Signal	(on or about 90 MHz)	DC Voltmeter connected to Pin 33 & 34	L202 (Discriminator)	Adjust for 0V reading on DC Voltmeter
2	Same as Step 1	90 MHz (400 Hz, Mod.)	90 MHz	AC Voltmeter connected to OUTPUT jack	L104 (FM OSC Coil) L101 (FM ANT Coil) L102, L103 (FM RF Coil)	Adjust for maximum reading on AC Voltmeter
3	Same as Step 1	106 MHz (400 Hz, Mod.)	106 MHz	Same as Step 2	TC104 (FM OSC Trimmer) TC101 (FM ANT Trimmer) TC102, TC103 (FM RF Trimmer)	Adjust for maximum reading
Repeat steps 2 & 3 until no further improvement is possible.						
4	Same as Step 1	90 MHz (400 Hz, Mod.)	90 MHz	Same as Step 2	T201 (FM IFT)	Adjust for maximum reading
5	Same as Step 1	98 MHz (400 Hz, Mod.)	98 MHz	Distortion Meter connected to OUTPUT jack	L203	Adjust for minimum distortion
6	Same as Step 1	98 MHz (400 Hz, Mod.)	98 MHz	Tuner's TUNING Meter	VR201	Adjust for 70% reading of full scale with input of 1 mV
7	Same as Step 1	98 MHz (400 Hz Mod.)	98 MHz (Press MUTING FM switch)	Oscilloscope connected to OUTPUT jack	VR202	Adjust so output just appears with an input signal level of 8 μV.

For European model, the lowest frequency of FM tuning range should not be below 87.5 MHz.

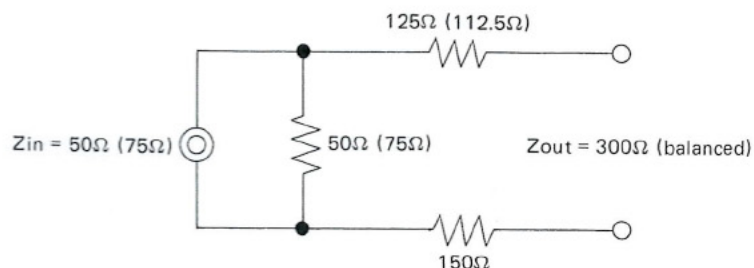

FM Dummy Antenna to 300Ω antenna terminal of Tuner.

Fig. 2 FM DUMMY ANTENNA

MPX ALIGNMENT

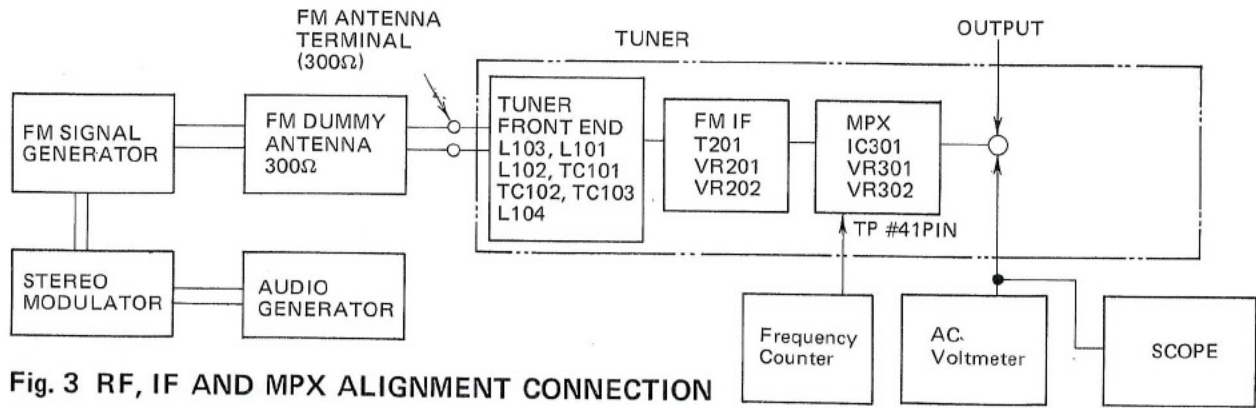

Fig. 3 RF, IF AND MPX ALIGNMENT CONNECTION

Note: Be sure to disconnect FM Line Cord Antenna and NARROW B/WIDTH button should be in the "out" position during alignment.

Set SELECTOR Switch to FM. Tune to center of band. Signal Generator output level: 1000 μ V. Deviation: 75 kHz, at 100 % modulation of composite signal. Connect Signal Generator to FM Antenna Terminal through FM Dummy Antenna (300 Ω).						
STEP	19 kHz (PILOT SIGNAL) MODULATION Level	SIGNAL GENERATOR Freq. Set to	OUTPUT INDICATOR Connected to	ADJUST Refer Fig. 4	ADJUST FOR	NOTE
1	PILOT OFF	Carrier only	Frequency Counter Connect to TP (#41 pin) of PCB 0063 and ground	VR301	19 kHz	
2	8%	Composite 1 kHz R channel	AC Voltmeter to OUTPUT jack of R channel			Adjust input for audio output of about 0.75 V
3	8%	Composite 1 kHz L channel	AC Voltmeter to OUTPUT jack of R channel	VR302	Minimum	AC Voltmeter reading should be at least 32 dB below reading in step 2.
4	8%	Composite 1 kHz R channel	AC Voltmeter to OUTPUT jack of L channel	VR302	Minimum	Same as Step 2.
If you did not obtain - 32 dB readings in steps 3 and 4 (compared with step 2), readjust VR302 until you obtain - 32 dB reading for both steps 3 and 4.						

ALIGNMENT & CHECK POINTS

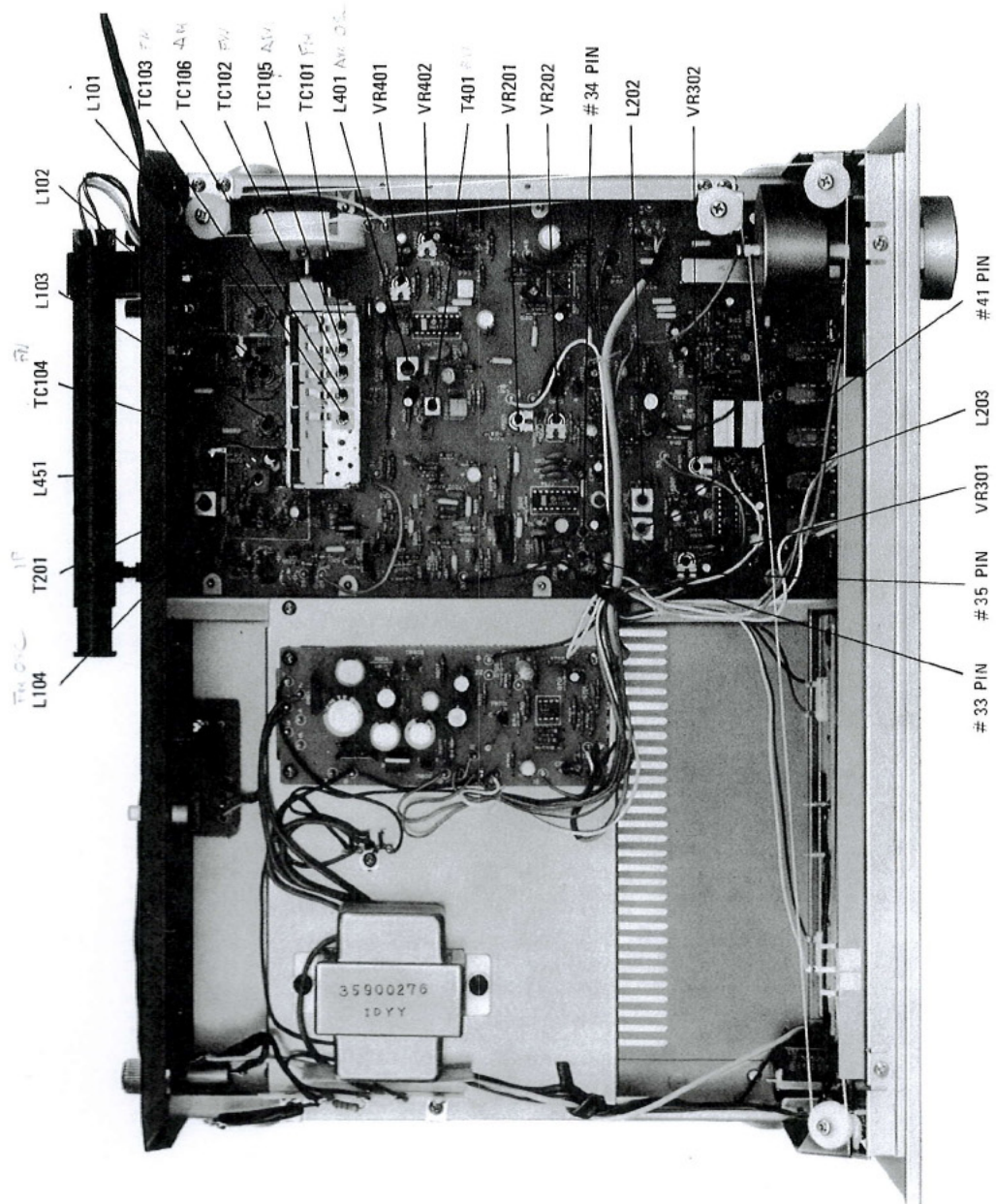

Fig. 4

TROUBLESHOOTING

Symptom	Cause and Remedy
1) Tuner not operative: Pilot lamp does not light.	<ul style="list-style-type: none"> A) Faulty AC power cord Replace the cord. B) Defect in the power switch SW1 Replace the switch. C) Broken wire in the power transformer T851 Replace transformer T851. D) Open power fuse Replace the fuse.
2) Fuse blows when power is turned on.	<ul style="list-style-type: none"> A) Power transformer T851 defective Replace the transformer. B) Short in the primary or secondary of the transformer circuitry Repair the short. C) Damaged rectifier D801 Replace the rectifier. D) Short in the rectifier circuit Repair the short. E) Defective C802 & C803 (short) Replace the capacitor(s).
3) Pilot lamp does not light.	<ul style="list-style-type: none"> A) Defective pilot lamp(s) Replace the lamp(s). B) Open circuit in the transformer T851 tertiary winding Replace the transformer.
4) Pilot lamp lights but no output from either channel.	<ul style="list-style-type: none"> A) Resistor R801, R804 damaged (open) Replace defective resistor(s). B) Capacitor C802, C803 defective (short) Replace the defective capacitor(s). C) Diode D801 damaged Replace the diode. D) Open in secondary winding of power transformer T851 Replace the transformer. E) Transistor TR801 & TR803 damaged (open). Replace the transistor(s).
5) FM does not operate.	<ul style="list-style-type: none"> A) Poor contact in Selector switch SW2 Repair or replace the switch. B) Resistor R307 defective Replace the resistor. C) Capacitor C302 defective Replace the capacitor. D) Defective transistor TR101-TR103, TR201-TR203, TR301-TR401 or IC IC201-IC203, IC301 Replace the defective component(s). E) Defective IFT T201 Replace the IFT. F) Defective resistor R104, R209, R214, R228, R321, R323 Replace the defective resistor(s).

Symptom	Cause and Remedy
	<p>G) Defective capacitor C104, C114, C205, C207, C219, C222, C233, C234 Replace the defective capacitor(s).</p> <p>H) Defective coil L101-L104, L201, L203, L204, L301 Replace the defective coil(s).</p> <p>I) Faulty lead-in Repair or replace the lead-in.</p> <p>J) Diode D207, D208, D209, D211 defective Replace defective diode(s).</p>
<p>6) Multiplex separation not sufficient</p>	<p>A) Deviation in adjustment Readjust VR301 and VR302. (Refer to MPX ALIGNMENT on page 9)</p> <p>B) Transistor TR301-TR304 or IC IC301 defective Replace the defective component(s).</p> <p>C) Variable resistor VR301 or VR302 defective Replace the defective component(s).</p>
<p>7) Stereo indicator LED does not light.</p>	<p>A) Defective indicator LED D305 Replace the LED.</p> <p>B) Deviation in adjustment VR301 Make readjustment. (Refer to MPX ALIGNMENT on page 9)</p> <p>C) Defective transistor TR307 or resistor R306 Replace the defective component(s).</p>
<p>8) FM volume not sufficient</p>	<p>A) If both L and R channels have low volume: Faulty transistor TR101-TR103, TR201, TR202 or IC IC201-IC203 Locate and replace the defective component(s).</p> <p>B) If only one channel has low volume: Defective IC301, TR301 or TR302 in case of L channel, or defective IC301, TR303 or TR304 in case of R channel Replace the defective component(s).</p>
<p>9) AM does not operate.</p>	<p>A) Transistor and IC in AM IF circuit (TR401 or IC401) defective Replace the defective transistor or IC.</p> <p>B) Defective L401, T401, CF401 or T402 in the IF circuit Replace the defective component(s).</p> <p>C) Defective resistor R401, R413 Replace the defective resistor(s).</p> <p>D) Defective capacitor C403, C405, C421 Replace the defective capacitor(s).</p> <p>E) Selector switch SW2 defective Repair or replace the switch.</p> <p>F) Defective Tuning capacitor VC101 Replace the VC101.</p> <p>G) Open in the bar antenna Repair or replace antenna.</p>

Symptom	Cause and Remedy
10) Stereo-mono not effective	A) Defective switch SW2 Replace the switch. B) Transistor TR307 defective Replace the transistor.
11) Muting does not operate.	A) Defective muting switch SW6 Replace the switch. B) Damaged transistor TR203, TR205, TR206, TR305 or TR306 Replace the defective transistor(s).
12) AUTO MAGIC AFC has no effect when AUTO-M switch is ON (Indicator LED does not go out when tuning knob is touched):	A) Transistor TR204, TR701, IC701 defective Replace the defective component(s). B) Resistor R705, R706 defective Replace the defective resistor(s). C) Diode D701, D702 defective Replace the defective diode(s). D) Capacitor C702, C704 defective Replace the defective capacitor(s). E) Defective switch SW3 Replace the switch.
13) Green LED does not light when the tuning control is released.	A) Defective R715 (open), D304 (open) TR701 (short) or IC701 Replace the defective component(s).
14) NARROW B/WIDTH not effective	A) Diode D205, D206, D210 defective Replace the defective diode(s). B) Defective switch SW4 Replace the switch. C) Defective ceramic filter CF202, CF203 Replace the filter(s).
15) MULTIPATH Meter does not function.	A) Defective meter M2 Replace the meter. B) Defective IC204, TR205-TR207 Replace the defective component(s). C) Capacitor C242, C243, C246, C247 defective Replace the defective capacitor(s). D) Diode D215, D216 defective Replace the defective diode(s).

0063 TUNER BOARD

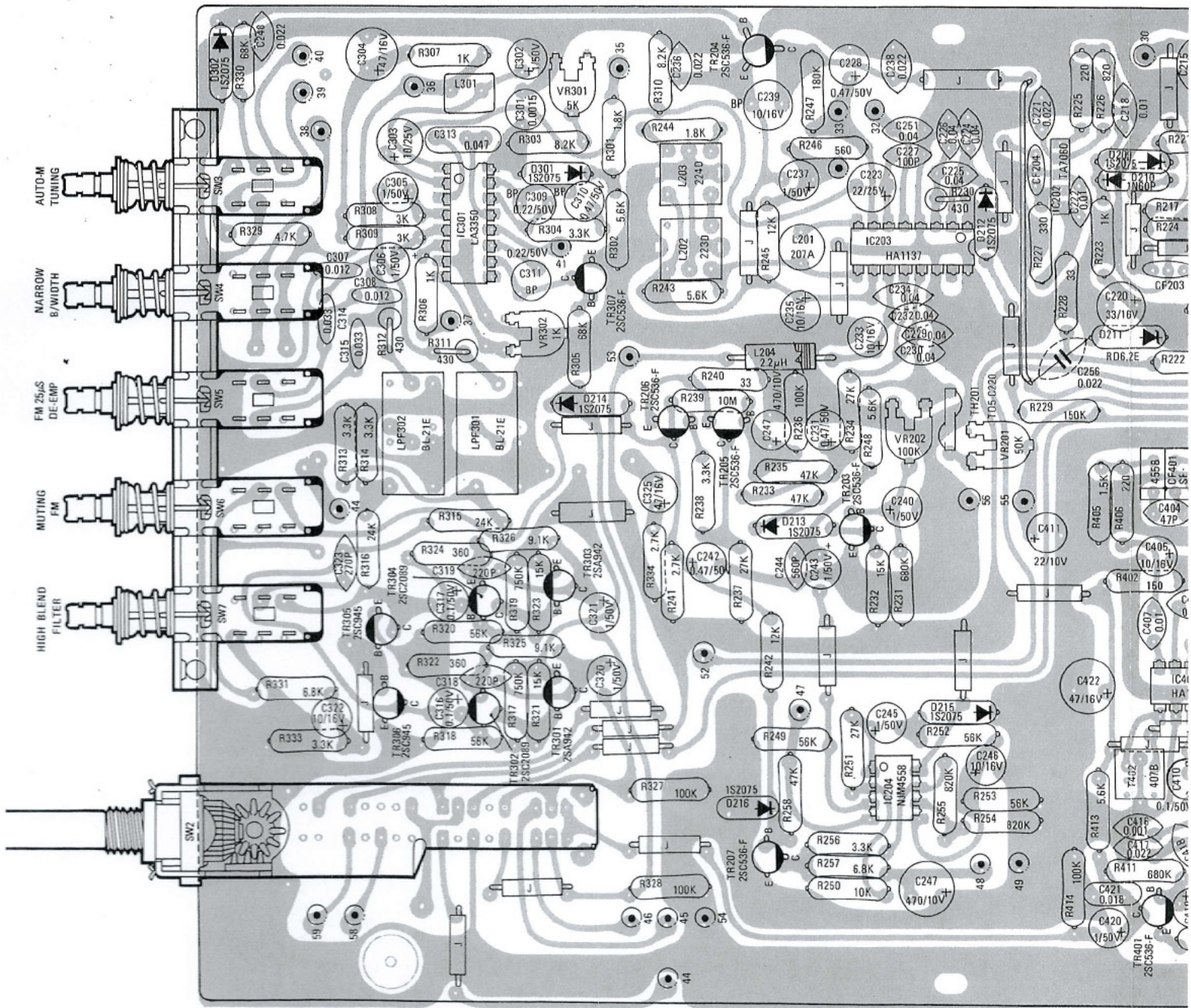

RD(TOP VIEW)

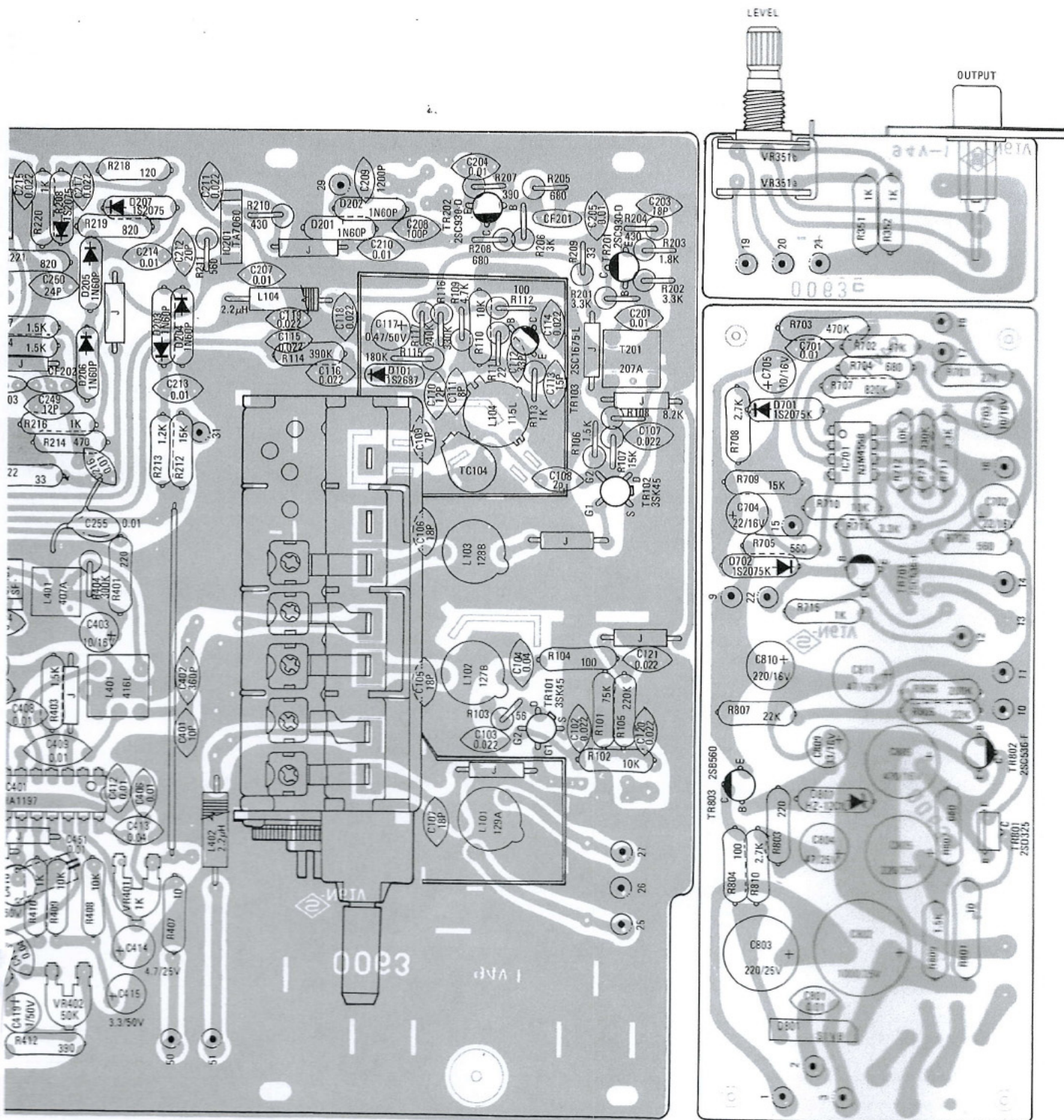

BOARD (BOTTOM VIEW)

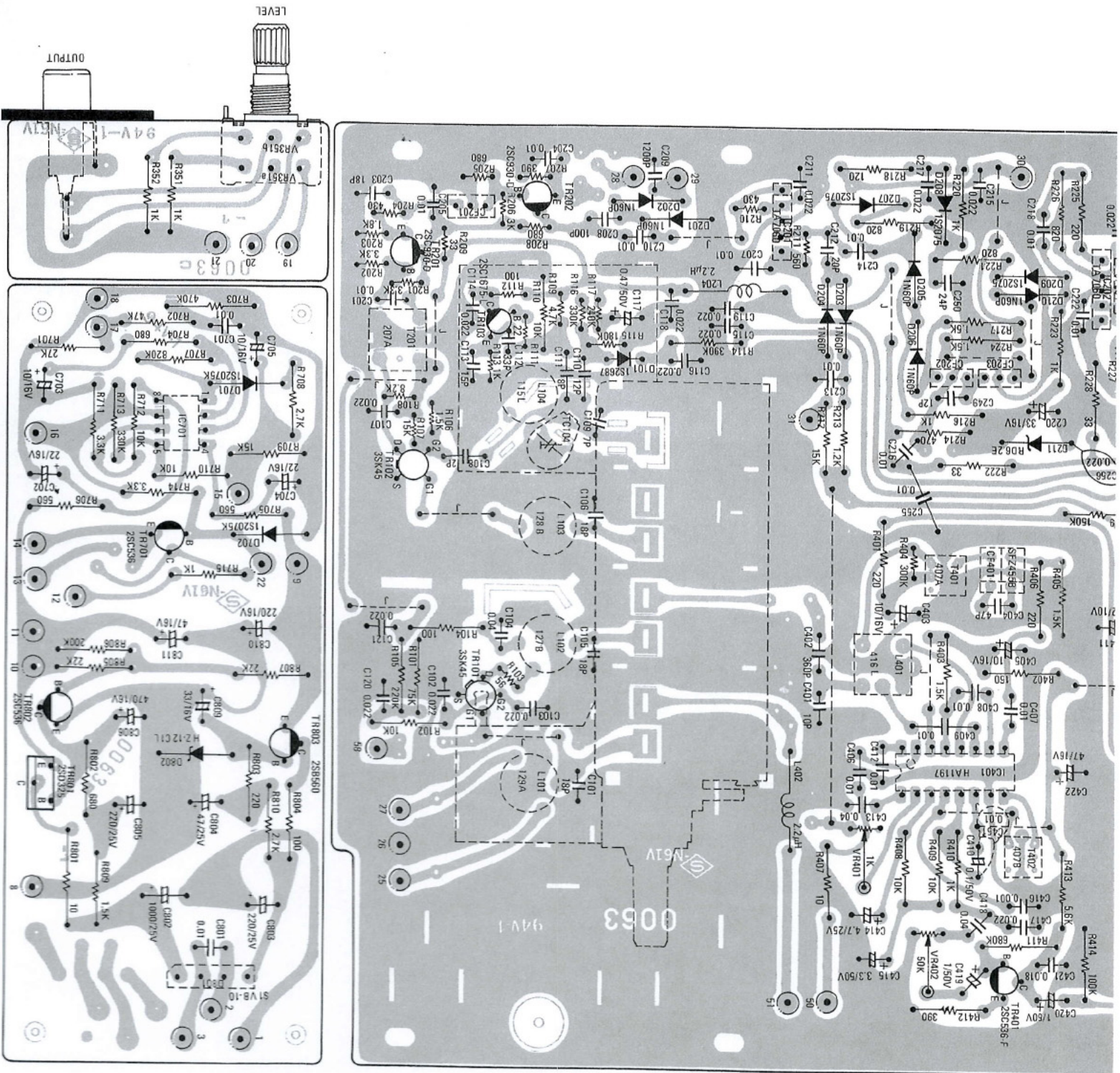

Ref. No.	Value (F)	R/S Part No.	Voltage (V)	Tolerance (%)	Material
C301	1500P		50	±10	Polystyrene
C302	1μ		50	+75 -10	Electrolytic
C303	10μ		25	+50 -10	Electrolytic
C304	47μ		16	+50 -10	Electrolytic
C305	1μ		50	+75 -10	Electrolytic
C306	1μ		50	+75 -10	Electrolytic
C307	0.012μ		50	±10	Polyester
C308	0.012μ		50	±10	Polyester
C309	0.22μ		50	±20	Electrolytic
C310	0.47μ		50	±20	Electrolytic
C311	0.22μ		50	±20	Electrolytic
C312	Not Used				
C313	0.047μ		50	±10	Polyester
C314	*0.033μ		50	±10	Polyester
C315	*0.033μ		50	±10	Polyester
C316	0.1μ		50	+75 -10	Electrolytic
C317	0.1μ		50	+75 -10	Electrolytic
C318	220P	CF-1503	50	±10	Ceramic
C319	220P	CF-1503	50	±10	Ceramic
C320	1μ		50	+75 -10	Electrolytic
C321	1μ		50	+75 -10	Electrolytic
C322	10μ		16	+50 -10	Electrolytic
C323	270P	CF-1503	50	±10	Ceramic
C324	Not Used				
C325	47μ		16	+50 -10	Electrolytic
C401	10P		50	±0.5PF	Ceramic
C402	360P	CF-1516	50	±10	Ceramic
C403	10μ		16	+50 -10	Electrolytic
C404	47P	CF-1366	50	±10	Ceramic
C405	10μ		16	+50 -10	Electrolytic
C406	0.01μ	CF-1746	25	+80 -20	Ceramic
C407	0.01μ	CF-1746	25	+80 -20	Ceramic
C408	0.01μ	CF-1746	25	+80 -20	Ceramic
C409	0.01μ	CF-1699	50	±10	Ceramic
C410	0.1μ		50	+75 -10	Electrolytic
C411	22μ		10	+50 -10	Electrolytic
C412	0.01μ	CF-1746	25	+80 -20	Ceramic
C413	0.04μ	CF-1786	25	+80 -20	Ceramic

Ref. No.	Value (F)	R/S Part No.	Voltage (V)	Tolerance (%)	Material
C414	4.7μ		25	+75 -10	Electrolytic
C415	3.3μ		50	+75 -10	Electrolytic
C416	1000P	CF-1553	50	±10	Ceramic
C417	0.022μ		25	+80 -20	Ceramic
C418	0.04μ	CF-1786	25	+80 -20	Ceramic
C419	1μ		50	+75 -10	Electrolytic
C420	1μ		50	+75 -10	Electrolytic
C421	0.018μ		25		
C422	47μ		16	+50 -10	Electrolytic
C451	0.01μ	CF-1746	25	+80 -20	Ceramic
C701	0.01μ	CF-1746	25	+80 -20	Ceramic
C702	22μ		16	+50 -10	Electrolytic
C703	10μ		16	+50 -10	Electrolytic
C704	22μ		16	+50 -10	Electrolytic
C705	10μ		16	+50 -10	Electrolytic
C801	0.01μ	CF-1746	25	+80 -20	Ceramic
C802	1000μ		25	+50 -10	Electrolytic
C803	220μ		25	+50 -10	Electrolytic
C804	47μ		25	+50 -10	Electrolytic
C805	220μ		25	+50 -10	Electrolytic
C806	470μ		16	+50 -10	Electrolytic
C807	Not Used				
C808	Not Used				
C809	33μ		16	+50 -10	Electrolytic
C810	220μ		16	+50 -10	Electrolytic
C811	47μ		16	+50 -10	Electrolytic
*C851	0.022μ		250	±20	Polyester
*C852	0.022μ		250	±20	Polyester

* C851, C852: for European and Australian models only

CERAMIC FILTERS

Ref. No.	Description	R/S Part No.	Mfr's Part No.
CF201	For FM 10.7ML-M8	C-0926	35300026
CF202	For FM 10.7ML-M8	C-0926	35300026
CF203	For FM 10.7ML-M8	C-0926	35300026
CF204	For FM 10.7ML-M8	C-0926	35300026
CF401	For AM SF455B	C-0869	35300023

*0.015μ for European and Australian models

COILS & TRANSFORMERS

Ref. No.	Description	R/S Part No.	Mfr's Part No.
L101	FM Ant. Coil 129A	CA-3965	35501311
L102	FM RF Coil 127B	CA-4906	35501342
L103	FM RF Coil 128B	CA-4907	35501352
L104	FM OSC Coil 115L	CA-4674	35501206
L105	Choke Coil 2.2 μ H	CB-2376	35102228
L201	Choke Coil 22 μ H		35125220
L202	Quadrature Coil 223D	CA-3948	35702234
L203	Quadrature Coil 224D	CA-3949	35702244
L204	Choke Coil 2.2 μ H	CB-2376	35102228
L301	Choke Coil 144LY-330K	CB-2402	35105330
L401	AM OSC Coil 416L	CA-4910	35504176
L402	Choke Coil 2.2 μ H	CB-2376	35102228
L403	Choke Coil		35199002
L451	AM Bar Antenna Coil	CA-0668	35400551
T201	FM IFT Coil 207A	CA-7830	35702081
T401	AM IFT 407A	CA-7854	35704081
T402	AM IFT 407B	CA-7835	35704082
T851	Power Transformer	TA-0679	35900276
T851	Power Transformer (Europe/Australia)		35900289

CR COMPONENT

Ref. No.	Description	R/S Part No.	Mfr's Part No.
CR851	Spark Killer (UL)		43000020
CR851	Spark Killer (CSA)		43000017

DIODES

Ref. No.	Type No.	R/S Part No.	Mfr's Part No.	Manufacturer
D101	1S2687	DX-0302	30600560	JRC
D201	1N60P	DX-0162	30600011	UNIZON
D202	1N60P	DX-0162	30600011	UNIZON
D203	1N60P	DX-0162	30600011	UNIZON
D204	1N60P	DX-0162	30600011	UNIZON
D205	1N60P	DX-0162	30600011	UNIZON
D206	1N60P	DX-0162	30600011	UNIZON
D207	1S2075K		30601001	Hitachi
D208	1S2075K		30601001	Hitachi
D209	1S2075K		30601001	Hitachi
D210	1N60P	DX-0162	30600011	UNIZON
D211	RD6.2E	DX-0501	30600691	NEC
D212	1S2075K		30601001	Hitachi
D213	1S2075K		30601001	Hitachi
D214	1S2075K		30601001	Hitachi
D215	1S2075K		30601001	Hitachi
D216	1S2075K		30601001	Hitachi
D301	1S2075K		30601001	Hitachi
D302	1S2075K		30601001	Hitachi
D304	BU1109G	L-0923	30601241	Stanley
D305	BU1109R	L-0922	30601221	Stanley
D701	1S2075K		30601001	Hitachi
D702	1S2075K		30601001	Hitachi
D801	S1VB-10	DX-1121	30601061	Shindengen
D802	HZ-12C1L		30601351	Hitachi

FILTERS

Ref. No.	Description	R/S Part No.	Mfr's Part No.
LPF301	Low Pass Filter BL-21E	C-0864	35000080
LPF302	Low Pass Filter BL-21E	C-0864	35000080

INTEGRATED CIRCUITS

Ref. No.	Type No.	R/S Part No.	Part No.	Manufacturer
IC201	TA7060P	MX-3356	30900300	Toshiba
IC202	TA7060P	MX-3356	30900300	Toshiba
IC203	HA1137	MX-3546	30900450	Hitachi
IC204	NJM4558D	MX-3449	30900361	JRC
IC301	LA3350	MX-3215	30900310	Sanyo
IC401	HA1197	MX-3467	30900400	Hitachi
IC701	NJM4558D	MX-3449	30900361	JRC

LAMPS

Ref. No.	Description	R/S Part No.	Mfr's Part No.
PL1	BF311-03030A 8V, 250mA	L-0351	37008006
PL2	BF310-03030A 8V, 250mA	D-1245	37008019
PL3	BF310-03030A 8V, 250mA	D-1245	37008019

METERS

Ref. No.	Description	R/S Part No.	Mfr's Part No.
M1	TUNING Meter 300 μ A	M-0394	60300001
M2	MULTIPATH Meter 300 μ A	M-0395	60300002

P.C. BOARD ASSEMBLIES

Ref. No.	Description	R/S Part No.	Mfr's Part No.
0063A	Tuner Board	X7796	97006310
0063B	Power Supply Board	X7796	97006310
0063C	Output Board	X7796	97006310
7169	Meter Lamp Board		97716910

RESISTORS

Ref. No.	Value (Ω)	R/S Part No.	Wattage (W)	Tolerance (%)	Material
R101	75K		1/4	± 5	Carbon
R102	10K		1/4	± 5	Carbon
R103	56		1/4	± 5	Carbon
R104	100		1/4	± 5	Carbon
R105	220K		1/4	± 5	Carbon
R106	1.5K		1/4	± 5	Carbon
R107	15K		1/4	± 5	Carbon
R108	8.2K		1/4	± 5	Carbon
R109	4.7K		1/4	± 5	Carbon
R110	10K		1/4	± 5	Carbon
R111	22		1/4	± 5	Carbon
R112	100		1/4	± 5	Carbon
R113	1K		1/4	± 5	Carbon
R114	390K		1/4	± 5	Carbon
R115	180K		1/4	± 5	Carbon
R116	330K		1/4	± 5	Carbon
R117	240K		1/4	± 5	Carbon
R201	3.3K		1/4	± 5	Carbon
R202	3.3K		1/4	± 5	Carbon
R203	1.8K		1/4	± 5	Carbon
R204	430		1/4	± 5	Carbon
R205	680		1/4	± 5	Carbon
R206	3K		1/4	± 5	Carbon
R207	390		1/4	± 5	Carbon
R208	680		1/4	± 5	Carbon
R209	33		1/4	± 5	Carbon
R210	430		1/4	± 5	Carbon
R211	560		1/4	± 5	Carbon
R212	15K		1/4	± 5	Carbon
R213	1.2K		1/4	± 5	Carbon
R214	470		1/4	± 5	Carbon
R215	Not Used				
R216	1K		1/4	± 5	Carbon
R217	1.5K		1/4	± 5	Carbon
R218	120		1/4	± 5	Carbon
R219	820		1/4	± 5	Carbon
R220	1K		1/4	± 5	Carbon

Ref. No.	Value (Ω)	R/S Part No.	Wattage (W)	Tolerance (%)	Material
R221	820		1/4	±5	Carbon
R222	33		1/4	±5	Carbon
R223	1K		1/4	±5	Carbon
R224	1.5K		1/4	±5	Carbon
R225	220		1/4	±5	Carbon
R226	820		1/4	±5	Carbon
R227	330		1/4	±5	Carbon
R228	33		1/4	±5	Carbon
R229	150K		1/4	±5	Carbon
R230	430		1/4	±5	Carbon
R231	680K		1/4	±5	Carbon
R232	15K		1/4	±5	Carbon
R233	47K		1/4	±5	Carbon
R234	27K		1/4	±5	Carbon
R235	47K		1/4	±5	Carbon
R236	100K		1/4	±5	Carbon
R237	27K		1/4	±5	Carbon
R238	3.3K		1/4	±5	Carbon
R239	10M		1/4	±10	Solid
R240	33		1/4	±5	Carbon
R241	2.7K		1/4	±5	Carbon
R242	12K		1/4	±5	Carbon
R243	5.6K		1/4	±5	Carbon
R244	1.8K		1/4	±5	Carbon
R245	12K		1/4	±5	Carbon
R246	560		1/4	±5	Carbon
R247	180K		1/4	±5	Carbon
R248	5.6K		1/4	±5	Carbon
R249	56K		1/4	±5	Carbon
R250	10K		1/4	±5	Carbon
R251	27K		1/4	±5	Carbon
R252	56K		1/4	±5	Carbon
R253	56K		1/4	±5	Carbon
R254	820K		1/4	±5	Carbon
R255	820K		1/4	±5	Carbon
R256	3.3K		1/4	±5	Carbon
R257	6.8K		1/4	±5	Carbon
R258	47K		1/4	±5	Carbon
R301	1.8K		1/4	±5	Carbon
R302	5.6K		1/4	±5	Carbon
R303	8.2K		1/4	±5	Carbon
R304	3.3K		1/4	±5	Carbon
R305	68K		1/4	±5	Carbon
R306	1K		1/4	±5	Carbon
R307	1K		1/4	±5	Carbon
R308	3K		1/4	±5	Carbon
R309	3K		1/4	±5	Carbon
R310	8.2K		1/4	±5	Carbon
R311	430		1/4	±5	Carbon
R312	430		1/4	±5	Carbon
R313	3.3K		1/4	±5	Carbon
R314	3.3K		1/4	±5	Carbon

Ref. No.	Value (Ω)	R/S Part No.	Wattage (W)	Tolerance (%)	Material
R315	24K		1/4	±5	Carbon
R316	24K		1/4	±5	Carbon
R317	750K		1/4	±5	Carbon
R318	56K		1/4	±5	Carbon
R319	750K		1/4	±5	Carbon
R320	56K		1/4	±5	Carbon
R321	15K		1/4	±5	Carbon
R322	360		1/4	±5	Carbon
R323	15K		1/4	±5	Carbon
R324	360		1/4	±5	Carbon
R325	9.1K		1/4	±5	Carbon
R326	9.1k		1/4	±5	Carbon
R327	100K		1/4	±5	Carbon
R328	100K		1/4	±5	Carbon
R329	4.7K		1/4	±5	Carbon
R330	68K		1/4	±5	Carbon
R331	6.8K		1/4	±5	Carbon
R332	Not Used				
R333	3.3K		1/4	±5	Carbon
R334	2.7K		1/4	±5	Carbon
R351	1K		1/4	±5	Carbon
R352	1K		1/4	±5	Carbon
R401	220		1/4	±5	Carbon
R402	150		1/4	±5	Carbon
R403	1.5K		1/4	±5	Carbon
R404	300K		1/4	±5	Carbon
R405	1.5K		1/4	±5	Carbon
R406	220		1/4	±5	Carbon
R407	10		1/4	±5	Carbon
R408	10K		1/4	±5	Carbon
R409	10K		1/4	±5	Carbon
R410	1K		1/4	±5	Carbon
R411	680K		1/4	±5	Carbon
R412	390		1/4	±5	Carbon
R413	5.6K		1/4	±5	Carbon
R414	100K		1/4	±5	Carbon
R701	27K		1/4	±5	Carbon
R702	47K		1/4	±5	Carbon
R703	470K		1/4	±5	Carbon
R704	680		1/4	±5	Carbon
R705	560		1/4	±5	Carbon
R706	560		1/4	±5	Carbon
R707	820K		1/4	±5	Carbon
R708	2.7K		1/4	±5	Carbon
R709	15K		1/4	±5	Carbon
R710	10K		1/4	±5	Carbon
R711	3.3K		1/4	±5	Carbon
R712	10K		1/4	±5	Carbon
R713	330K		1/4	±5	Carbon
R714	3.3K		1/4	±5	Carbon
R715	1K		1/4	±5	Carbon

Ref. No.	Value (Ω)	R/S Part No.	Wattage (W)	Tolerance (%)	Material
R801	10		1/4	± 5	Carbon
R802	680		1/4	± 5	Carbon
R803	220		1/4	± 5	Carbon
R804	100		1/4	± 5	Carbon
R805	22K		1/4	± 5	Carbon
R806	200K		1/4	± 5	Carbon
R807	22K		1/4	± 5	Carbon
R808	Not Used				
R809	1.5K		1/4	± 5	Carbon
R810	2.7K		1/4	± 5	Carbon
*R851	2.2M		1/2	± 10	Solid
R852	10		2	± 10	Wire Wound

* R851: Not Used in European and Australian models

SWITCHES

Ref. No.	Description	R/S Part No.	Mfr's Part No.
SW1	POWER	S-0861	27200110
SW1	POWER (Europe/Australia)		27200112
SW2	SELECTOR	S-0862	27100157
SW3-SW7	Push 5 Keys	S-7383	27200103

THERMISTOR

Ref. No.	Description	R/S Part No.	Mfr's Part No.
TH201	TD5-C220	T-1201	30700120

TRANSISTORS

Ref. No.	Type No.	R/S part No.	Part No.	Manufacturer	Substitute	
					Type No.	Manufacturer
TR101	3SK45		30400071	Hitachi		
TR102	3SK45		30400071	Hitachi		
TR103	2SC1675(L)		30201121	NEC		
TR201	2SC930(D)		30200271	Sanyo		
TR202	2SC930(D)		30200271	Sanyo		
TR203	2SC536(F)		30200131	Sanyo	2SC945	NEC
TR204	2SC536(F)		30200131	Sanyo	2SC945	NEC
TR205	2SC536(f)		30200131	Sanyo	2SC945	NEC
TR206	2SC536(F)		30200131	Sanyo	2SC945	NEC
TR207	2SC536(F)		30200131	Sanyo	2SC945	NEC
TR301	2SA942		30000622	Toshiba		
TR302	2SC2089		30201403	Toshiba		
TR303	2SA942		30000622	Toshiba		
TR304	2SC2089		30201403	Toshiba		
TR305	2SC945		30201031	NEC		
TR306	2SC945		30201031	NEC		
TR307	2SC536(F)		30200131	Sanyo		
TR401	2SC536(F)		30200131	Sanyo	2SC945	NEC
TR701	2SC536(F)		30200131	Sanyo	2SC945	NEC
TR801	2SD325		30300151	Sanyo	2SD330	Sanyo
TR802	2SC536(F)		30200131	Sanyo	2SC945	NEC
TR803	2SB560		30100041	Sanyo	2SB631	Sanyo

VARIABLE CAPACTORS

Ref. No.	Description	R/S Part No.	Mfr's Part No.
VC101	Tuning Capacitor (Include TC101-TC103, TC105 & TC106)	C-4652	26370111
TC104	Trimmer ECV- 6MD34 X 72G	C-0424	26010023

VARIABLE RESISTORS

Ref. No.	Description	R/S Part No.	Mfr's Part No.
VR201	FM Signal Meter Sensitivity Adjust 50 K/B		28101503
VR202	FM Muting & Auto-Stereo Level Adjust 100 K/B	S-0863	28101104
VR301	19 kHz Adjust 5 K/B	P-0840	28101502
VR302	MPX Separation 1 K/B		28101102
VR351a,b	Tuner Output Level Control 10 K/B	P-1893	28000148
VR401	AM Signal Meter Sensitivity Adjust 1 K/B	P-0839	28101102
VR402	AM Output Level Control 50 K/B	S-0864	28101503

MISCELLANEOUS PARTS LIST

Ref. No.	Description	R/S Part No.	Mfr's Part No.
1	Jumper Wire		92000001
2	Shield Plate C	HB-7860	09089001
3	Irrax Tube 0.7 x 15 mm		31140003
4	Wire Wrap Pin 13mm		19044001
5	UL Tube 1 x 10 mm		31501062
6	Shield Plate A	HB-7858	09087001
7	Shield Plate B	HB-7859	09088001
8	Back Panel Assembly		11513A01
9	Bar Antenna Clamp	A-4413	84290001
10	Antenna Terminal Board	J-4533	53032500
11	AC Cord with Plug		62110038
	AC Cord with Plug (Europe)		62110039
	AC Cord with Plug (Australia)		62010013
12	Cord Strain Relief SR-4P4		74089001
13	Fuseholder FH002 (UL)	F-1017	34032001
	Fuseholder N3 (CSA)		34069001
	Fuseholder (Europe/Australia)		34065001
14	Plastic Rivet M3		84254001
15	Fuse 0.5A 125V (UL)	HF-0025	38337105
	Fuse 0.5A (for CSA)		38107105
	Fuse 0.3A 250V (Europe/Australia)		38444203
16	Fiber for Line Cord Ant.		75017002
17	Line Cord Antenna		63101001
18	Front Chassis	Z-4139	03083002
19	Meter Bracket-Panel	HB-7862	63406001
20	Dial Scale Assembly	D-5317	20108001
21	Dial Lamp Socket	J-6576	34072001
22	Tuning Shaft Assembly	D-3252	23056001
23	Plastic Pulley	D-0250	84085001
24	Pulley Shaft		24003002

Ref. No.	Description	R/S Part No.	Mfr's Part No.
25	Binding Head Screw tite C 3 x 5		40000091
26	Binding Head Screw tite 3 x 8		40630081
27	Rubber Sponge for Meter	HB-7864	74156001
28	Rubber for Dial Scale	HB-7863	74155001
29	Dial Scale Mounting Bracket		63412001
30	Lamp Board	D-1245	08060001
31	Screw M3 x 6		40330061
32	Ground Lug		51098002
33	Fiber Washer for Tuning Shaft		74159001
34	Pulley Shaft	HB-5101	24006001
35	Hex Nut 9M		41000004
36	Angle Bracket for Power Transformer	RT-1400	63401002
37	Spring Washer M4		42250441
38	Tapping Screw M4 x 15 Black		40640155
39	Flat Washer M4		42120421
40	Dial Pointer Assembly	D-1246	25048001
41	Mylar for Dial Pointer	RT-1194	84276001
42	Ground Terminal	HB-4106	63319001
43	Wire Clamp		63075001
44	PVC Tube for Wire Clamp		31501426
45	Tapping Screw M3 x 8 Black		40630085
46	Dial Drum	D-0400	21008003
47	Terminal Strip		51100002
48	Spring Washer M3		42250341
49	Fiber Insulator		75066001
50	Spring Coil for Dial Drum		19017001
51	Front Panel Assembly	Z-4141	10513A01
52	Push Button	K-3028	29295001
53	SELECTOR Knob	K-3026	29333001
54	Tuning Knob	K-3030	29293001
55	Plastic Foot		74074001
56	Screw M5 x 15		40350151
57	Plastic Washer for Cabinet		84092001
58	Wooden Cabinet	Z-4142	85083001
59	Brazier Head Screw tite C M3 x 8		40000120
60	Bottom Plate	Z-4135	05056001
61	Light Shield Sponge A		73256001
62	Light Shield Sponge B		73257001
63	2P Pin Jack	J-0974	33021300
64	Center Chassis		01101001
65	Pulley Fit Metal	HB-7866	63428001
66	Pulley Fit Metal	HB-7865	63404001
67	Side Chassis (Right)	Z-4133	04027001
68	Side Chassis (Left)	Z-4140	04028001

HA1197

MX-4737

RADIO SHACK  A DIVISION OF TANDY CORPORATION

U.S.A.: FORT WORTH, TEXAS 76102

CANADA: BARRIE, ONTARIO L4M 4W5

TANDY CORPORATION

AUSTRALIA

280-316 VICTORIA ROAD
RYDALMERE, N.S.W. 2116

BELGIUM

PARC INDUSTRIEL DE NANINNE
5140 NANINNE

U. K.

BILSTON ROAD
WEDNESBURY, WEST MIDLANDS WS10 7JN

#0063A

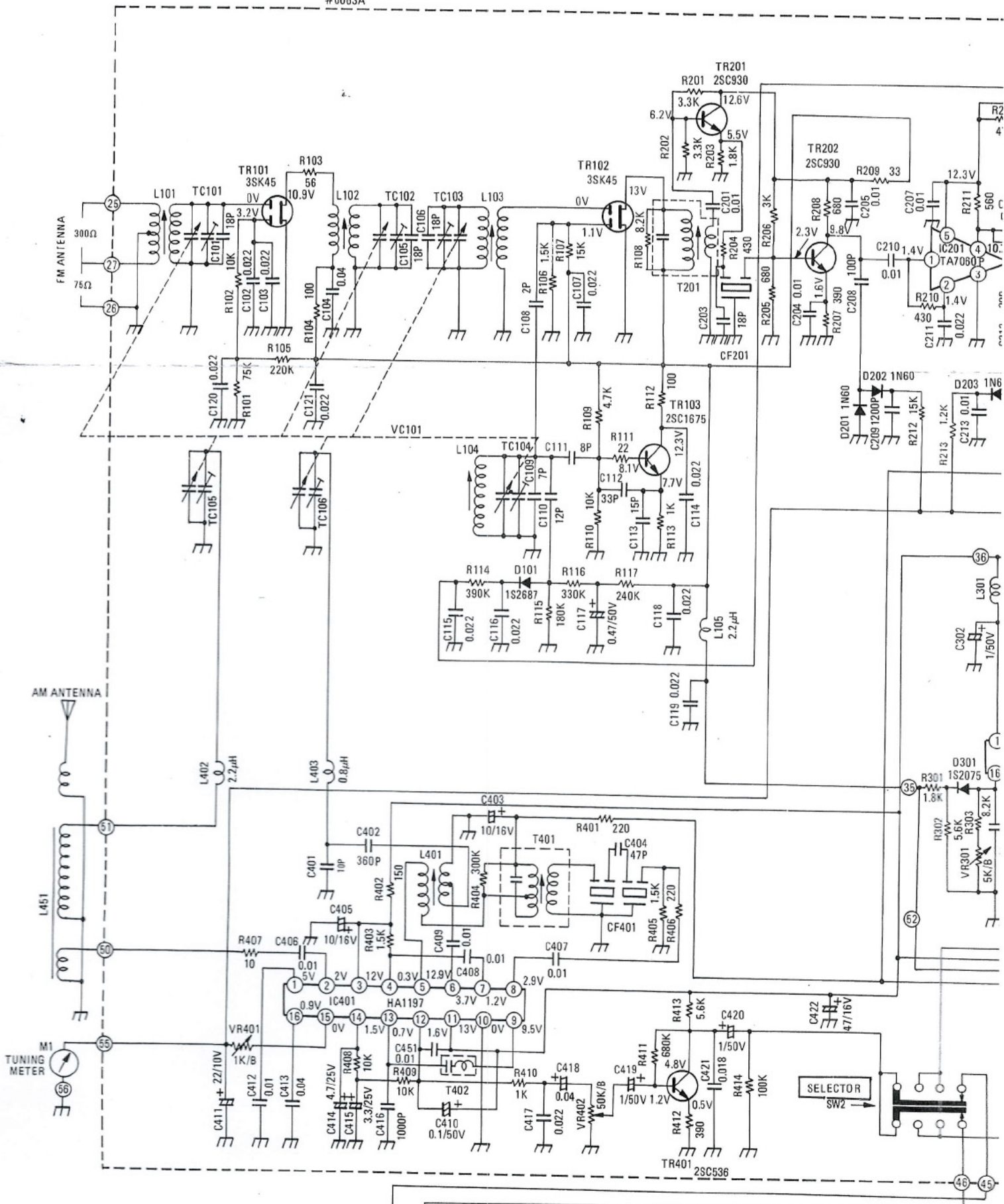

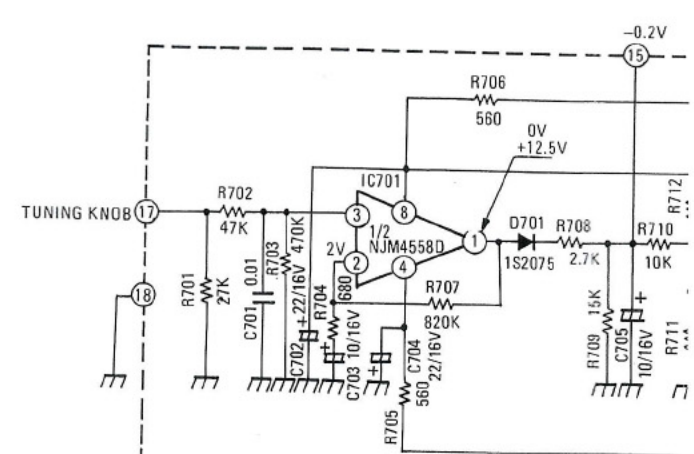
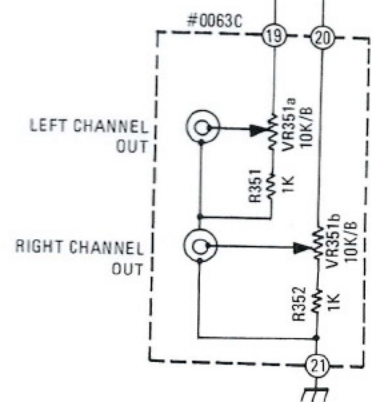
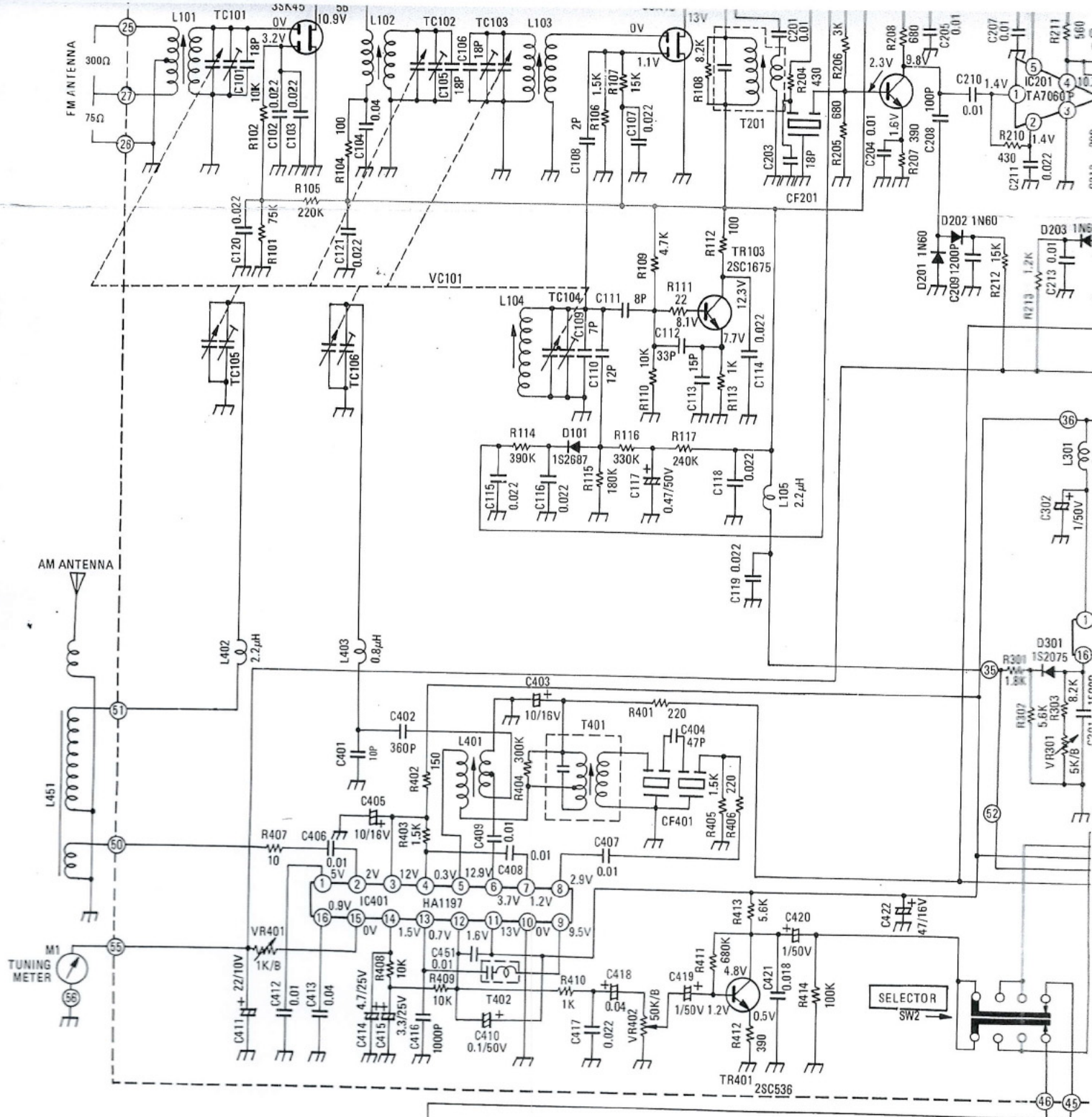

SCHEMATIC DIAGRAM

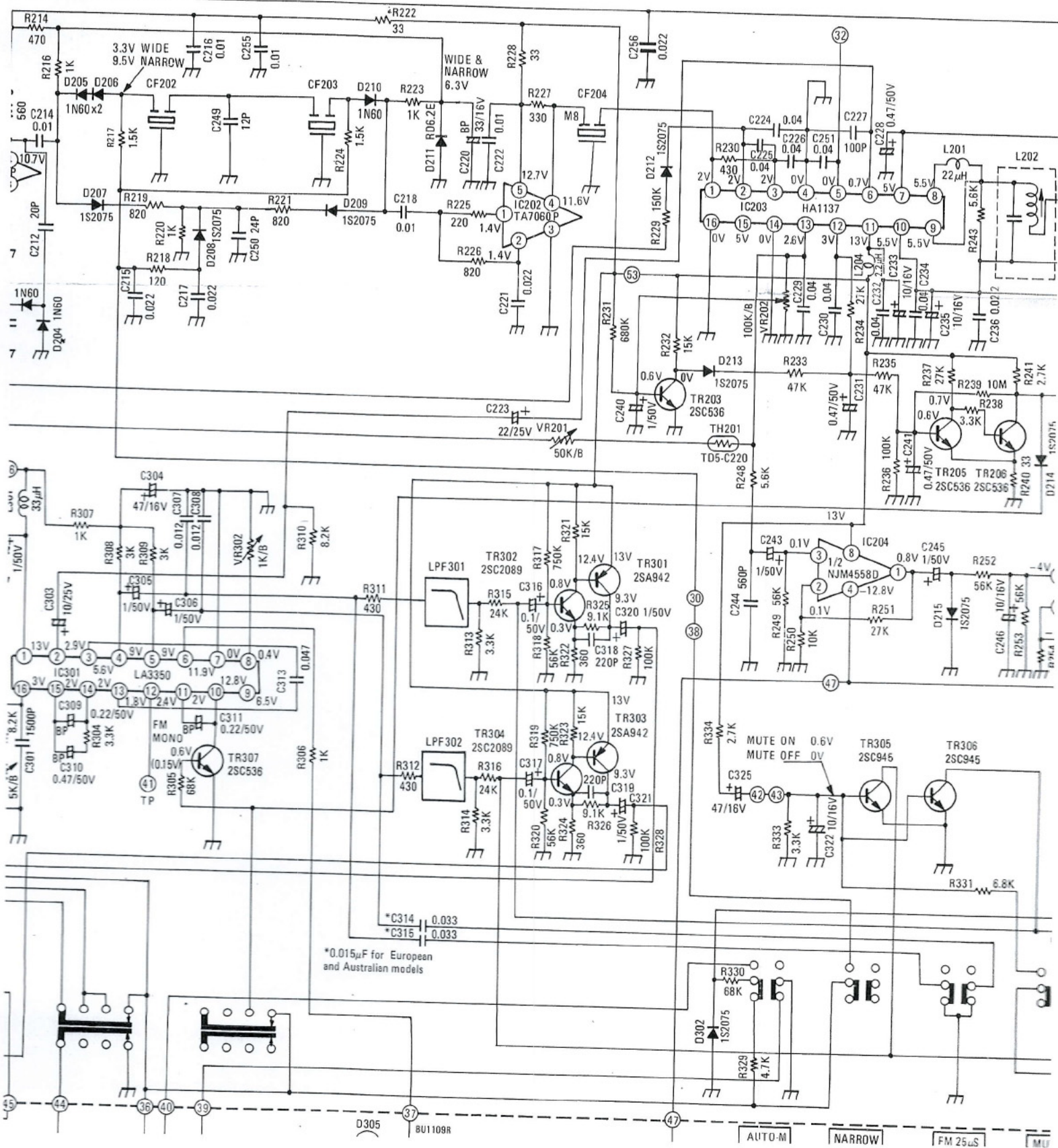

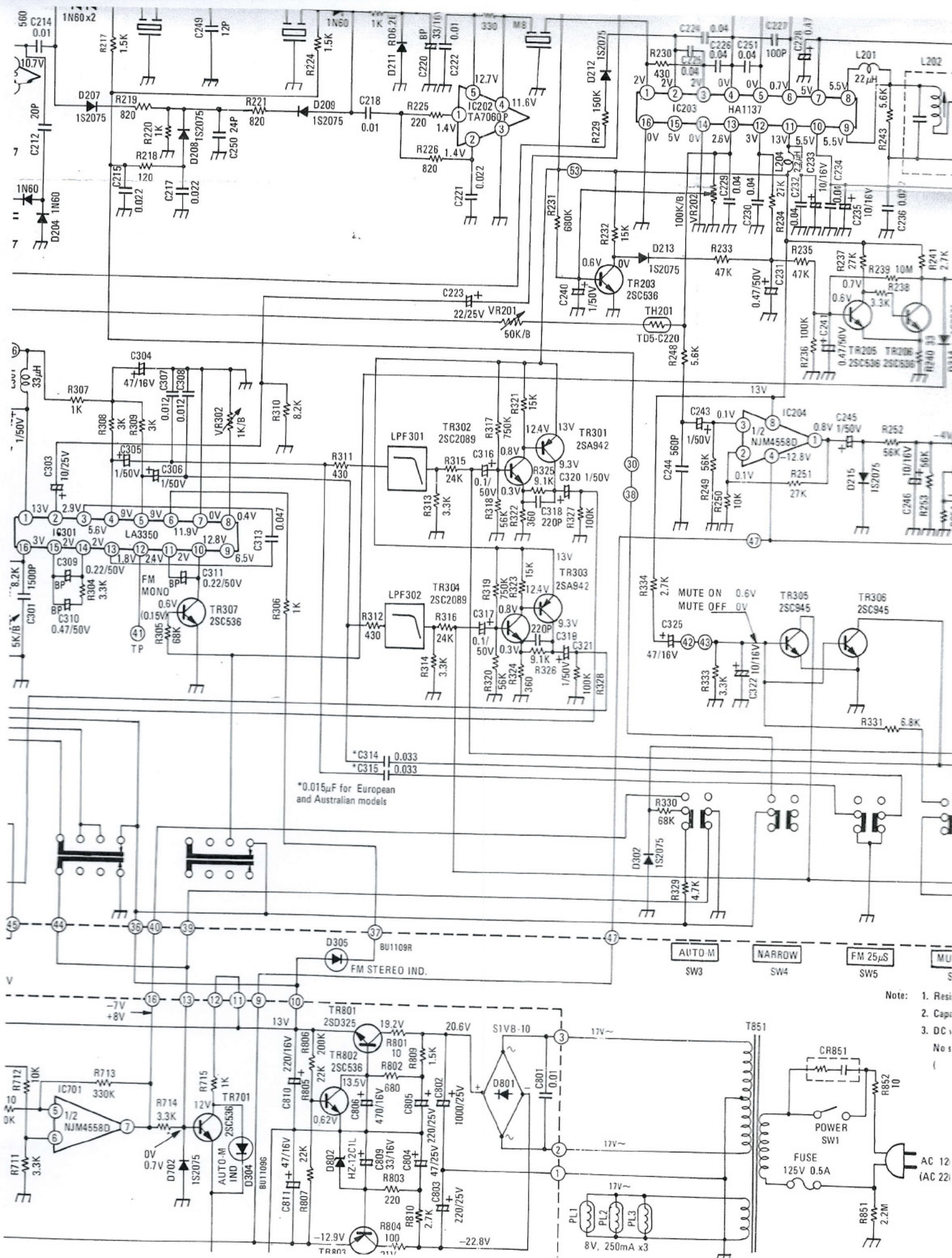

*0.015μF for European and Australian models

- Note: 1. Resistor
2. Capacitor
3. DC Voltage

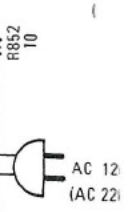

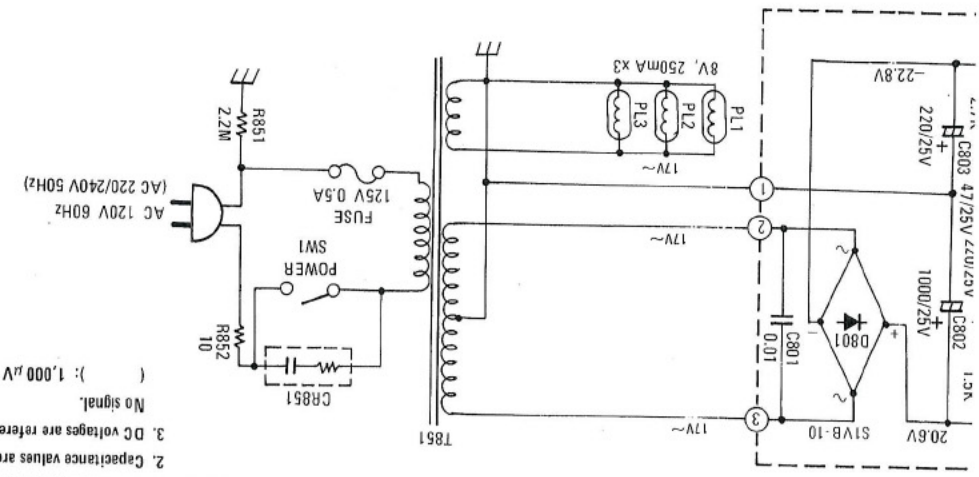
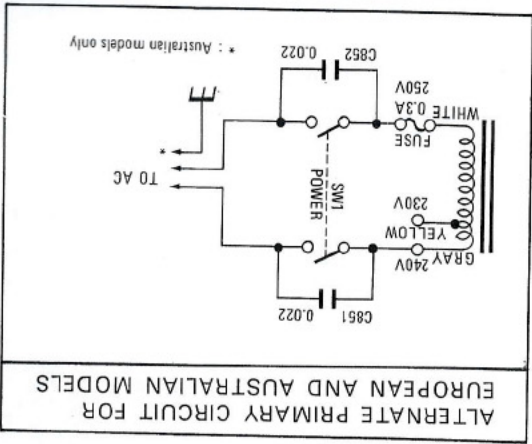

Note:

1. Resistance values are indicated in ohms unless otherwise specified (K=1,000, M=1,000,000).
2. Capacitance values are shown in microfarads unless otherwise noted (P=picofarads).
3. DC voltages are referred to ground under the following conditions:
 () No signal.
 () 1,000 μ V FM stereo signal.

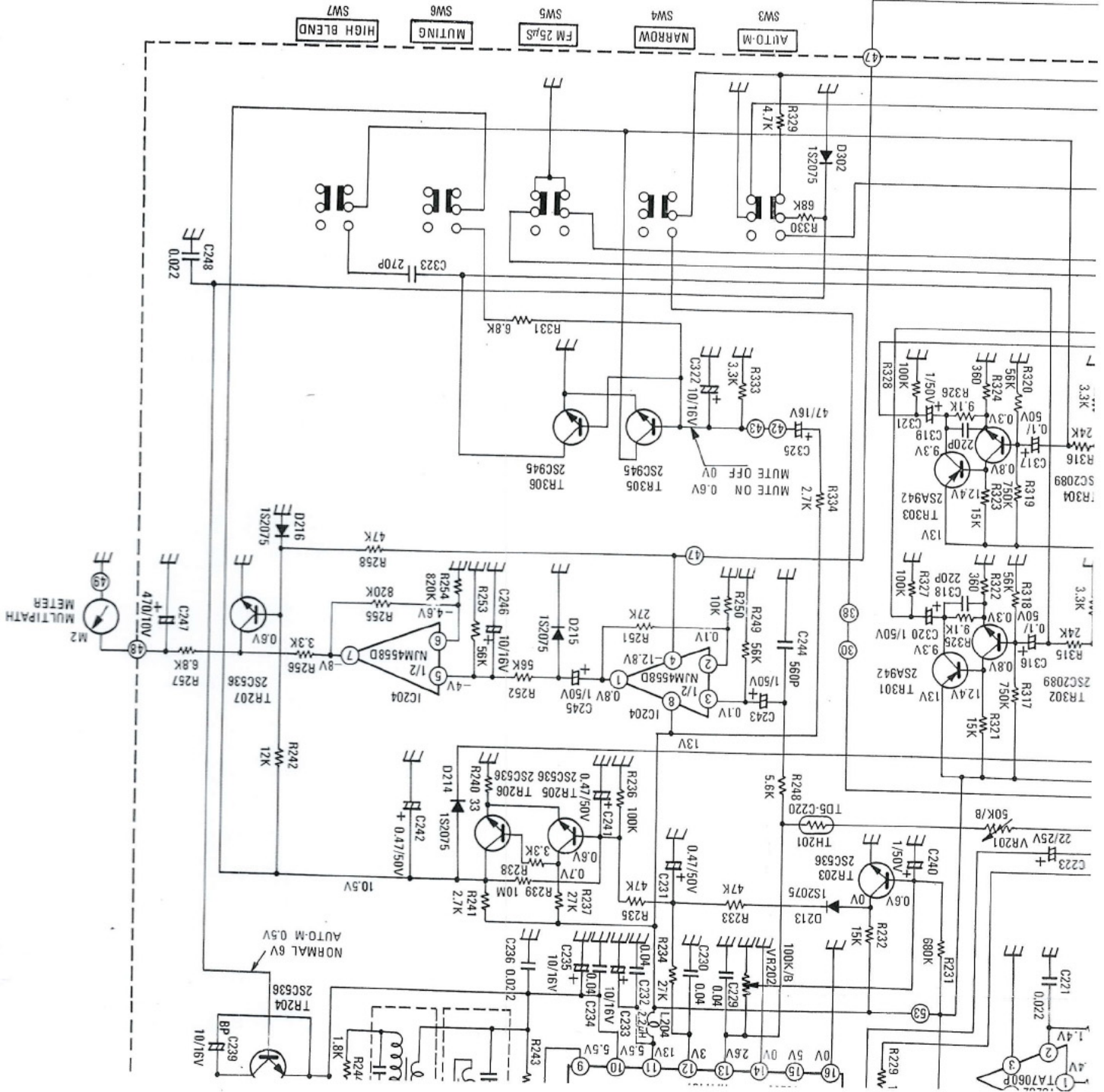

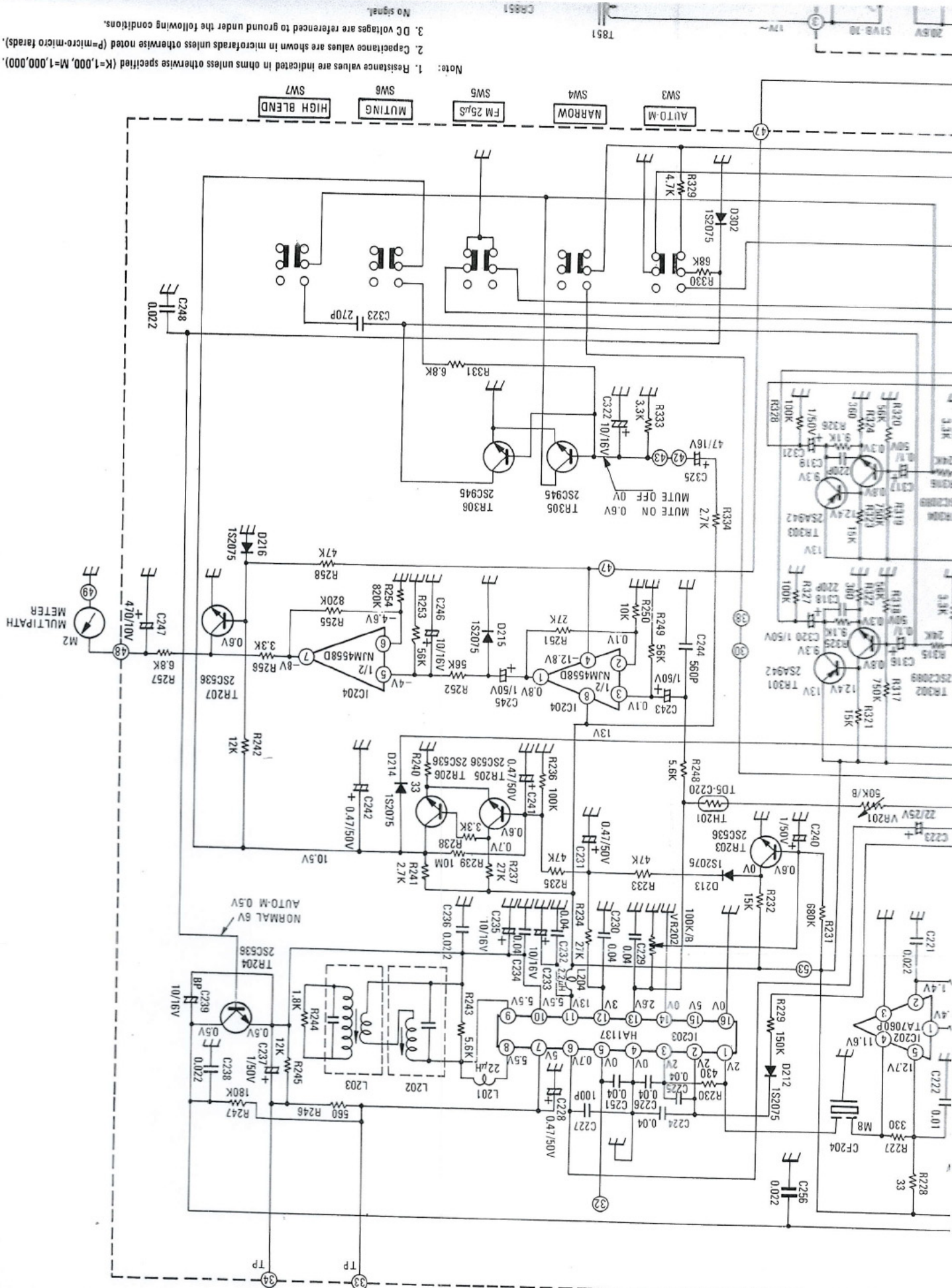

Note: 1. Resistance values are indicated in ohms unless otherwise specified (K=1,000, M=1,000,000).
 2. Capacitance values are shown in microfarads unless otherwise noted (P=micro-micro farads).
 3. DC voltages are referred to ground under the following conditions.

CR651

205V 51V8-10 17V- 1851

