

Service Manual

AV Control Stereo Receiver



Receiver

SA-EX900

Colour

(K) Black Type

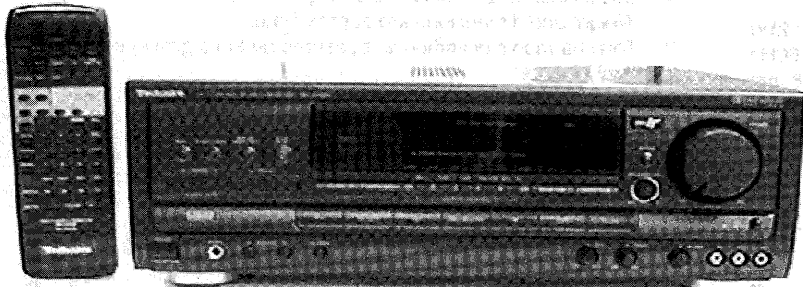

Area

Suffix for Model No.	Area	Colour
(P)	U.S.A.	(K)
(PC)	Canada	

* Manufactured under license from Dolby Laboratories Licensing Corporation. Additionally licensed under one or more of the following patents: U.S. numbers 3,632,886, 3,746,792 and 3,959,590; Canada numbers 1,004,603 and 1,037,877.

"Dolby" and the double-D symbol are trademarks of Dolby Laboratories Licensing Corporation.

Specifications

FM Tuner Section

Frequency range	87.9 — 107.9MHz
Sensitivity	11.2dBf (2 μ V, IHF '58)
50dB quieting Sensitivity	
MONO	18.3dBf (4.5 μ V, IHF '58)
STEREO	38.3dBf (45 μ V, IHF '58)
Total harmonic distortion	
MONO	0.2%
STEREO	0.3%
S/N	
MONO	75dB
STEREO	70dB
Frequency response	20Hz — 15 kHz (+1dB, -2dB)
Alternate channel selectivity	65dB
Capture ratio	1dB
Image rejection at 98MHz	44dB
IF rejection at 98MHz	80dB
Spurious response rejection at 98MHz	75dB
AM suppression	50dB
Stereo separation	
1 kHz	40dB
10kHz	30dB
Carrier leak	
19kHz	-35dB
38kHz	-50dB
Antenna terminal(s)	75 Ω (unbalanced)

AM Tuner Section

Frequency range	530 — 1710kHz
Sensitivity	20 μ V, 330 μ V/m
Selectivity	55dB
Image rejection at 1000kHz	40 dB
IF rejection at 1000kHz	60dB

Video Section

Output voltage at 1 V input (unbalanced)	1 \pm 0.1 Vp-p
Maximum input voltage	1.5 Vp-p
Input/output impedance	75 Ω

Amplifier Section

Rated minimum sine wave RMS power output	
20 Hz–20 kHz both channels driven	
0.05% total harmonic distortion	120W per channel (8 Ω)
1 kHz continuous power output, both channels driven 0.05% total harmonic distortion	125W per channel (8 Ω)
Total harmonic distortion	
Rated power at 20 Hz – 20kHz	0.05% (8 Ω)
Half power at 1 kHz	0.03% (8 Ω)
Power output at the Dolby Pro Logic operation	
0.9% at 1 kHz,	
Front	2X100 W (8 Ω)
Center	100 W (8 Ω)
Surround	100 W (8 Ω)
Sub-Woofer	100 W (8 Ω)
Low frequency damping factor	30 (8 Ω)
Load impedance	
A or B	4-8 Ω
A and B	8 Ω
Center	8 Ω
Surround	4-8 Ω
Sub-Woofer	8 Ω
Dynamic headroom	2dB (8 Ω)
SMPTE intermodulation distortion	0.3% (8 Ω)
Frequency response	
PHONO	RIAA standard curve \pm 0.8dB
CD, TAPE, VCR 1, TV, VCR 2, VDP	7Hz – 70kHz, \pm 3dB
Input sensitivity	
PHONO	0.4mV (3mV, IHF '66)
CD, TAPE, VCR 1, TV, VCR 2, VDP	27mV (200mV, IHF '66)
S/N (IHF A)	
PHONO	70dB (80dB, IHF '66)
CD, TAPE, VCR 1, TV, VCR 2, VDP	75dB (85dB, IHF '66)
Input impedance	
PHONO	47k Ω
CD, TAPE, VCR 1, TV, VCR 2, VDP	22k Ω
Tone controls	
BASS	50Hz, +10 to -10dB
TREBLE	20kHz, +10 to -10dB
Loudness control (volume at -30dB)	50Hz, +9dB
Sub-Woofer frequency response	7-100Hz

⚠ WARNING

This service information is designed for experienced repair technicians only and is not designed for use by the general public. It does not contain warnings or cautions to advise non-technical individuals of potential dangers in attempting to service a product. Products powered by electricity should be serviced or repaired only by experienced professional technicians. Any attempt to service or repair the product or products dealt with in this service information by anyone else could result in serious injury or death.

■ General

Power consumption 265W, 335VA (In standby condition : 2W)
Power supply AC 120V, 60Hz
Dimensions (W x H x D) 430 x 158 x 358 mm
 (16^{15/16}" x 6^{7/32}" x 14^{3/32}")
Weight 10.3 kg (22.7 lb.)

Notes :

1. Specifications are subject to change without notice. Weight and dimensions are approximate.
2. Total harmonic distortion is measured by the digital spectrum analyzer.

■ Contents

	PAGE		PAGE
• SAFETY PRECAUTION.....	2	• TERMINAL GUIDE OF ICs, TRANSISTORS & DIODES..	17 ~ 18
• BEFORE REPAIR AND ADJUSTMENT.....	2	• SCHEMATIC DIAGRAM.....	18 ~ 35
• PROTECTION CIRCUITRY.....	2	• PRINTED CIRCUIT BOARD.....	36 ~ 43
• OPERATION CHECKS AND MAIN COMPONENT REPLACEMENT	3 ~ 7	• CABINET PARTS LOCATION.....	44
• FAN MOTOR TROUBLESHOOTING.....	8	• REPLACEMENT PARTS LIST.....	45 ~ 47
• TROUBLESHOOTING.....	9 ~ 12	• RESISTORS & CAPACITORS.....	48 ~ 52
• BLOCK DIAGRAM.....	13 ~ 16	• PACKAGING.....	52
• TERMINAL FUNCTIONS OF ICs.....	17		

■ Safety Precaution (This "Safety Precaution" is applied only in U.S.A.)

1. Before servicing, unplug the power cord to prevent an electric shock .
2. When replacing parts ,use only manufacturer's recommended components for safety .
3. Check the condition of the power cord .Replace if wear or damage is evident .
4. After servicing ,be sure to restore the lead dress, insulation barriers ,insulation papers ,shields ,etc .
5. Before returning the serviced equipment to the customer, be sure to make the following insulation resistance test to prevent the customer from being exposed to a shock hazard .

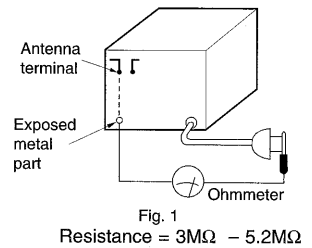

■ INSULATION RESISTANCE TEST

1. Unplug the power cord and short the two prongs of the plug with a jumper wire .
2. Turn on the power switch .
3. Measure the resistance value with ohmmeter between the jumper AC plug and each exposed metal cabinet part ,such as screwheads, antenna ,control shafts ,handle brackets , etc . Equipment with antenna terminals should read between 3MΩ and 5.2MΩ to all exposed parts* .(Fig. 1) Equipment without antenna terminals should read approximately infinity to all exposed parts . (Fig. 2)
 *Note :Some exposed parts may be isolated from the chassis by design. These will read infinity .
4. If the measurement is outside the specified limits ,there is a possibility of a shock hazard .The equipment should be repaired and rechecked before it is returned to the customer .

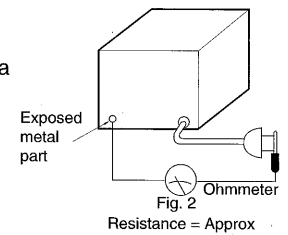

■ Before Repair and Adjustment

Disconnect AC power, discharge 4 Power Supply Capacitors C703, C704, C705 and C706 through a 10Ω , 5W resistor to ground. DO NOT SHORT-CIRCUIT DIRECTLY (with a screwdriver blade, for instance), as this may destroy solid state devices. After repairs are completed, restore power gradually using a variac, to avoid overcurrent.

Current consumption at AC 120 V, 60Hz in NO SIGNAL mode should be 500 ~ 1000 mA.

■ Protection Circuitry

The protection circuitry may have operated if either of the following conditions are noticed:

- No sound is heard when the power is turned on.
- Sound stops during a performance.

The function of this circuitry is to prevent circuitry damage if, for example, the positive and negative speaker connection wires are "shorted", or if speaker systems with an impedance less than the indicated rated impedance of the amplifier are used.

If this occurs, follow the procedure outlines below:

1. Turn off the power.
2. Determine the cause of the problem and correct it.
3. Turn on the power once again after one minute.

Note:

When the protection circuitry functions, the unit will not operate unless the power is first turned off and then on again.

■ Operation Checks and Main Component Replacement Procedures

"ATTENTION SERVICER" Some chassis components may have sharp edges. Be careful when disassembling and servicing.

1. This section describes procedures for checking the operation of the major printed circuit boards and replacing the main components.
2. For reassembly after operation checks or replacement, reverse the respective procedures. Special reassembly procedures are described only when required.
3. Select items from the following index when checks or replacement are required.

• Contents

• Checking Procedure For Each Major P.C.B.	page 3 ~ 5
• Main Component Replacement Procedures	5 ~ 7

■ Checking Procedure For Each Major P.C.B.

1. Checking of the Panel P.C.B., Pro Logic P.C.B. and Tuner P.C.B.

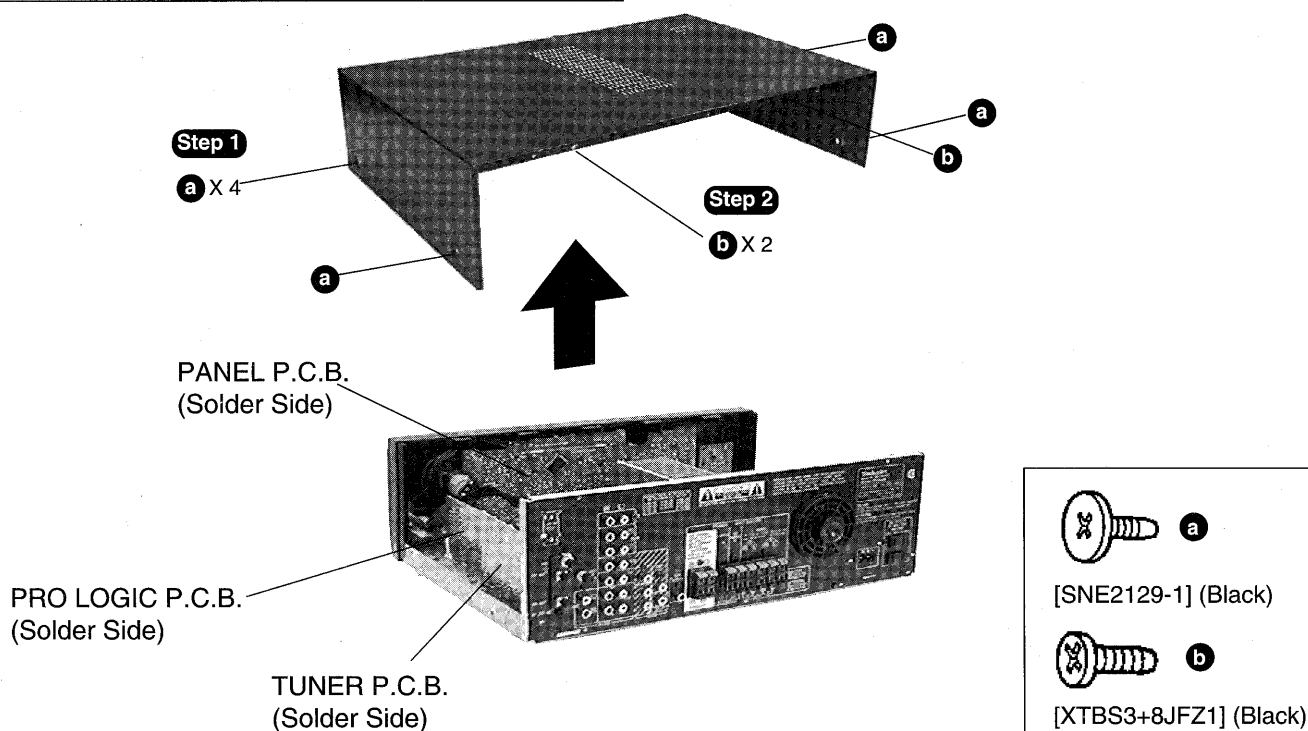

2. Checking of the In/Out terminal P.C.B.

- Step 1**
Remove the top cabinet.
- Step 3**
Release the catch, pull the rear panel in the direction of arrow ① and simultaneously remove the tuner P.C.B. in the direction of arrow ②.

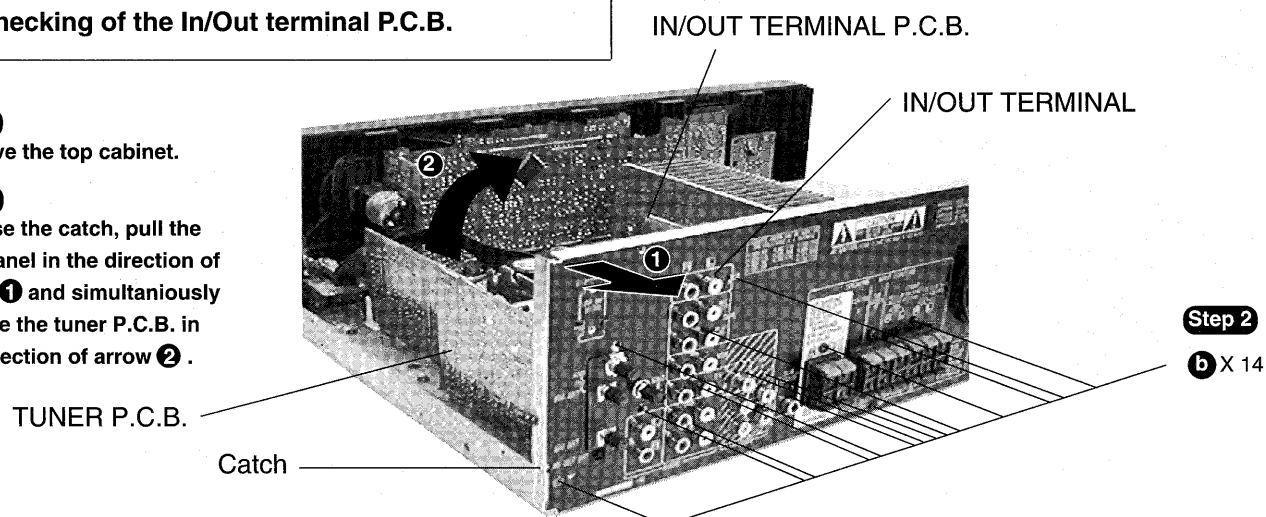

To Remove Front Panel, Panel P.C.B., Power Switch P.C.B. and Headphone Jack P.C.B.

Step 1

Remove the top cabinet.

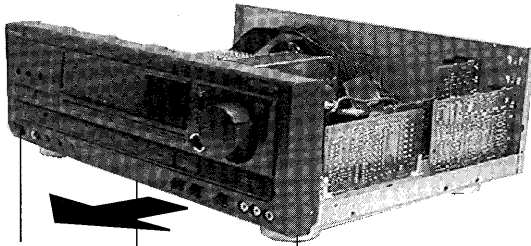

b X 3

Step 2

b

Step 3

Remove the front panel in the direction of arrow.

b

Power Switch P.C.B.

Headphone Jack P.C.B.

Step 4

Remove the Sub-Woofer lever knob, Volume Knob and Nut.

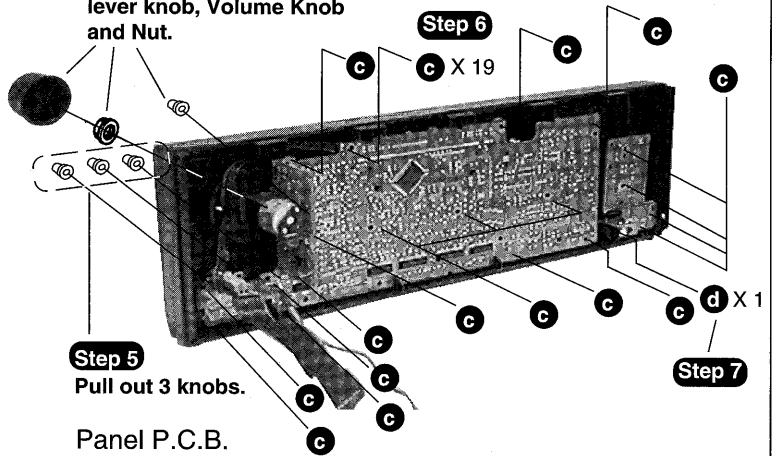

Step 5

Pull out 3 knobs.

Panel P.C.B.

Step 7

Step 8

Pull out the Headphone Jack P.C.B.



c

[XTBS26+10J]



d

[RHD26016]

3. Checking of the Main P.C.B.

Step 1

Remove the top cabinet.

Step 2

Remove the front panel.

Step 4

e X 7

Step 3

f X 9

Step 7

Lift the rear panel in the direction of arrow ② and remove the bottom chassis in the direction of arrow ③.

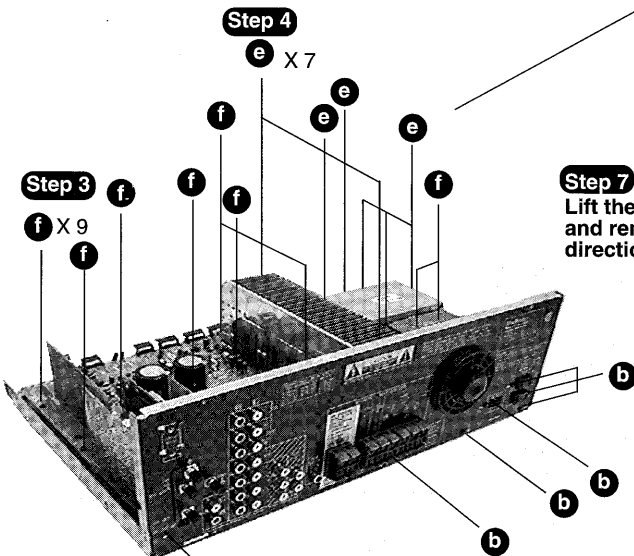
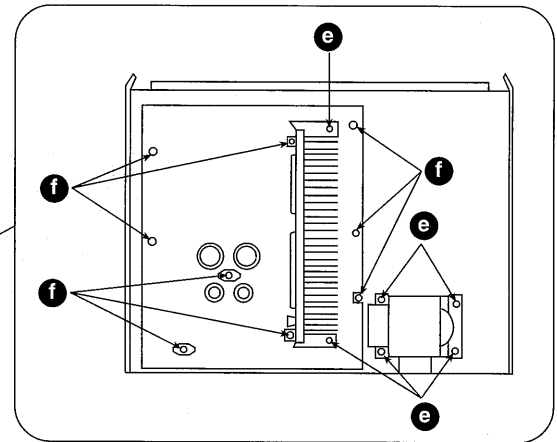

Step 5

b X 7

Step 6

Release 2 catches and pull the rear panel in the direction of arrow ① for about 10mm. (Note : All P.C.B. and a transformer are attach to the rear panel)

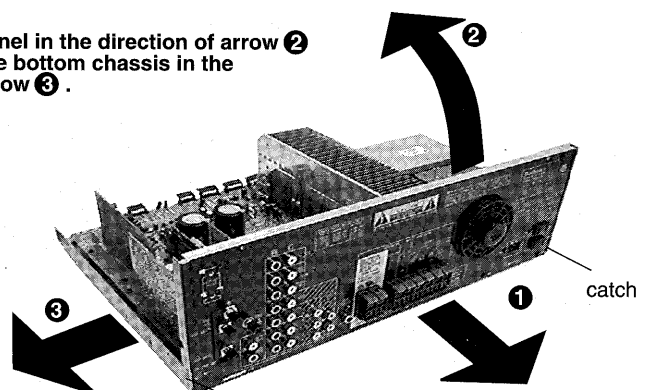

Step 8

Connect the front panel to the main P.C.B. as shown.

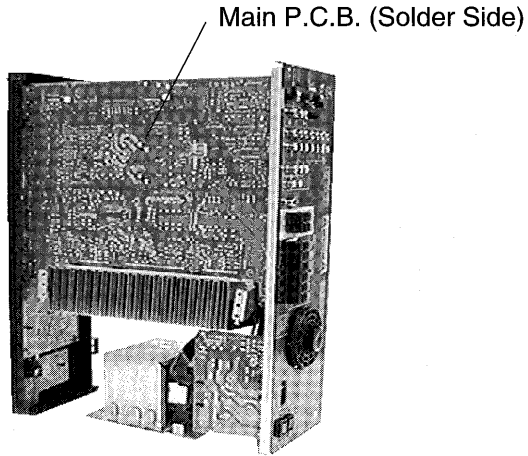

• Check the Main P.C.B. as shown on the right.



[XTB3+8FFZ] (Black)



[XTB3+20JFZ] (Black)

Main Component Replacement Procedures

1. Replacement of the Power IC and Regulator Transistor

Step 1

Remove the top cabinet.

Step 2 Cut the joints as shown below. (6 joints)

Locate the nipper to the thin portion of the joint.

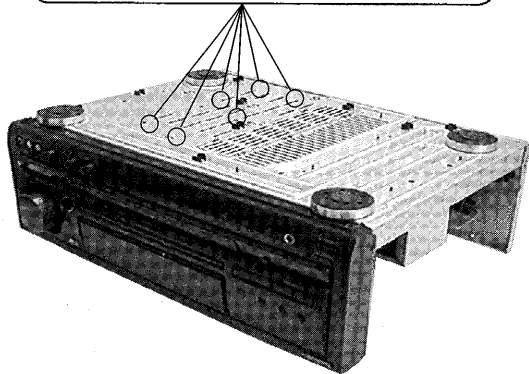
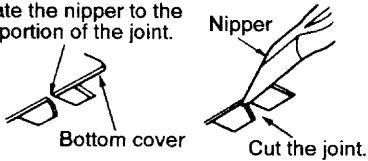

Step 3 Fold the joints. (6 joints)

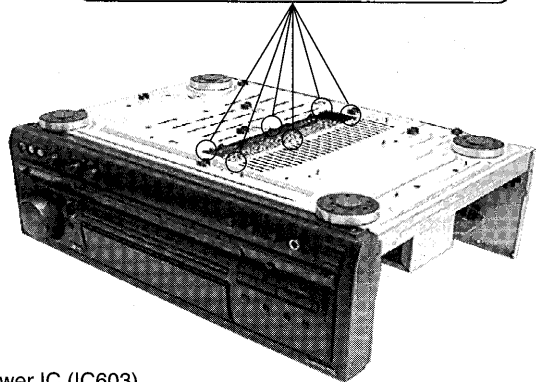
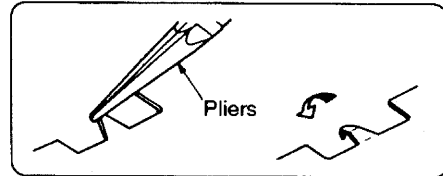

Power IC (IC603)
[RSN33M5-P]

Power IC (IC602)
[RSN36S5-P]

Power IC (IC601)
[RSN36S5-P]

Step 4

Desolder the terminals of Power IC and Regulator Transistor.

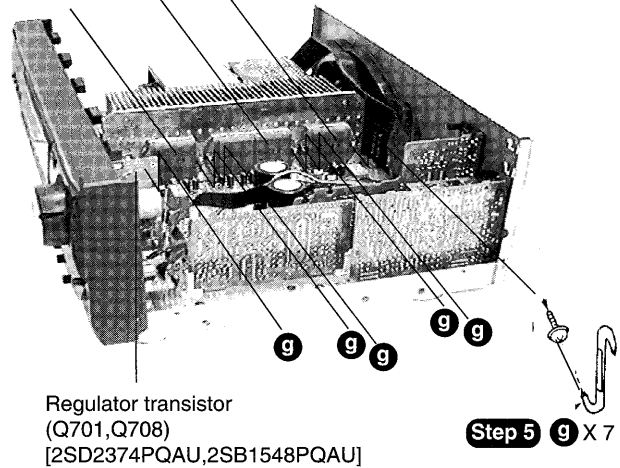
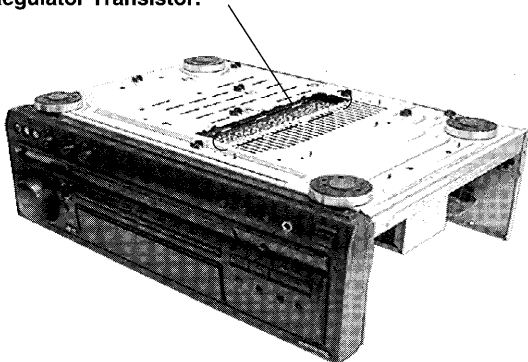

Regulator transistor
(Q701, Q708)
[2SD2374PQAU, 2SB1548PQAU]

Step 5 g X 7

Installation of the bottom cover after replacement

Step 1

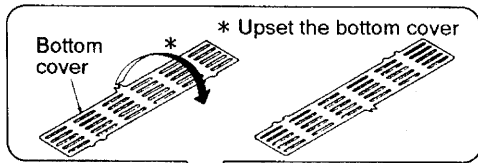

Step 3

Screw (XTB3+8J)
(Prepare this screw to fix the bottom cover.)

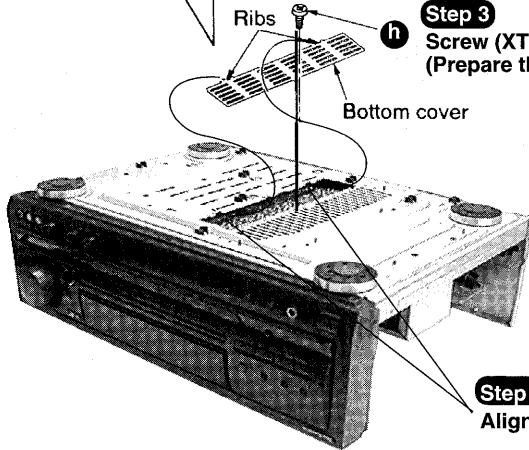

Step 2

Align the ribs of bottom cover with lugs.



[XTW3+15T]

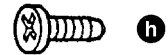

[XTB3+8J] (Black)

CAUTION

1. After replacing the power IC or regulator transistor, apply a sufficient quantity of compound grease (RFKX0002/SZZ0L15) between the heat sink and the power IC or regulator transistor (Radiation of power IC).
2. Tighten enough the screws (g) after replacing the power IC and regulator transistor. Otherwise, the heat radiation works little.
3. When installing or removing the power IC or transistor holder, be sure to use an offset screwdriver.

- A long straight screwdriver cannot be used for removing or mounting the screws since its long grip interferes with the neighbouring P.C.B. (See Fig.1)
- A short straight screwdriver may be used for removal, but cannot be used for mounting because the limited space in the unit will not allow sufficient tightening torque. (See Fig.2)

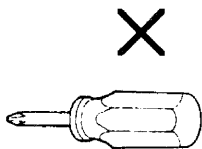

A short straight screwdriver

Fig.2

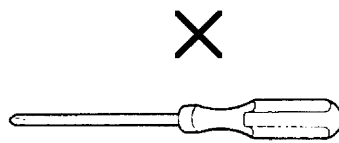

A long straight screwdriver

Fig.1

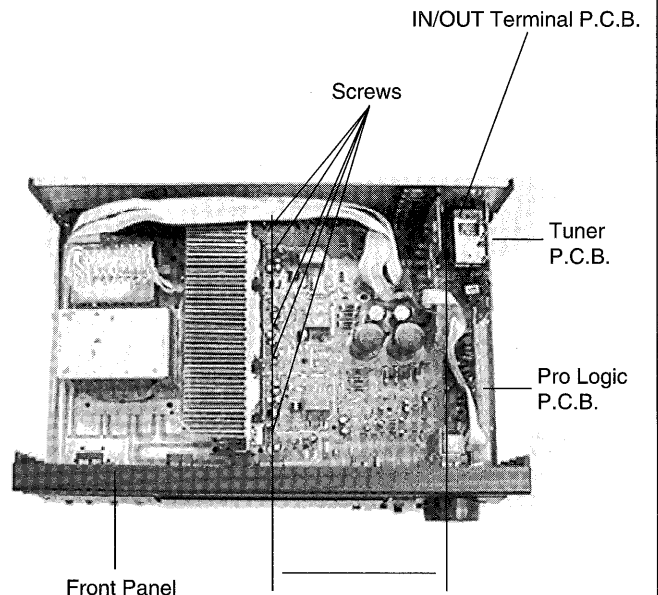

About 15cm
(A long straight screwdriver cannot be used)

Fig.1

- Insufficient tightening will cause poor heat dissipation from the power IC and regulator transistor and, in the worst case, may lead to their thermal breakdown.

—OFFSET SCREWDRIVER—

•The PROTO offset screwdriver No.34-1/4 is recommended for use in the application above.

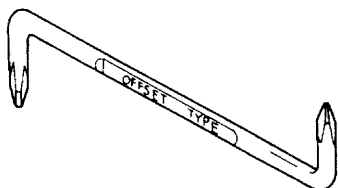

No.		
34 1/4	1 & 2	4 3/4"

•The address of PROTO International Sales is as follows.



International Sales

International Sales Office
Stanley-Proto Industrial Tools
14117 Industrial Park Blvd.
Covington, GA 30209 U.S.A.
Fax: 706-786-4387
Phone: 706-787-3800

Australia, New Zealand &
South Pacific
Stanley-Proto Industrial Tools
P.O.Box 10
400 Whitehorse Road
Nunweding 3131
Victoria, Australia
Fax: 61-3-894-1173
Phone: 61-3-878-9244

Singapore, Indonesia,
Philippines, Korea, Hong
Kong, Malaysia, China.
Stanley-Proto Asia Pacific
12 Gul Drive
Singapore 2262
Fax: 65-861-3206
Phone: 65-862-0883

Thailand
Stanley-Proto Thailand Ltd.
1017 Moo 13 Bangkaew
Amphur Bangplee
Samutprakarn, Thailand
Fax: 66-2-316-6071
Phone: 66-2-316-8655

Japan
Stanley Works Japan
2-7-16 Hyakunin-Cho
Shinjuku-ku
Tokyo 160 Japan
Fax: 81-3-3360-8456
Phone: 81-3-3360-8458

Mexico
Herramientas Stanley S.A.
DE C.V.
Apartado Postal 675
72030 Puebla, Pue, Mexico
Fax: 52-22-494-4880
Phone: 52-22-495-300

South & Central America,
Puerto Rico, The Caribbean
Stanley Inter-America
2101 N.W. 84th Ave.
Miami, Florida 33122
Fax: 305-594-4261
Phone: 305-591-3828

Europe
Stanley-Proto Europe
Woodside, Sheffield
539PD
England
Fax: 44-742-739-038
Phone: 44-742-768-888

Canada
Stanley-Proto Canada
1100 Corporate Drive
Burlington, Ontario
Canada, L7L 5R6
Fax: 416-335-0075
Phone: 416-335-0075

Middel East, Mediterranean
& Africa
Stanley-MEMA
Cory House The Ring
Bracknell Berkshire
RG 12 1A2
England
Fax: 44-344-485-526
Phone: 44-344-51813

2. Replacement of the fan motor

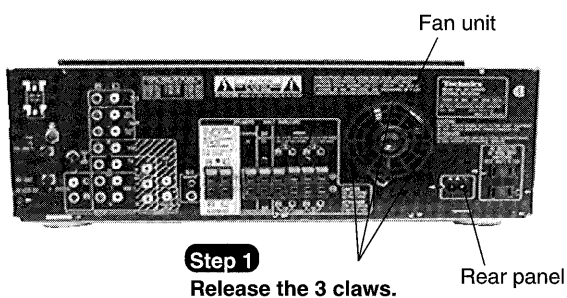

NOTE

When replacing the fan motor, align the boss of the fan case with the hole of the fan motor.

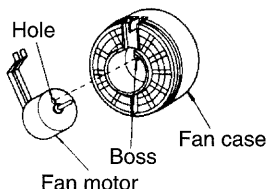

Step 2
Put a screwdriver at the root of the fan and remove it.

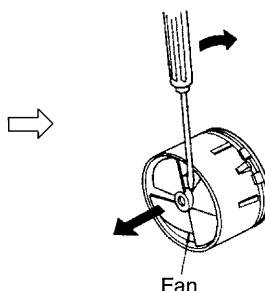

Step 3
Remove the fan cap.

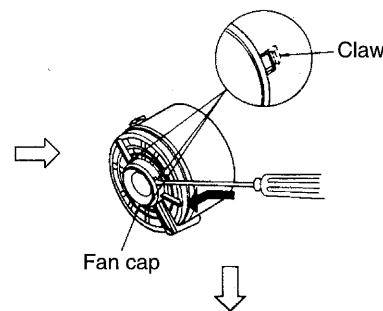

Step 4
Desolder the wires from the motor terminal and replace it with a new one.

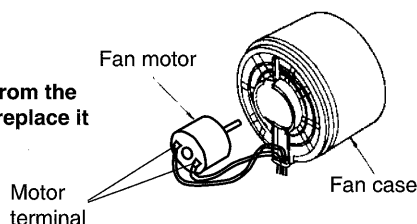

Fan Motor Troubleshooting

The Model SA-EX900 employ fan motor error sensing electronics.

If the cooling fan is not operating and "OVER LOAD" is displayed on the FL display, check the fan motor and its driving circuit.

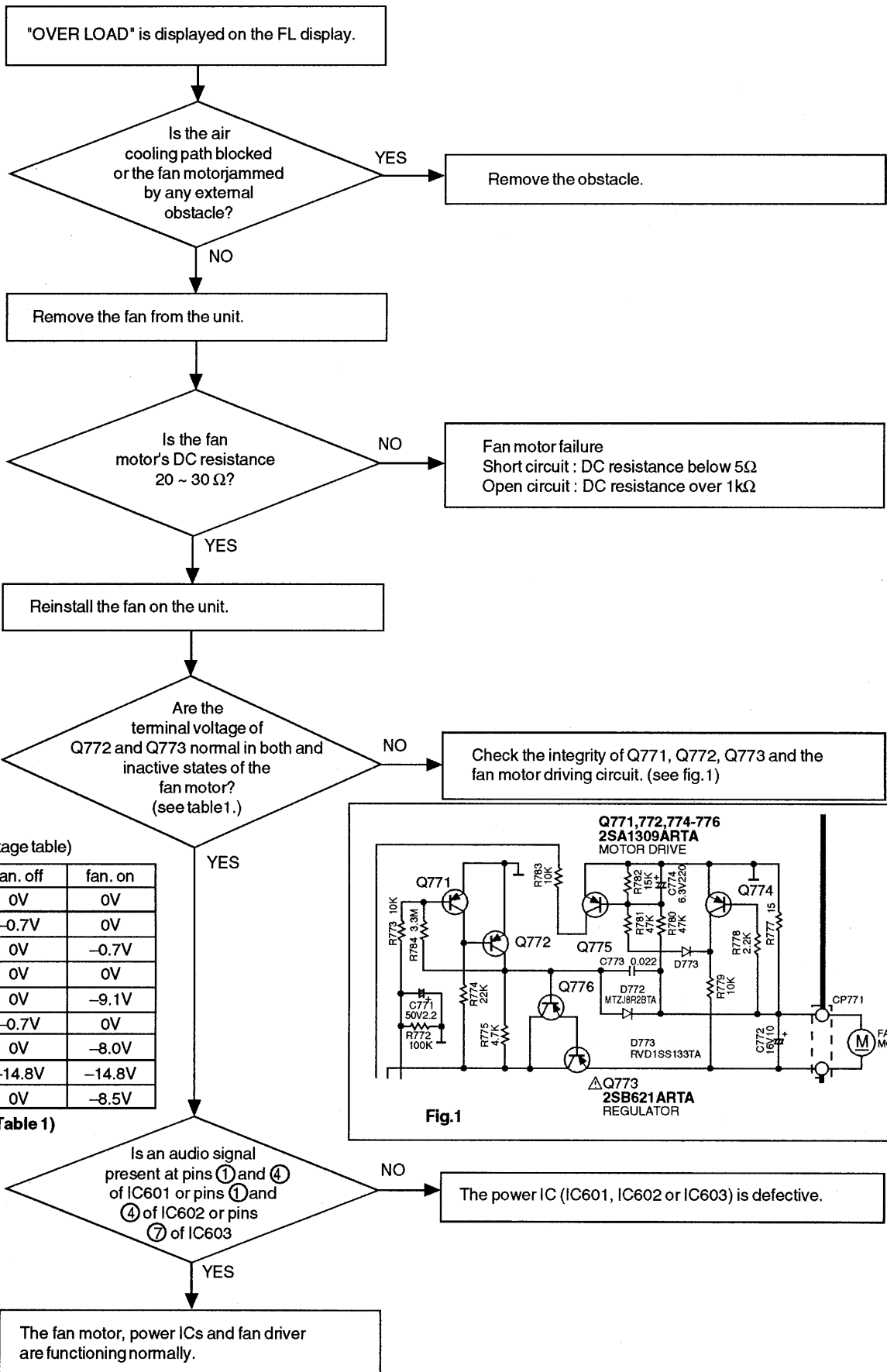

Troubleshooting

This unit has test points on each circuit board block for use in troubleshooting.

CONNECTION

Connect either a CD player, tape deck or AF oscillator to the input terminals of the unit.

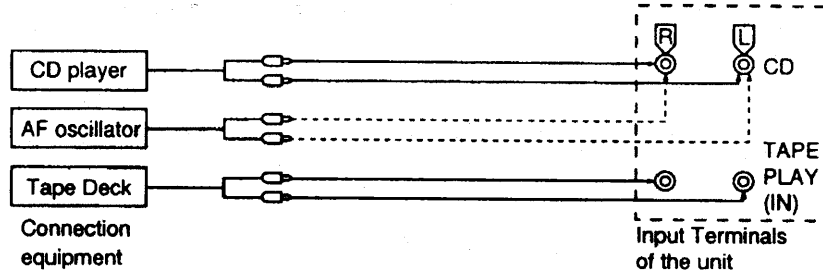

REQUIRED ITEMS

1. Testing with a CD player ——— Test disc (SZZP1054C / first program, 1kHz, 0dB)
2. Testing with a tape deck ——— Test tape (QZZCLA / 315Hz, 0dB)
3. Testing with a AF oscillator ——— Set the output at 500Hz, 200mV
4. Oscilloscope (min. 10MHz) - - - - - To measure the output waveform at the test points.



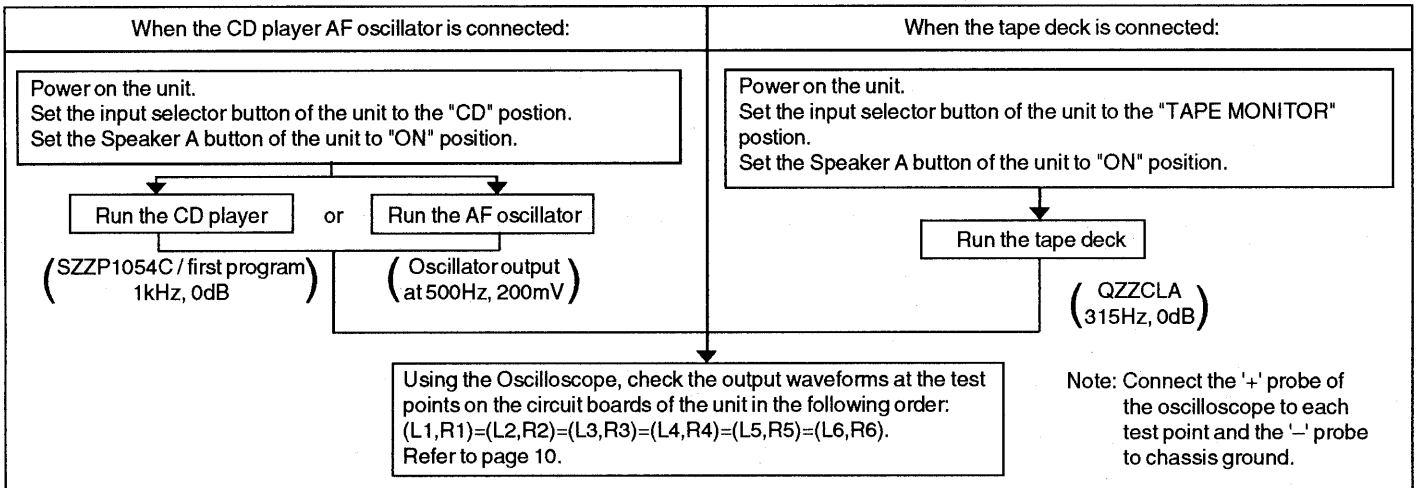



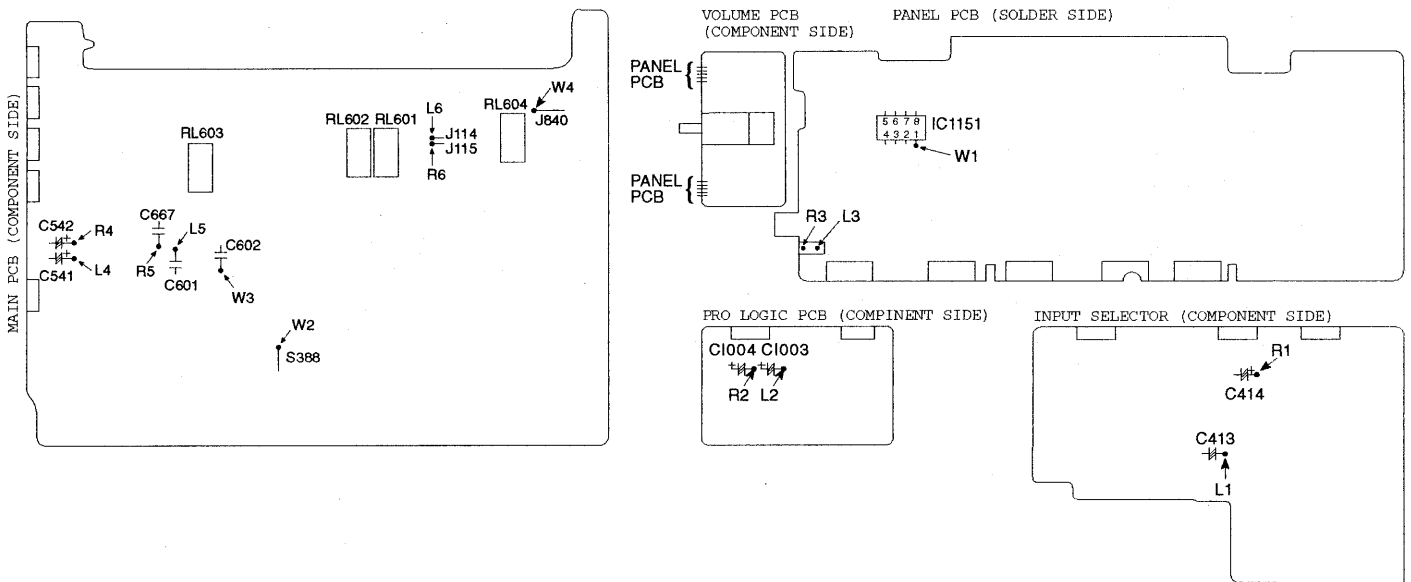

TEST PROCEDURE FOR AMPLIFIER CIRCUIT

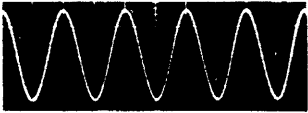
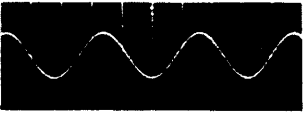
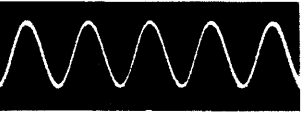
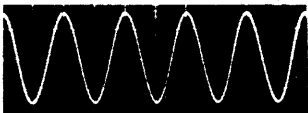
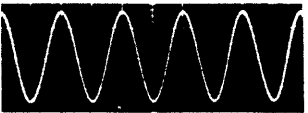
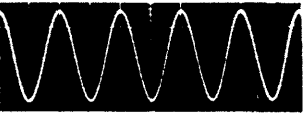
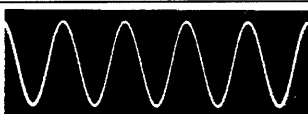
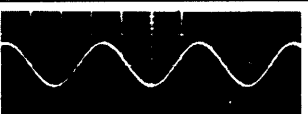
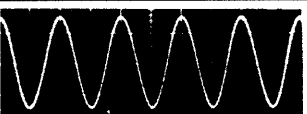
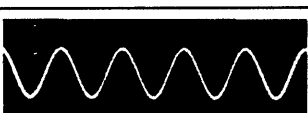
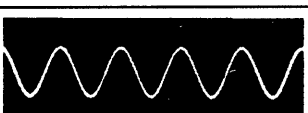
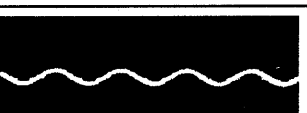
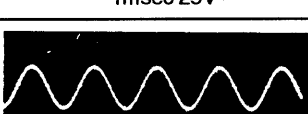

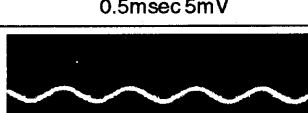
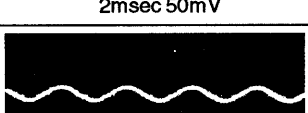
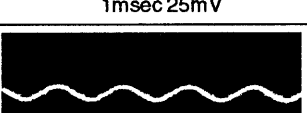
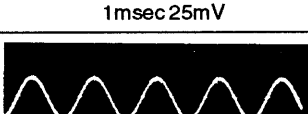
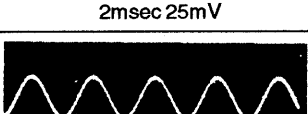
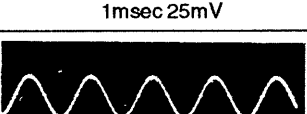

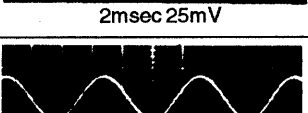
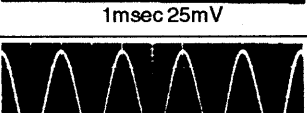
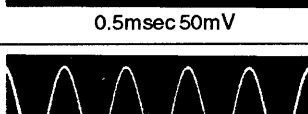
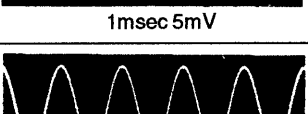
TEST POINTS POSITIONS OF AMPLIFIER CIRCUIT

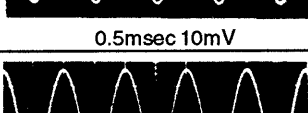

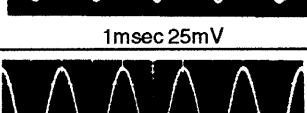
NORMAL WAVEFORMS OF AMPLIFIER CIRCUIT AND LIKELY FAULTY BLOCKS

TP	CD player	Tape deck	AF oscillator	Likely faulty block if the normal waveform shown at the left is not present.
L1/R1	 0.5msec 0.2V	 1msec 50mV	 1msec 20mV	Input selector block IC401 & area
W1	 0.5msec 0.1V	 1msec 20mV	 1msec 20mV	Sub-Woofer amplifier & area
L2/R2	 0.5msec 0.2V	 1msec 50mV	 1msec 20mV	Dolby pro logic block IC1001 and IC1002 & area
W2	 1msec 25V	 1msec 25mV	 1msec 25mV	Sub-Woofer lever block VR1150 & area
L3/R3	 0.5msec 5mV	 2msec 50mV	 1msec 25mV	Master volume block VR501 & area
W3	 1msec 25mV	 2msec 25mV	 1msec 25mV	Power limiter block Q575, Q576 & area
L4/R4	 0.5msec 5mV	 2msec 25mV	 1msec 25mV	Tone control block IC511 & area
W4	 0.5msec 50mV	 1msec 5mV	 1msec 25mV	Main amplifier block IC601 & area
L5/R5	 0.5msec 10mV	 1msec 50mV	 1msec 25mV	Power limiter block Q581 to Q584 & area
L6/R6	 0.5msec 0.2mV	 2msec 50mV	 1msec 50V	Main amplifier block IC601, 16603 & area

Measurement conditions. Sub-Woofer Control (VR1150) Volume control (VR501), Treble control (VR512) and Bass control (VR511) positions :  
 *Volume control position (VR501) for these test

CHECKING PROCEDURE FOR SURROUND CIRCUIT

Outputting surround signal normally requires that opposite phase signals be applied to both the left and right channels. However, this unit incorporates a service mode, allowing the surround circuit to be tested using in-phase signals.

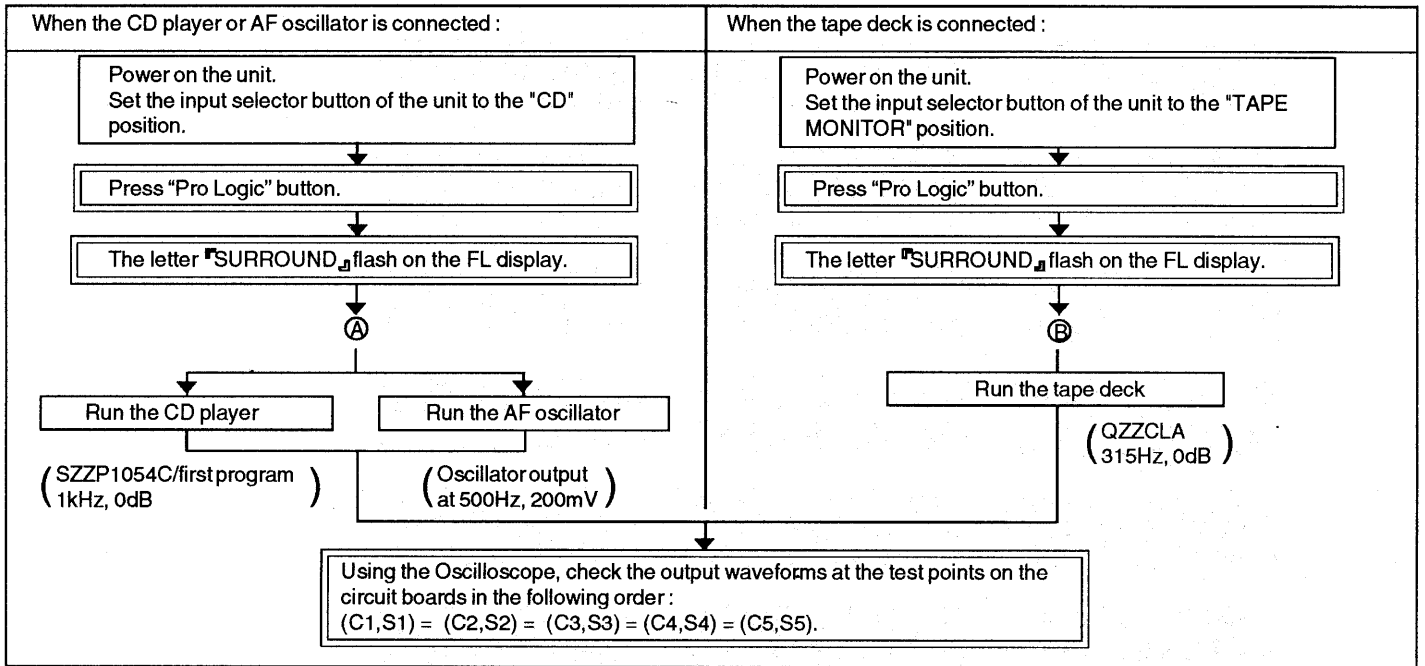

• To exit the service mode, power off the unit.

TEST POINTS POSITIONS OF SOURROUND CIRCUIT

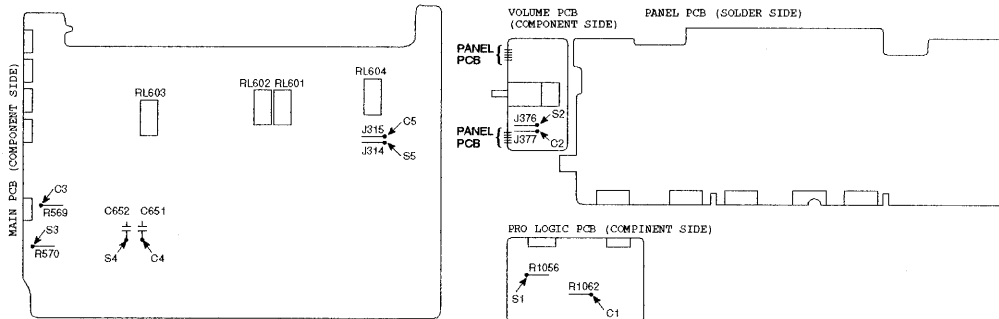

NORMAL WAVEFORMS OF AMPLIFIER CIRCUIT AND LIKELY FAULTY BLOCKS

TP	CD player	Tape deck	AF oscillator	Likely faulty block if the normal waveform shown at the left is not present.
C1				Dolby pro logic block IC1001 and IC1002 & area
	S1			
C2				Master volume block VR501 & area
	S2			

NORMAL WAVEFORMS OF AMPLIFIER CIRCUIT AND LIKELY FAULTY BLOCKS

TP	CD player	Tape deck	AF oscillator	Likely faulty block if the normal waveform shown at the left is not present.
C3	 0.5msec 10mV	 2msec 50V	 1msec 50V	Power limiter block Q571 to Q574 & area
S3	 2msec 25mV	 5msec 25mV	 4msec 25mV	
C4	 0.5msec 5V	 2msec 25V	 1msec 10V	Power limiter block Q571 to Q574 & area
S4	 2msec 25mV	 5msec 25mV	 5msec 25mV	
C5	 0.5msec 0.2mV	 2msec 20mV	 1msec 20mV	Main amplifier block IC602 & area
S5	 1msec 25mV	 2msec 25mV	 2msec 25mV	

Measurement conditions. Sub-Woofers Control (VR1511), Volume control (VR501), Tremble control (VR512) and Bass control (VR511) positions : ●
 *Volume control position (VR501) for these test : ●

CIRCUIT BLOCKS

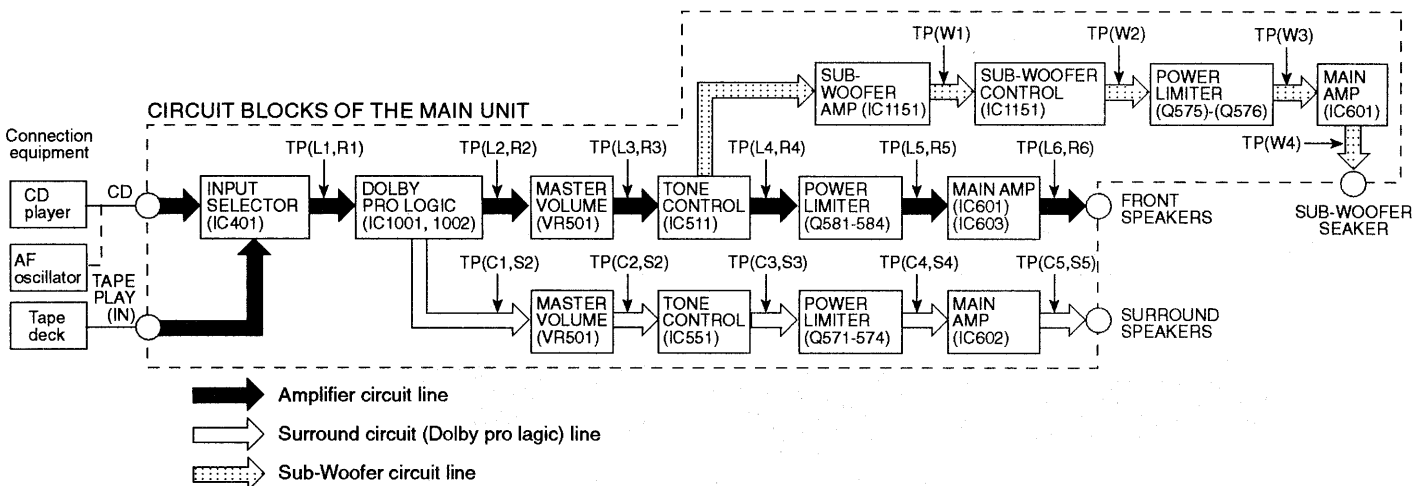

OVERLOAD DETECTION FUNCTION

The HIC protection circuit functions if any cord at a speaker terminal is short-circuited or if the unit overheats because of improper operation. At the same time, 'OVERLOAD' scrolls across the FL display.
 In this state, all keys remain in operative; if any key is pressed, 'SWITCH OFF POWER' scrolls across the FL display.
 If an overload occurs, immediately power off the unit and check the speaker connection, venting holes and cooling fans. After fixing any faults, power on the unit again and check for proper operation.
 If no defects are found, or if the unit remains overload after it is power on again, check the circuit for faults.

■ Block Diagram

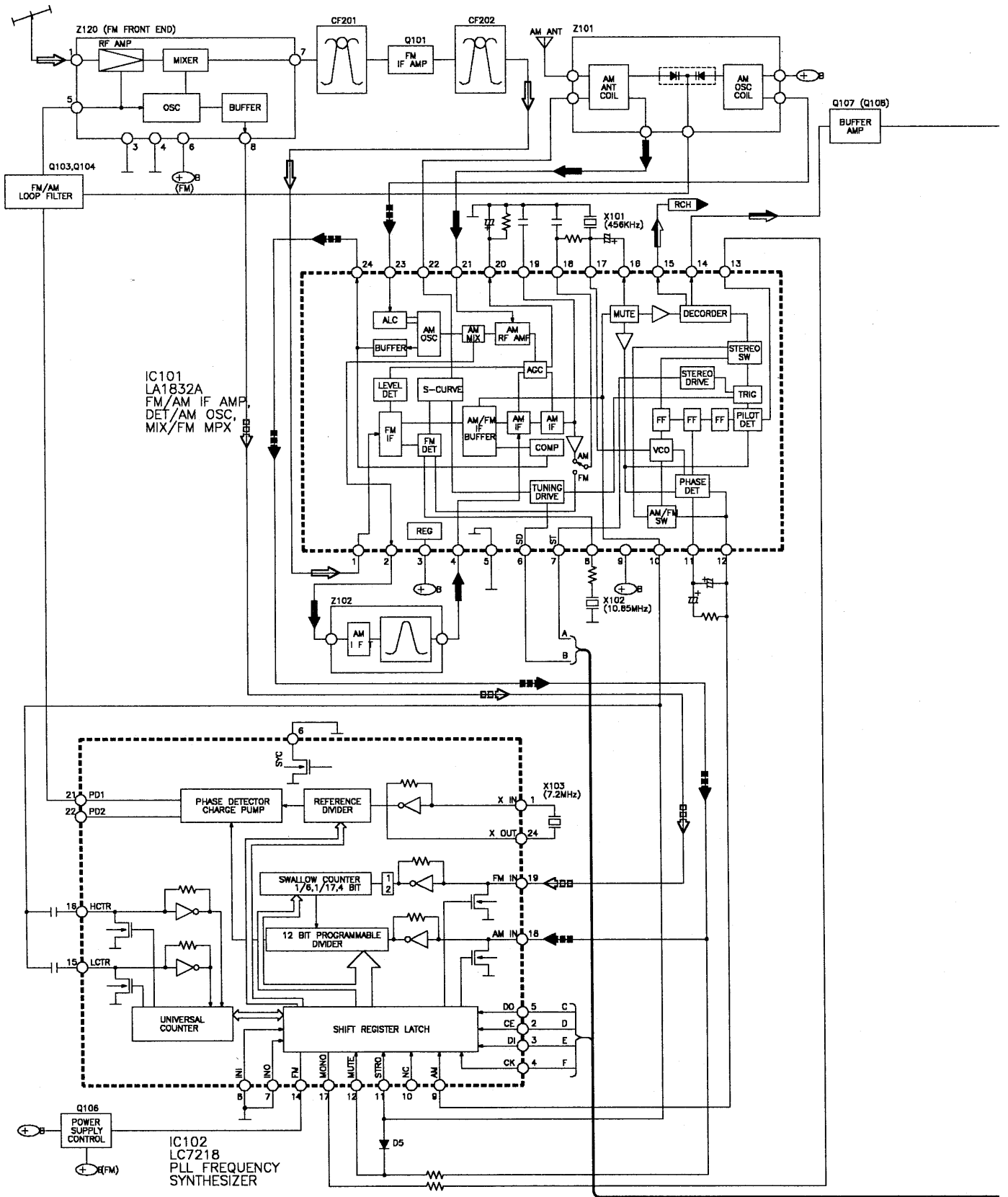

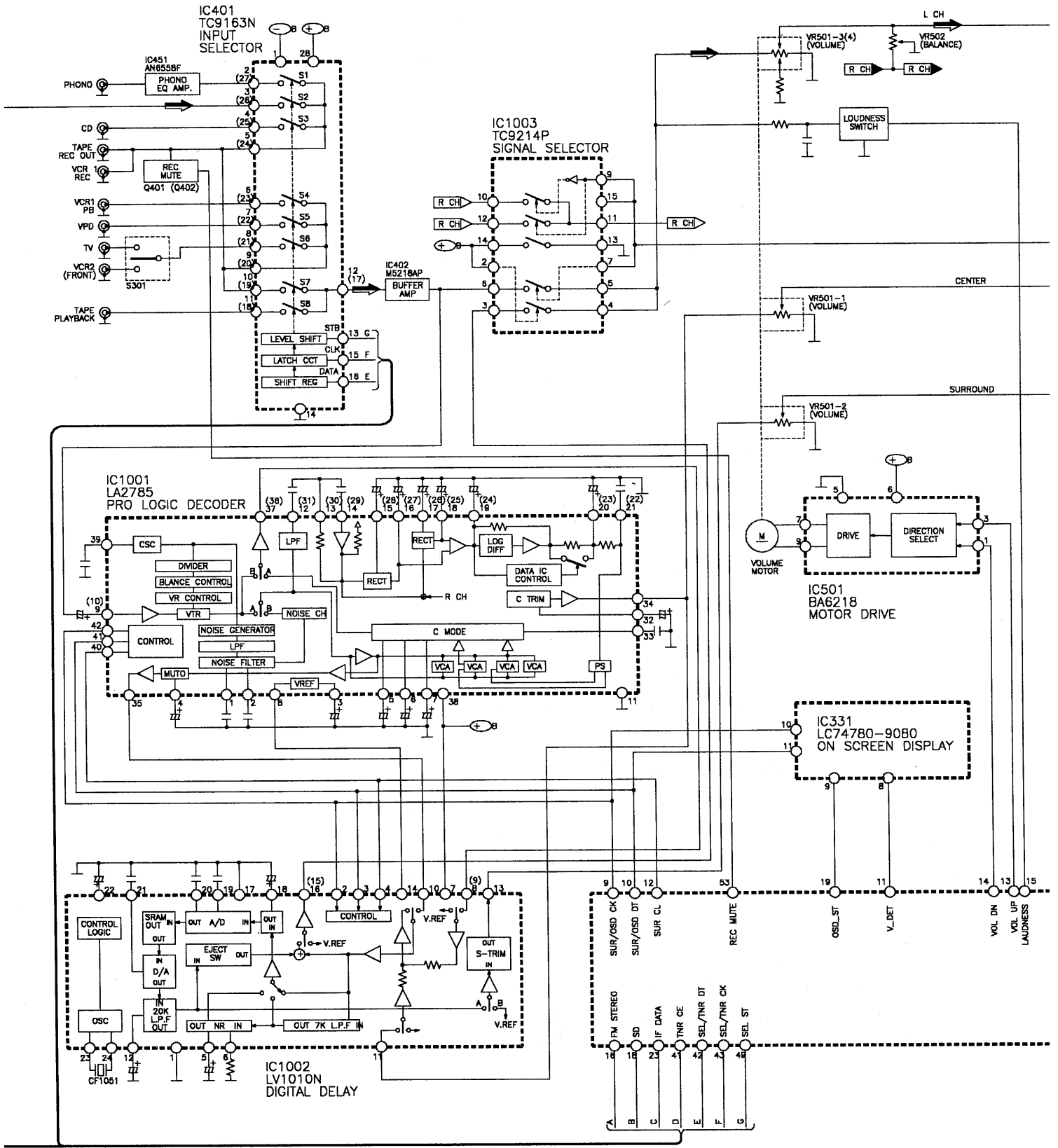

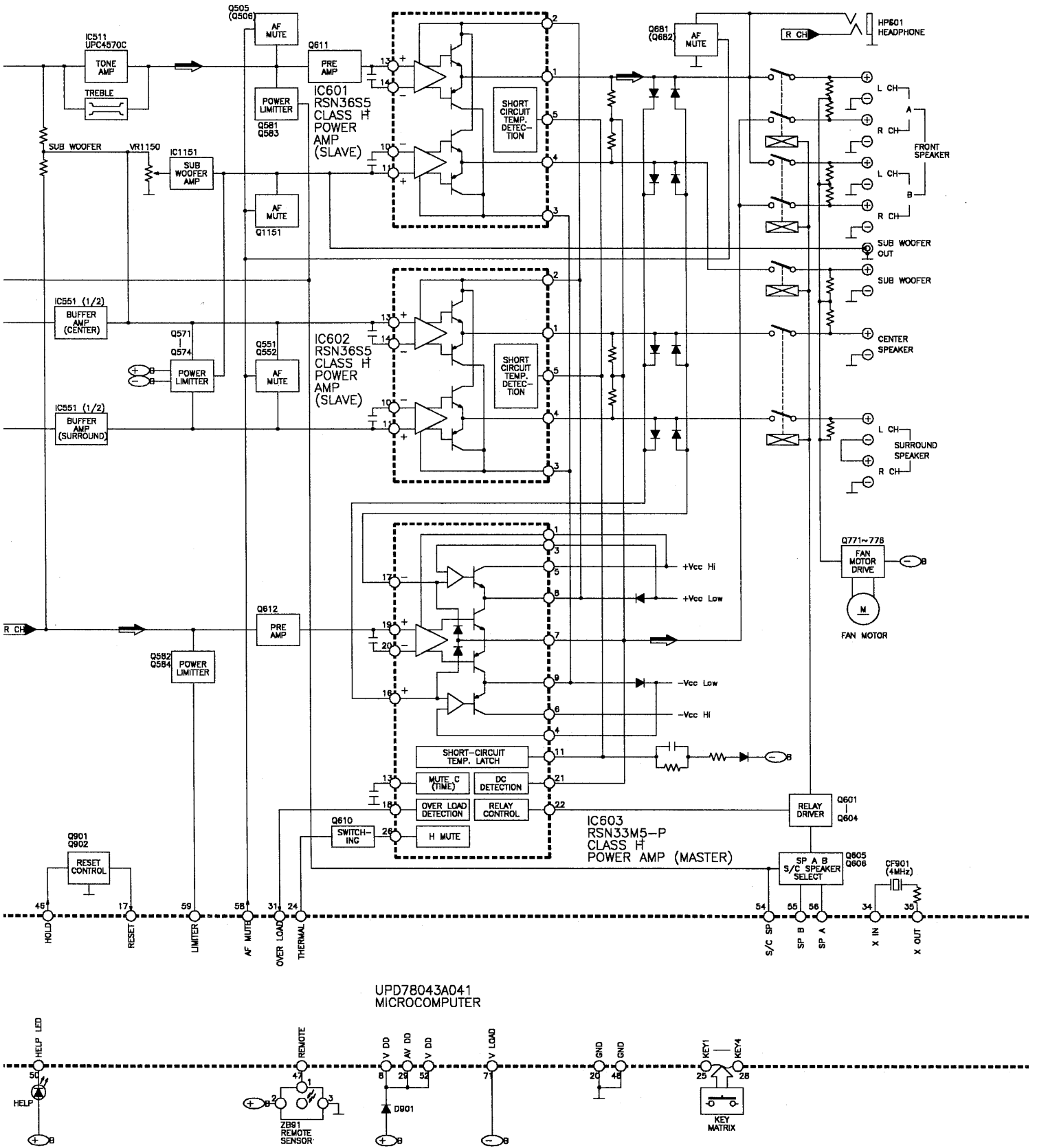

KEY

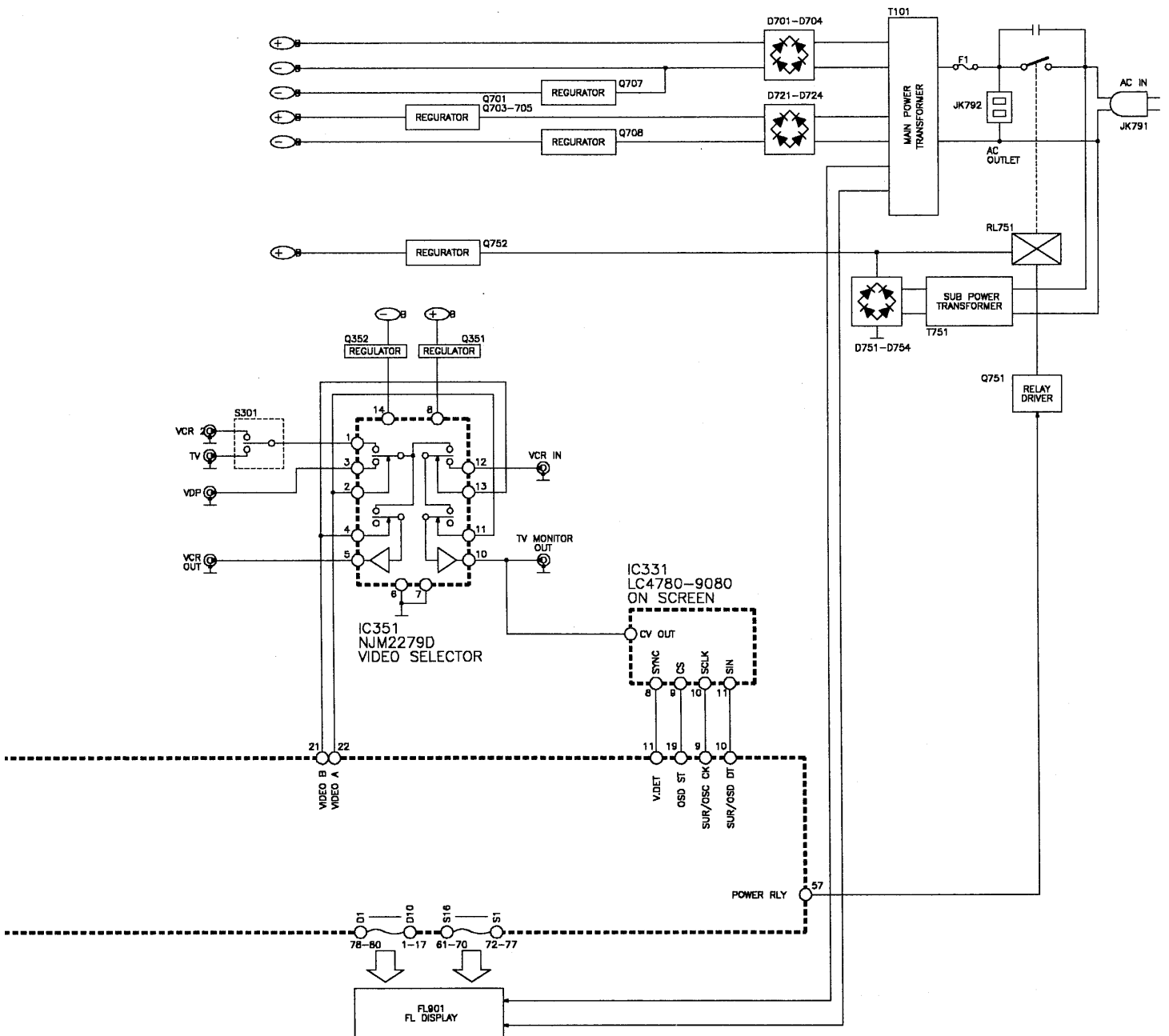
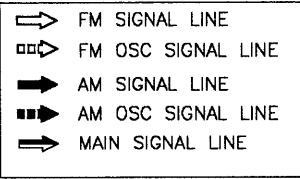



Terminal Functions Of ICs

• IC901 (UPD78043A041) System Microprocessor

Pin No.	Mark	I/O	Function
1~7	D4~D10	O	Digit signal of FL display
8	VDD	I	Power supply terminal
9	SUR/OSD_CK	O	Serial clock signal
10	SUR/OSD_DT	O	Serial data signal
11	VIDEO_DET	-	Not used
12	SUR_CE	O	Chip enable signal
13	VOL_UP	O	Rotate control terminal of
14	VOL_DWN	O	volume motor
15	LOUDNESS	-	Not used
16	FM_STEREO	I	Stereo signal detect terminal
17	RESET	I	Reset detect terminal
18	SD	I	Received signal detect terminal
19	OSD_ST	-	Not used
20	GND	-	GND terminal
21	VIDEO_B	O	Video selector control terminal
22	VIDEO_A	O	
23	IF_DATA	I	Serial data signal
24	THERMAL	O	Mute control terminal
25~28	KEY1~KEY4	I	Key matrix detect terminal
29	AVDD	I	Power supply terminal
30	AVREF	I	Power supply terminal
31	OVERLOAD	I	Over load detect terminal
32	XT2	-	Not used
33	GND	-	GND terminal
34	XIN	I	Crystal oscillator terminal
35	XOUT	O	(4MHz)

Pin No.	Mark	I/O	Function
36~40	SFC1~SFC5	-	Not used
41	TNR_CE	O	Chip enable signal
42	SEL/TNR_DT	O	Serial data signal
43	SEL/TNR_CK	O	Serial clock signal
44	TV/VCR2	-	Not used
45	ADAPTOR	-	Not used
46	HOLD	I	Hold signal input terminal
47	REMOTE	I	Remote control terminal
48	GND	-	GND terminal
49	SEL_ST	O	Level shift control terminal
50	HELP_LED	O	LED drive signal(HELP)
51	STANDBY_LED	-	Not used
52	VDD	I	Power supply terminal
53	REC_MUTE	-	Not used
54	S/C_SP	O	Surround and speaker select control terminal
55	SP_B	-	Not used
56	SP_A	O	Speaker select control terminal
57	POWER_RLY	O	Relay control terminal
58	AF_MUTE	O	Muting control terminal
59	LIMITTER	-	Not used
60	INIT_IN	-	Not used, connect to resistor
61~70	S16~S7	O	Segment signal of FL display
71	VLOAD	I	Power supply terminal
72~77	S6~S1	O	Segment signal of FL display
78~80	D1~D3	O	Digit signal of FL display

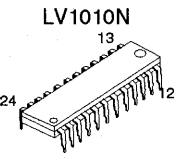
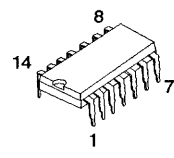
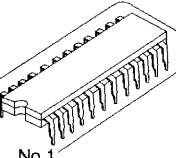
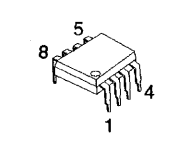
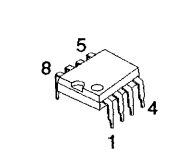
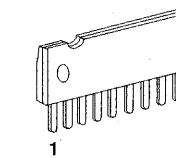
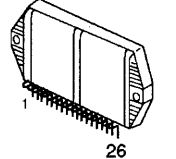
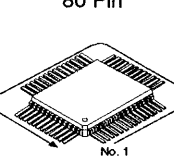
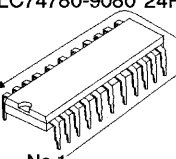
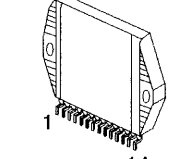
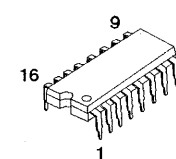
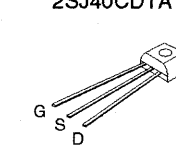
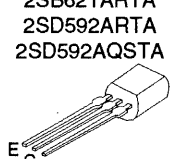
Terminal Guide of ICs, Transistors and Diodes

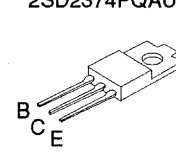
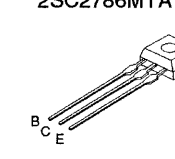
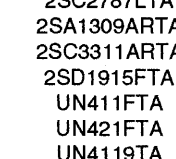
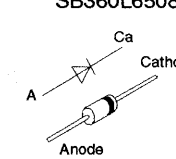
LA1832A LC7218 LV1010N 	NJM2279D 	TC9163N 28Pin 	M5218AP 	AN6558-F UPC4570C 	BA6218 
RSN3305-P 	UPD78043A041 80 Pin 	LA2785 42Pin LC74780-9080 24Pin 	RSN3655-P 	TC9214P 	2SK544F-AC 2SJ40CDTA 
2SC3940AQSTA 2SB621ARTA 2SD592ARTA 2SD592AQSTA 	RVTDTTC144YST 2SA933SSTA 2SK38ICTA RVTDTTC114EST 	2SB1548PQAU 2SD2374PQAU 	2SC2785FETA 2SC2786MTA 	2SC2787FL1TA 2SC2787LTA 2SA1309ARTA 2SC3311ARTA 2SD1915FTA UN411FTA UN421FTA UN4119TA 	1N5402BM21 SB360L6508 

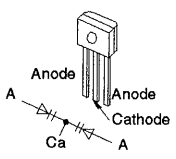
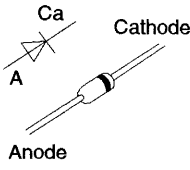
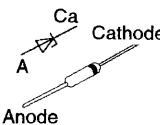
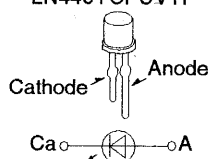
<p>SVC211SPA-AL</p> 		<p>RVD1SS133TA 1SR35200TB MA700ATA 1SS291TA MA167ATA</p>	<p>MTZJ10CTA MTZJ3R9ATA MTZJ4R7BTA</p> 	<p>MTZJ6R2BTA MTZJ6R8BTA MTZJ7R5CTA MTZJ5R1BTA MTZJ5R6BTA MTZJ3R0ATA MTZJ30DTA MTZJ15CTA MTZJ8R2BTA</p>	<p>LN41YCPHL LN440YCPUVTI</p> 
---	---	--	--	---	---

Schematic Diagram

(All schematic diagrams may be modified at any time with the development of new technology)

Note :

- | | | | | | |
|--------|---|---------------------------|---------------------|---|------------------------------------|
| • S301 | : | TV / VCR2 switch | • S970 | : | Simulated switch |
| • S946 | : | Power switch | • S971 | : | Theater switch |
| • S947 | : | Phono select switch | • S972 | : | Live switch |
| • S948 | : | Muting switch | • S973 | : | Club switch |
| • S950 | : | FM Auto/ Mono switch | • S974 | : | Hall switch |
| • S951 | : | Band select switch | • S975 | : | VDP switch |
| • S952 | : | Tuning decrease switch | • S976 | : | Delay time switch |
| • S953 | : | Tuning increase switch | • S980 | : | Speakers A switch |
| • S954 | : | Memory manual/auto switch | • S981 | : | Speakers B switch |
| • S956 | : | Preset decrease switch | • S982 | : | Loudness switch |
| • S957 | : | Preset increase switch | • S983 | : | Dolby Pro Logic/SFC off on switch |
| • S958 | : | Help switch | • S984 | : | Dolby Pro Logic mode select switch |
| • S960 | : | Tuner select switch | • S985 | : | Center mode select switch |
| • S961 | : | CD select switch | • VR501-1 ~ VR501-4 | : | Volume control |
| • S962 | : | Tape select switch | • VR502 | : | Balance control |
| • S963 | : | TV/VCR2 select switch | • VR511-1 ~ VR511-2 | : | Bass control |
| • S964 | : | VCR1 select switch | • VR512-1 ~ VR512-2 | : | Treble control |
| | | | • VR1150 | : | Sub-Woofers control |

Signal line

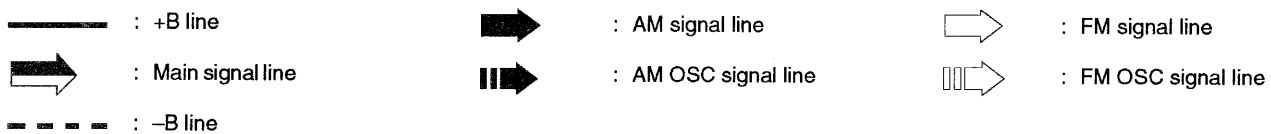

The voltage value and waveforms are the reference voltage of this unit measured by DC electronic voltmeter (high impedance) and oscilloscope on the basis of chassis.

Accordingly, there may arise some error in voltage values and waveforms depending upon the internal impedance of the tester or the measuring unit.

() AM

< > FM

Importance safety notice:

Components identified by Δ mark have special characteristics important for safety. Furthermore, special parts which have purposes of fire-retardant (resistors), high-quality sound (capacitors), low-noise (resistors), etc. are used. When replacing any of components, be sure to use only manufacturer's specified parts shown in the parts list.

Caution !

- IC, LSI and VLSI are sensitive to static electricity.
- Secondary trouble can be prevented by taking care during repair.
- Cover the parts boxes made of plastics with aluminium foil.
- Ground the soldering iron.
- Do not touch the pins of IC, LSI or VLSI with fingers directly.
- Put a conductive mat on the work table.

CAUTION : FOR CONTINUED PROTECTION AGAINST FIRE HAZARD, REPLACE ONLY WITH SAME TYPE F1, F3 & F4 8A 125V FUSE.



RISK OF FIRE-REPLACE FUSE AS MARKED.

FUSE CAUTION

 These symbols located near the fuse indicates that the fuse used is a fast operating type. For continued protection against fire hazard, replace with the same type fuse. For fuse rating, refer to the marking adjacent to the symbol.

 Ce symbole indique que le fusible utilisé est à rapide. Pour une protection permanente, n'utiliser que des fusibles de même type. Ce dernier est indiqué là où le présent symbole est apposé.

B PANEL CIRCUIT

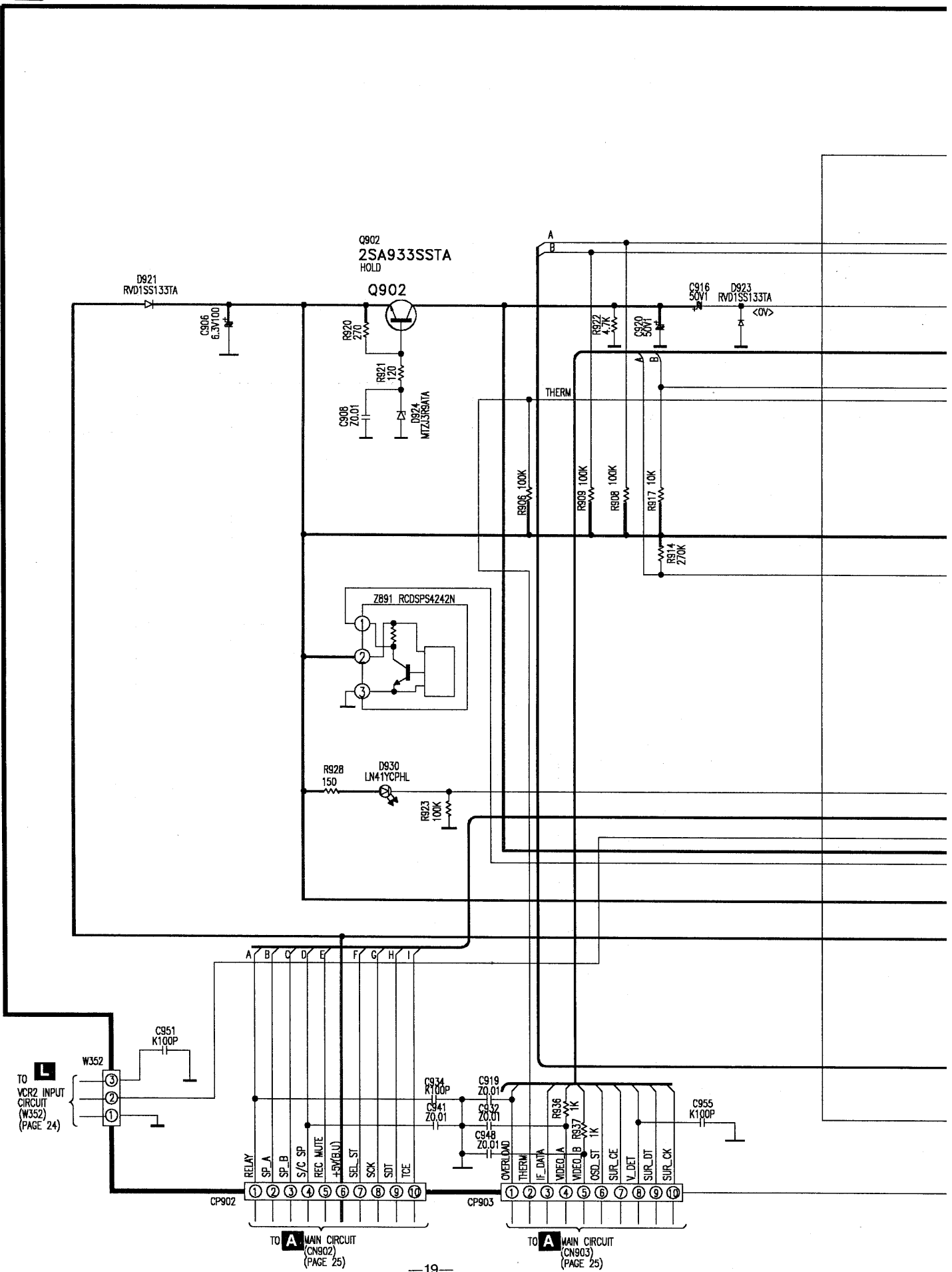

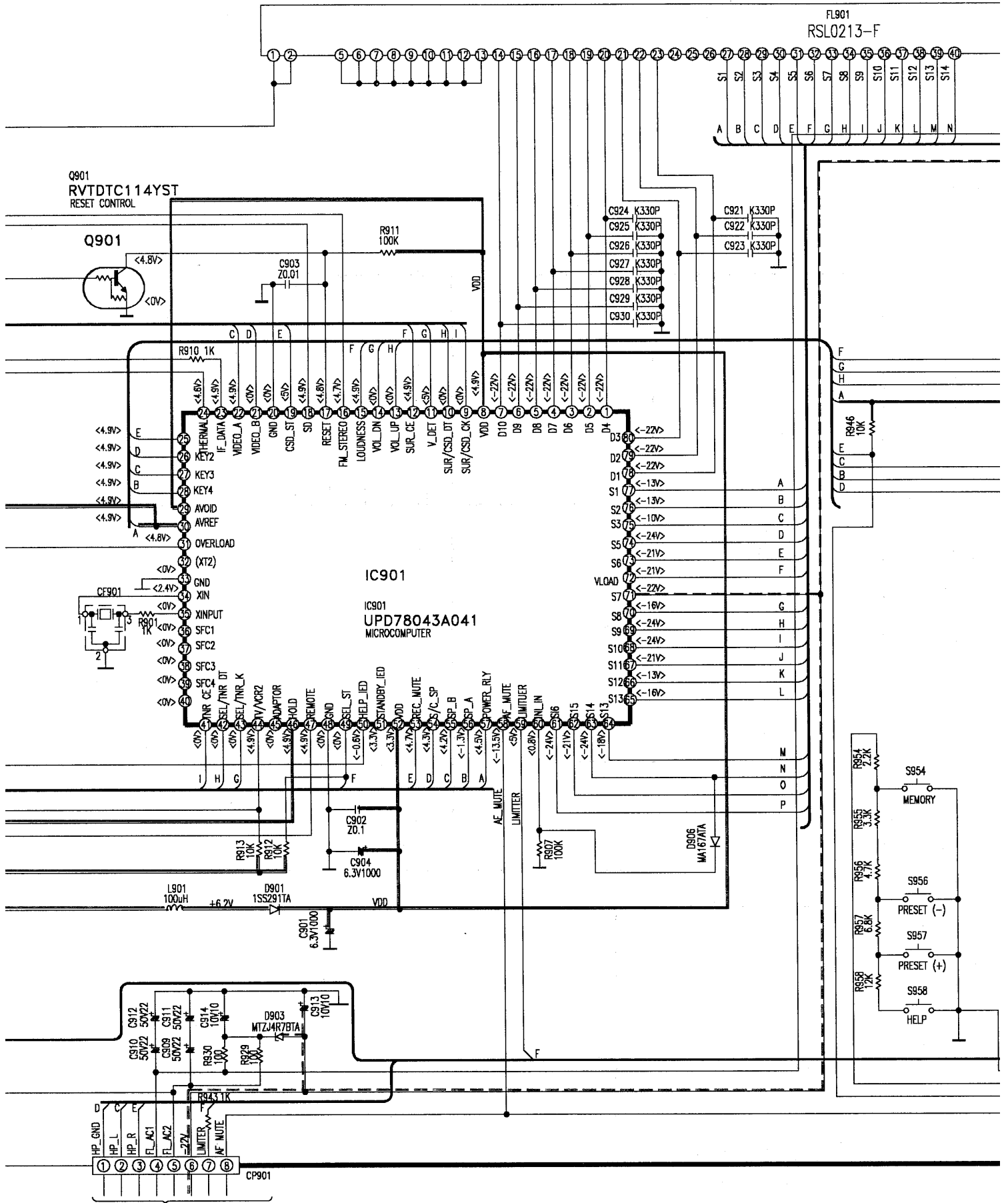

TO **A** MAIN CIRCUIT (CN901) (PAGE 25)

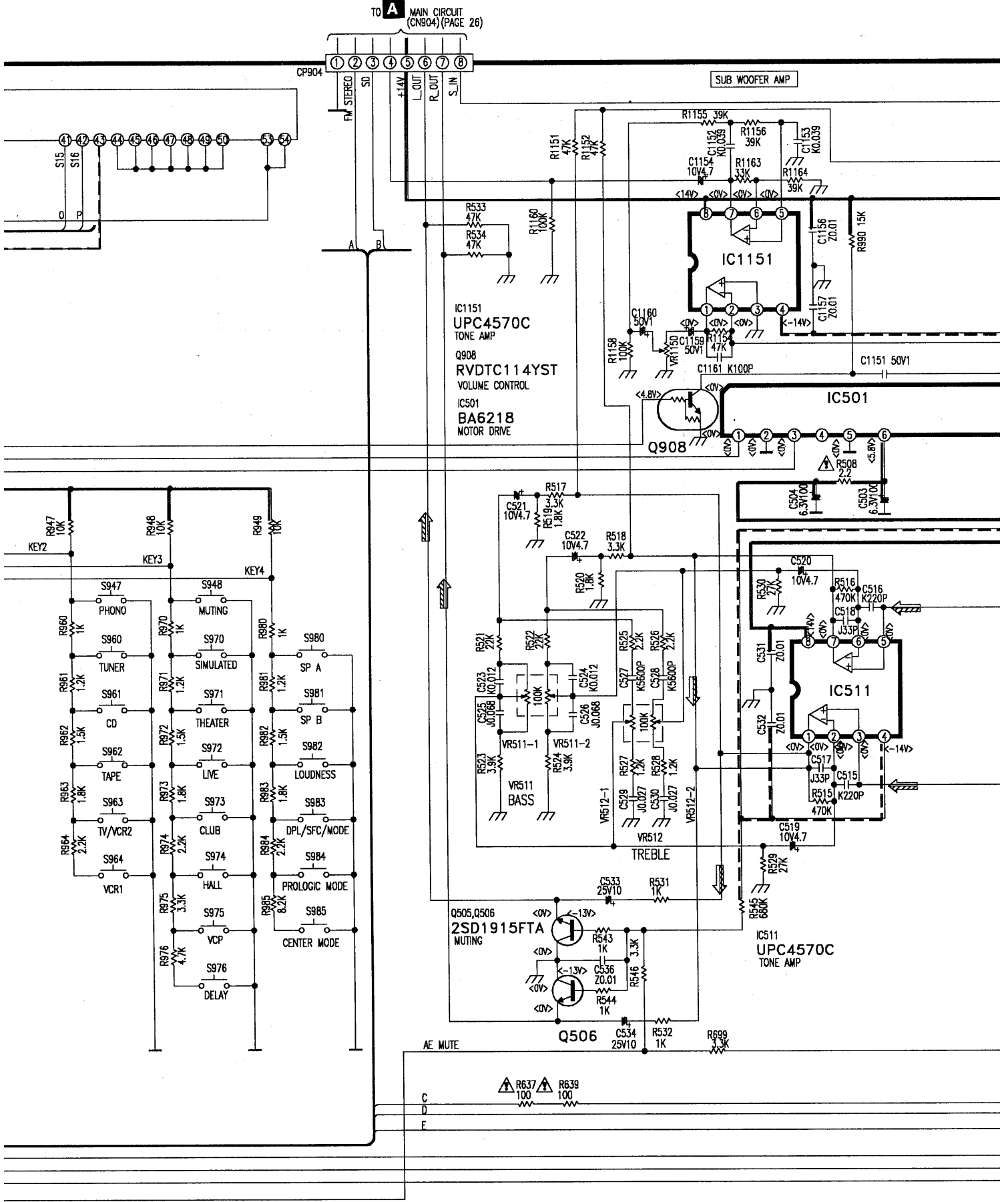

TO **A** MAIN CIRCUIT (CN905) (PAGE 26)

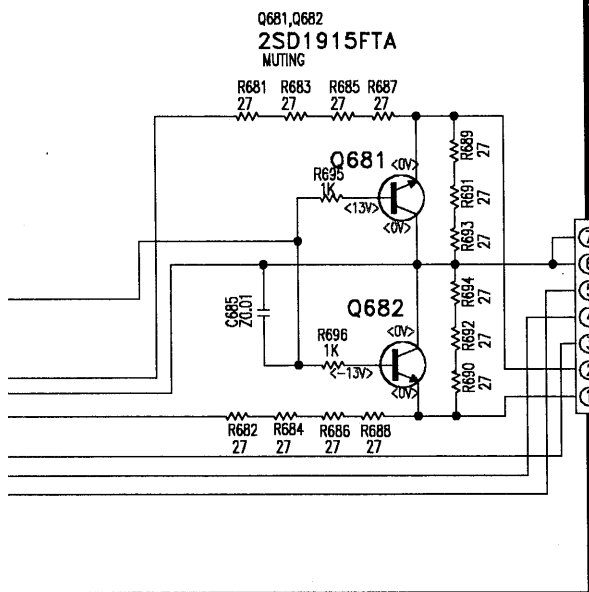
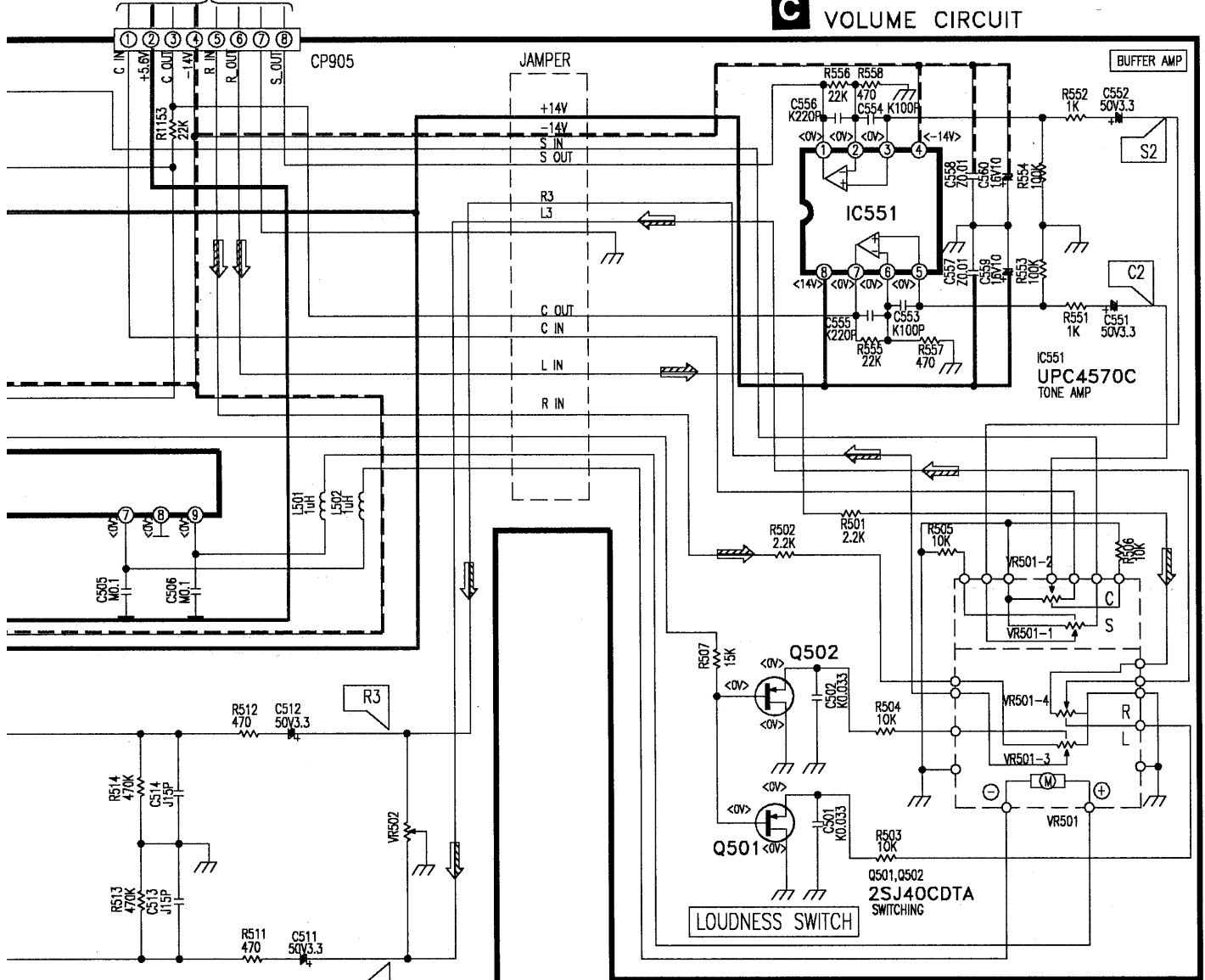

E HEADPHONE JACK CIRCUIT

D POWER SWITCH CIRCUIT

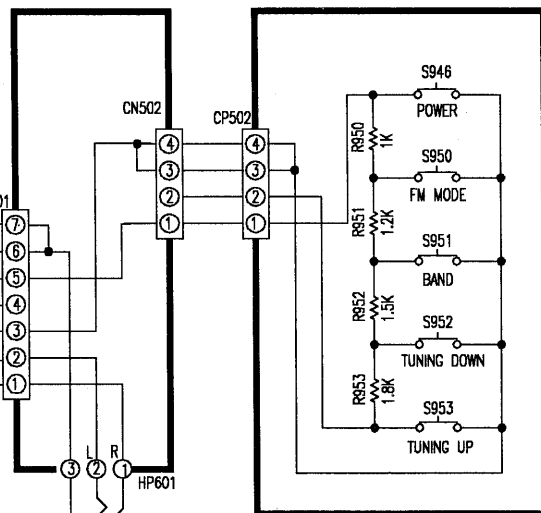

IN/OUT TERMINAL CIRCUIT

SA-EX90

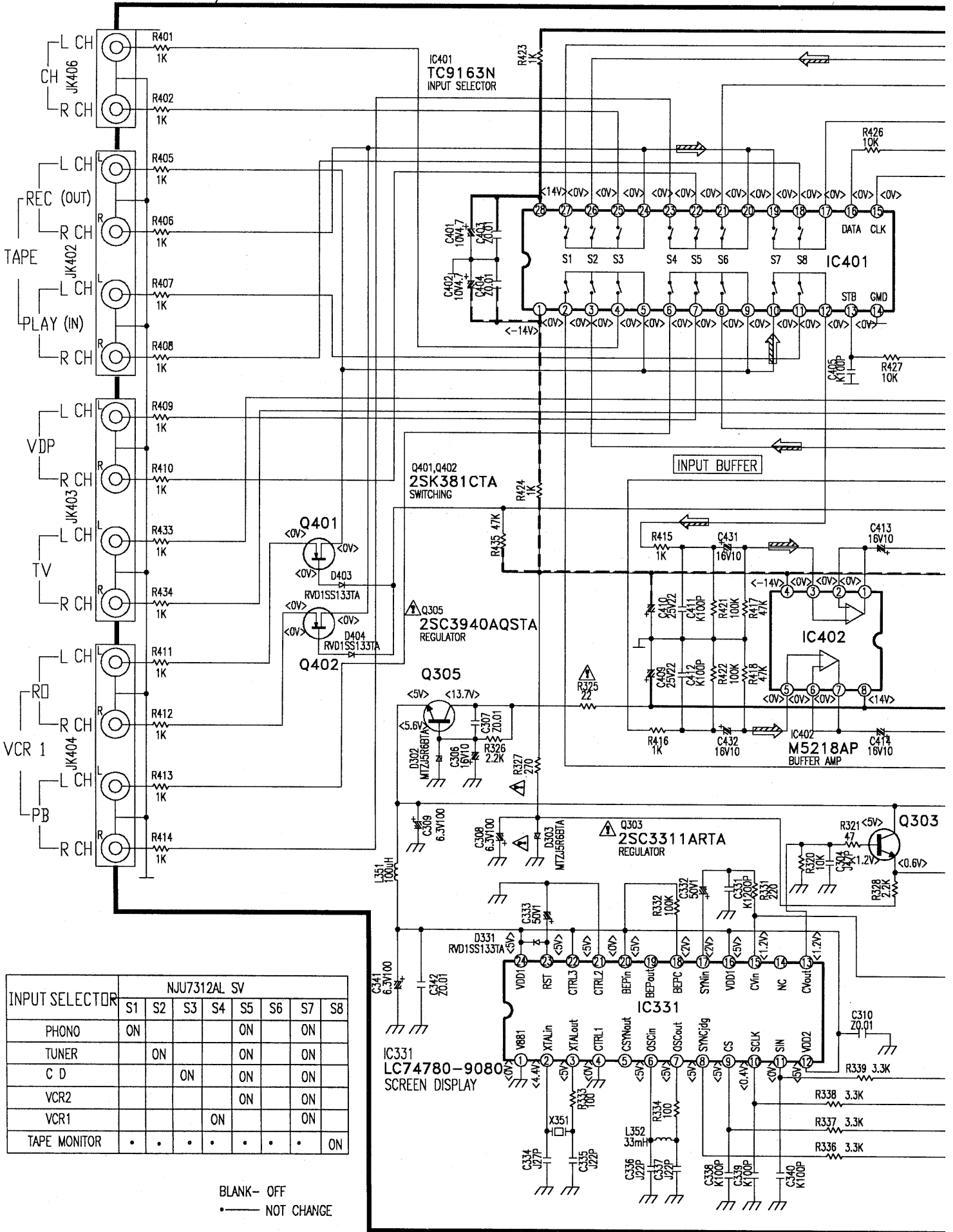

INPUT SELECTOR	NJU7312AL SV							
	S1	S2	S3	S4	S5	S6	S7	S8
PHONO	ON				ON		ON	
TUNER		ON			ON		ON	
C D			ON		ON		ON	
VCR2					ON		ON	
VCR1				ON			ON	
TAPE MONITOR	•	•	•	•	•	•	•	ON

BLANK - OFF
 • - NOT CHANGE

L VCR2 INPUT CIRCUIT

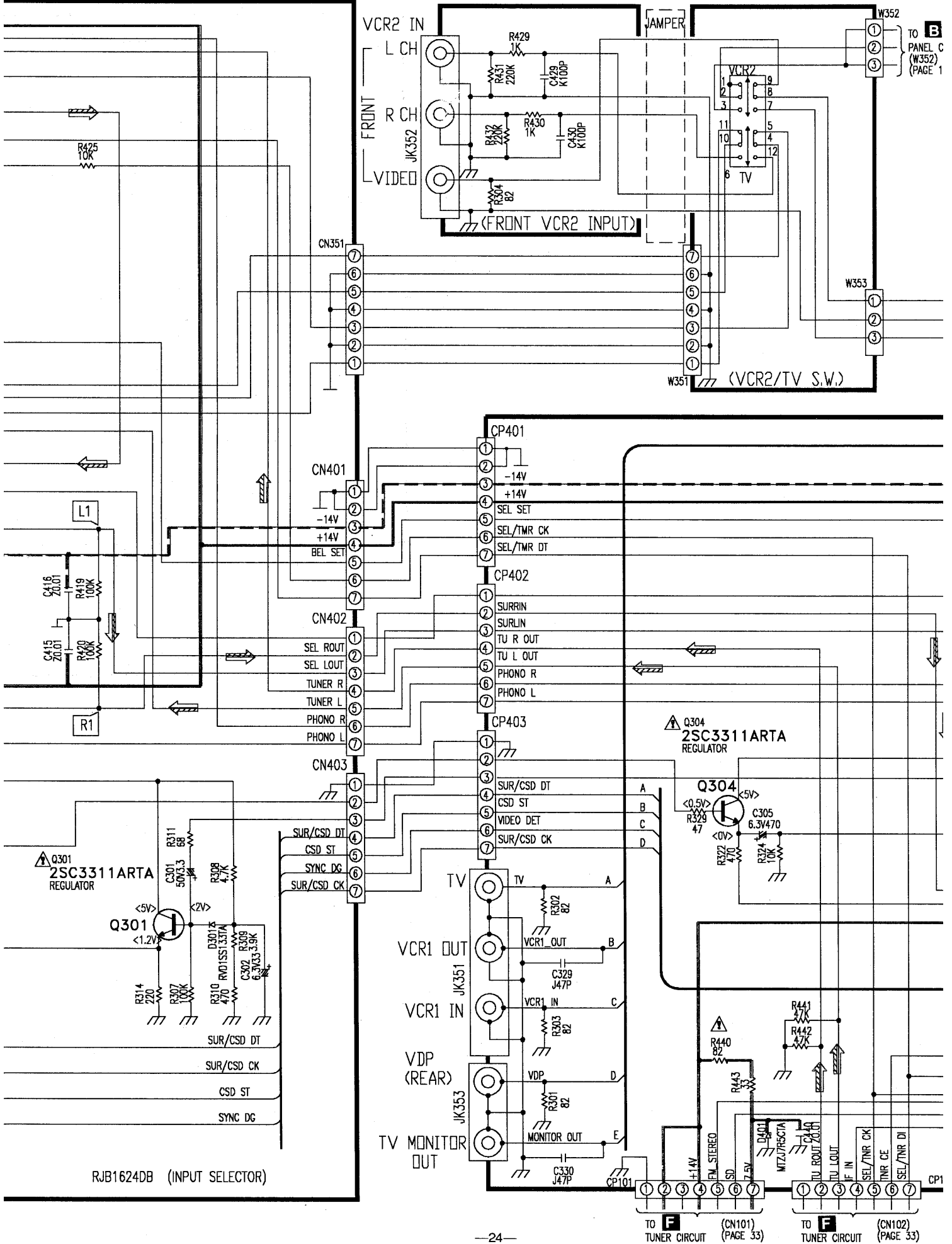

B
TO PANEL C
(W352)
(PAGE 1)

TO **F** TUNER CIRCUIT (CN101) (PAGE 33)
TO **F** TUNER CIRCUIT (CN102) (PAGE 33)

A MAIN CIRCUIT

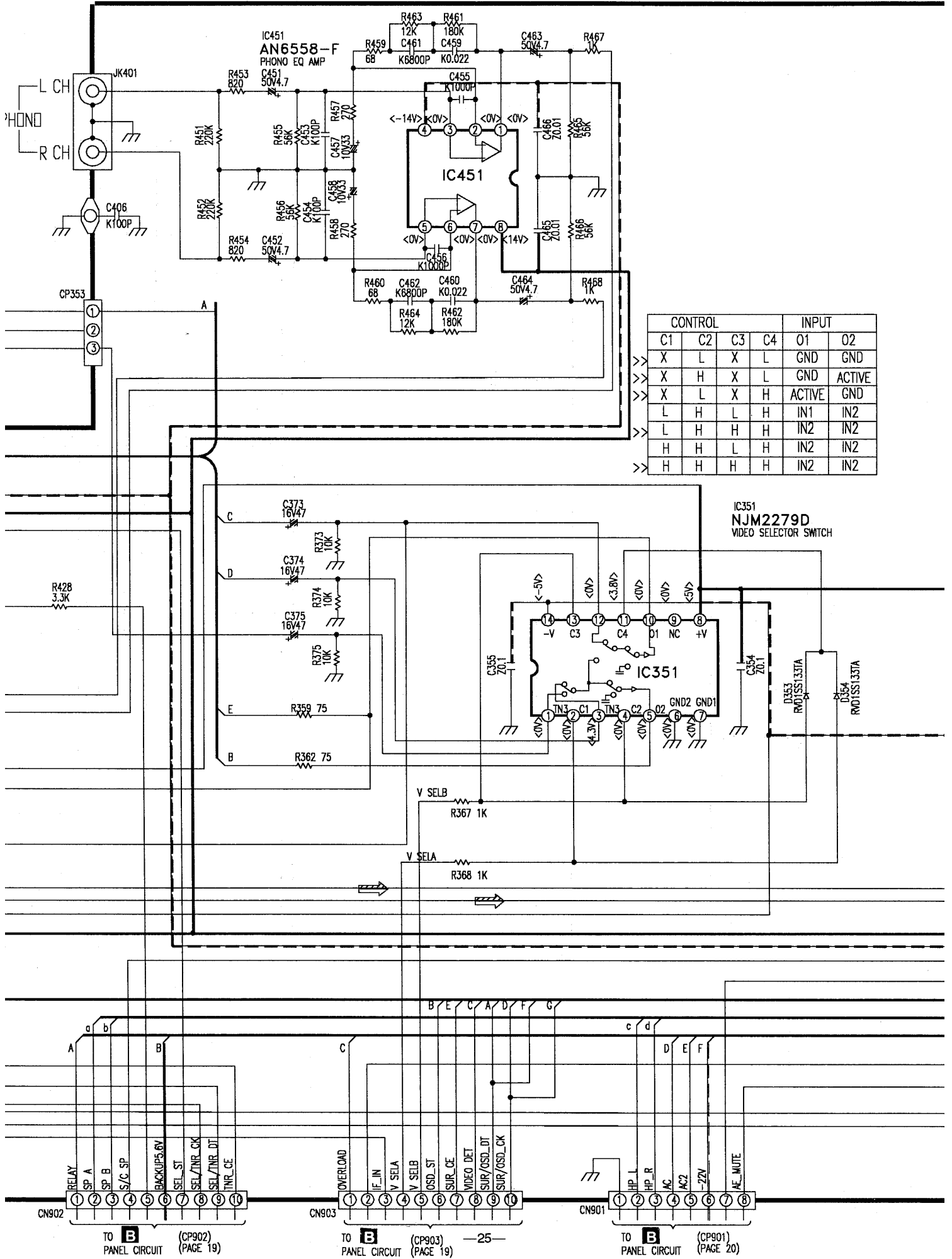

SA-EX900

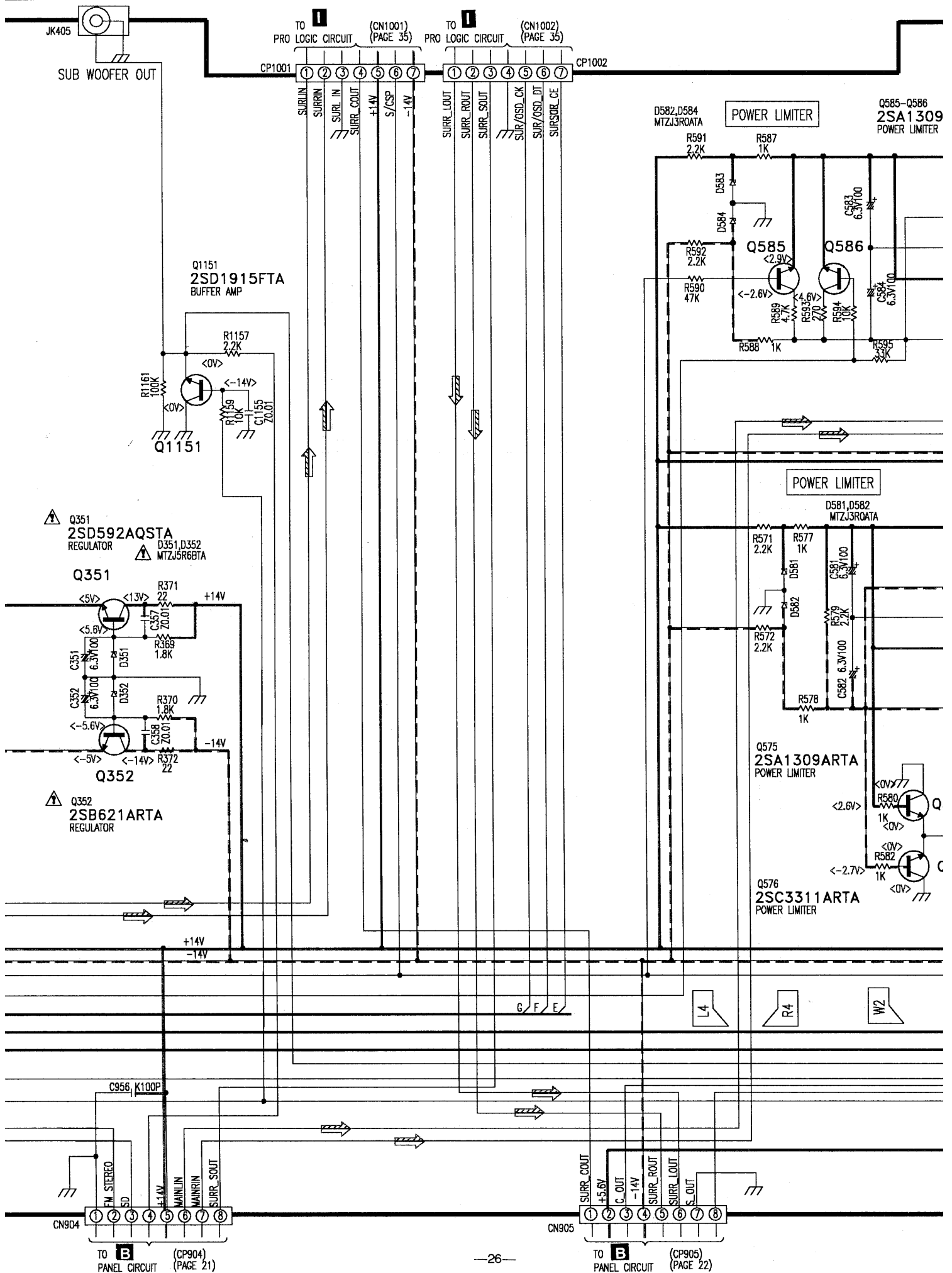

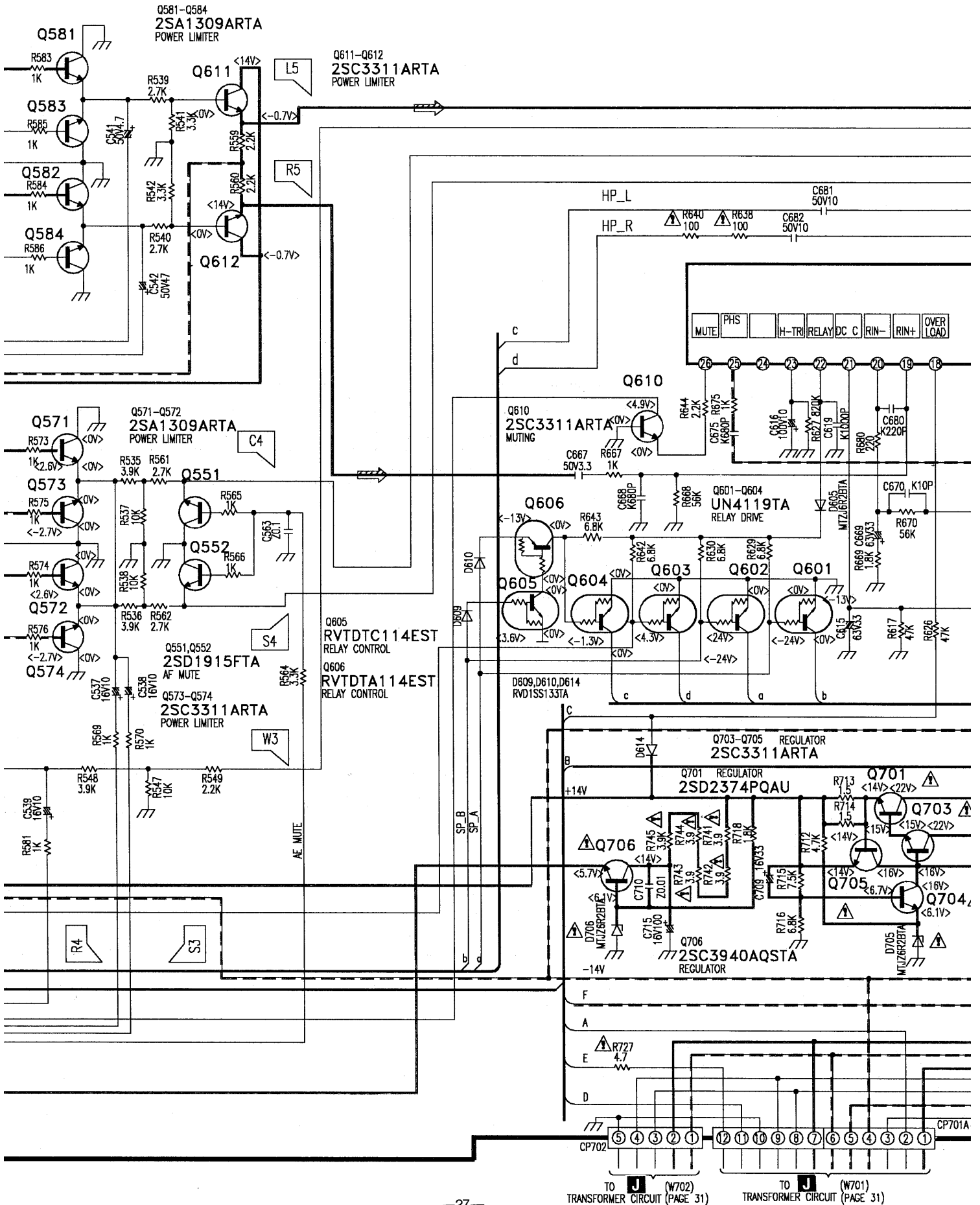

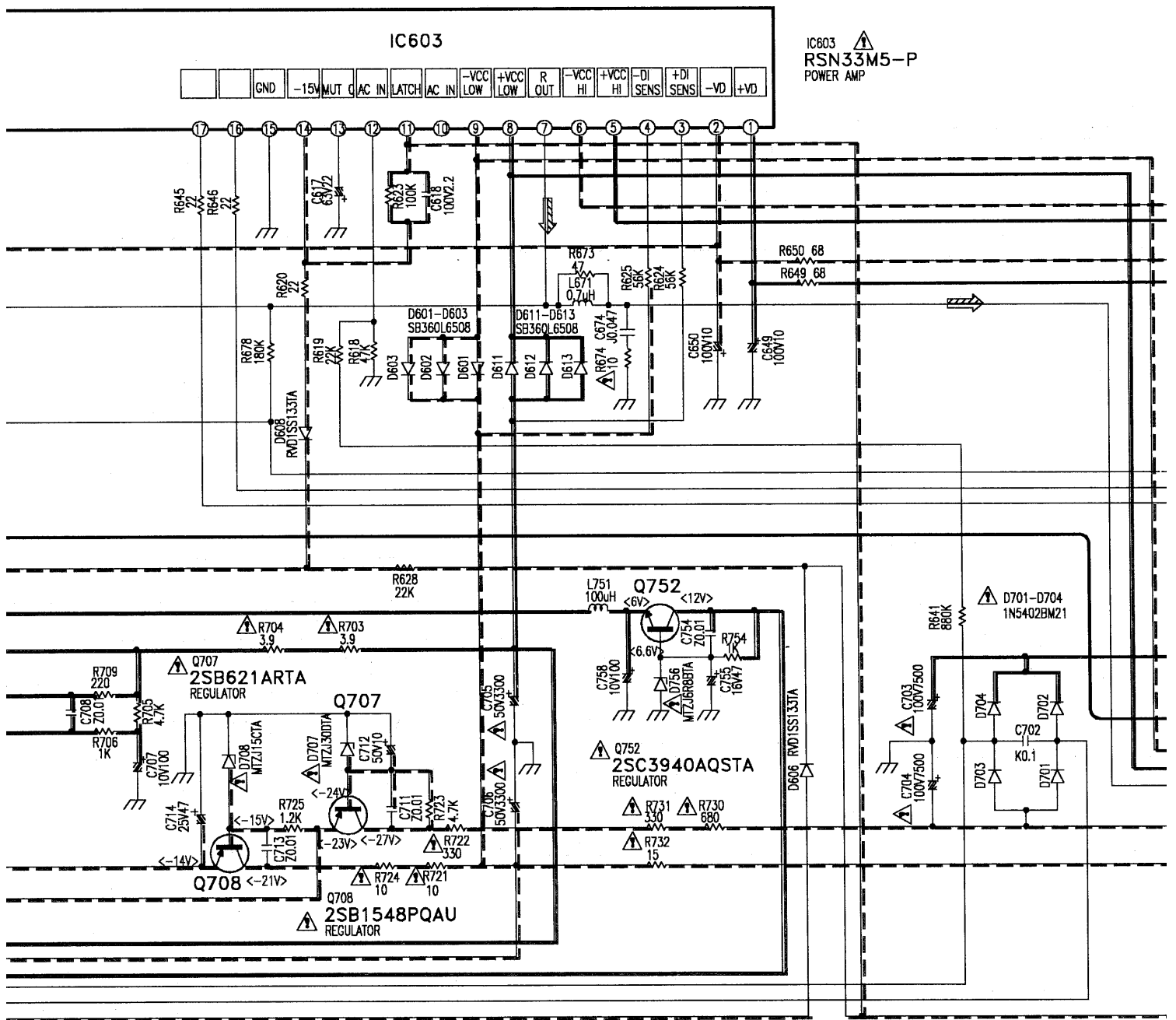

POWER AMP

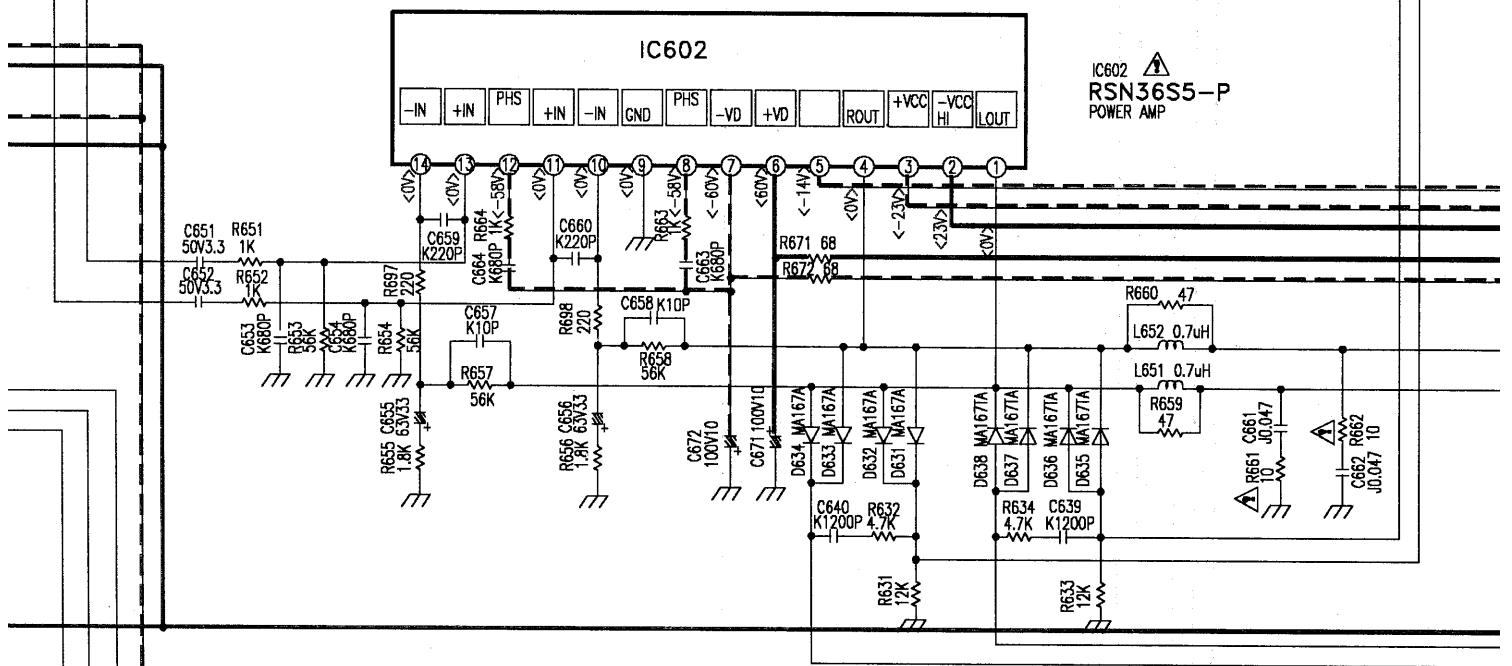
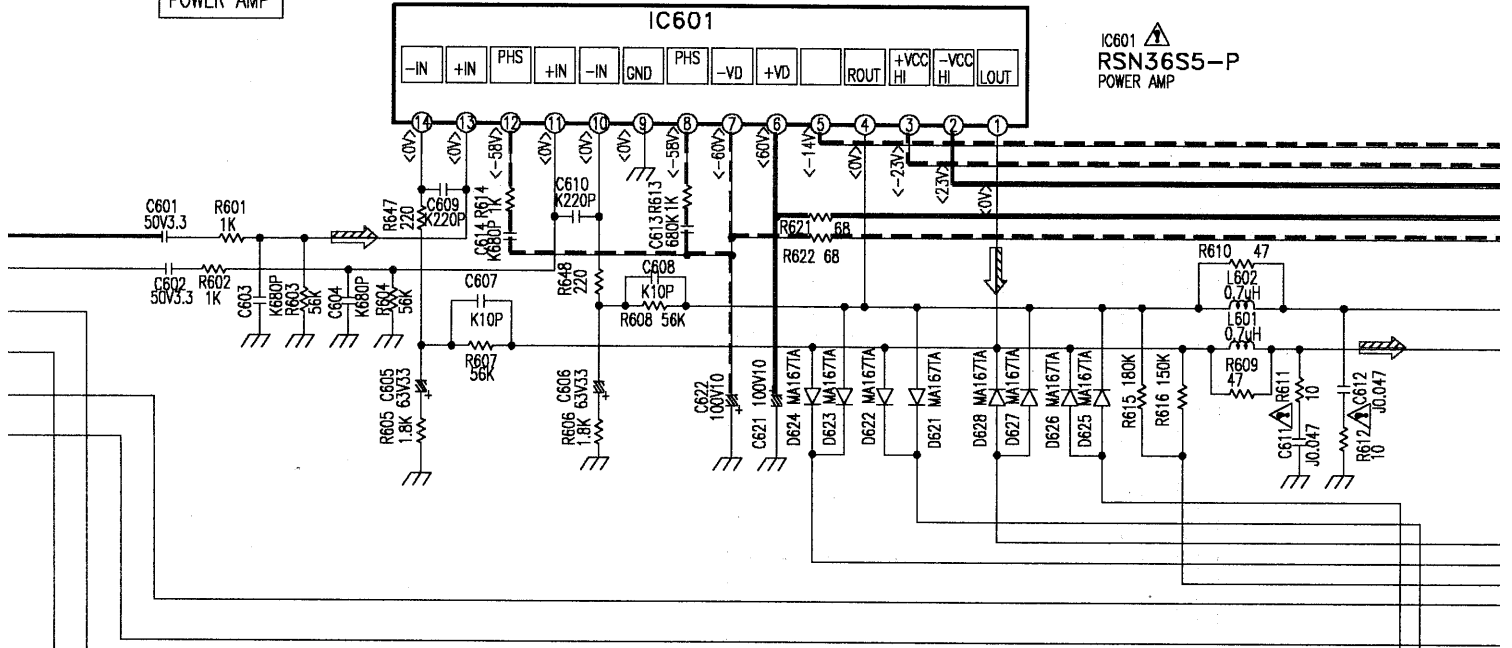

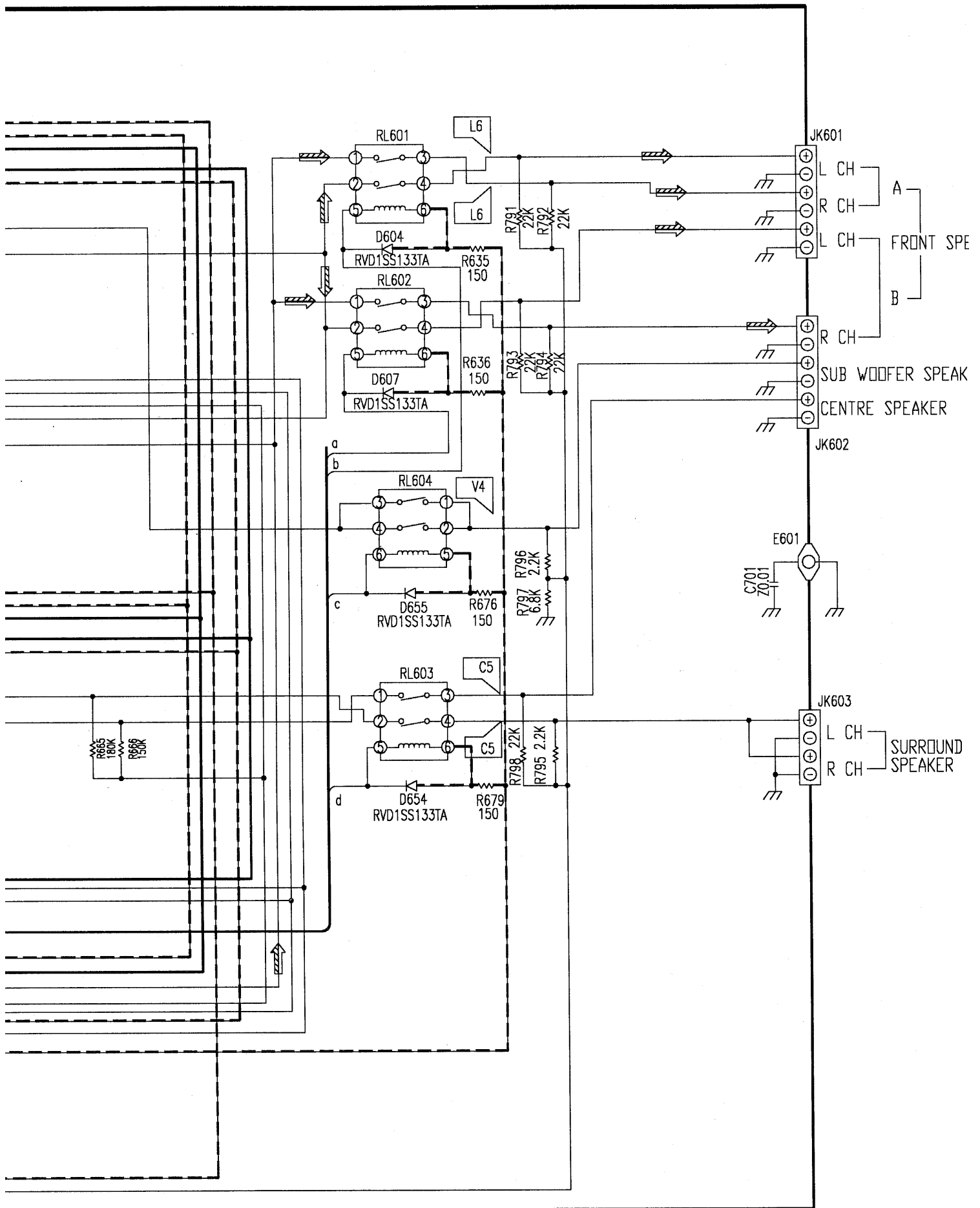

K POWER CIRCUIT

J TRANSFORMER CIRCUIT

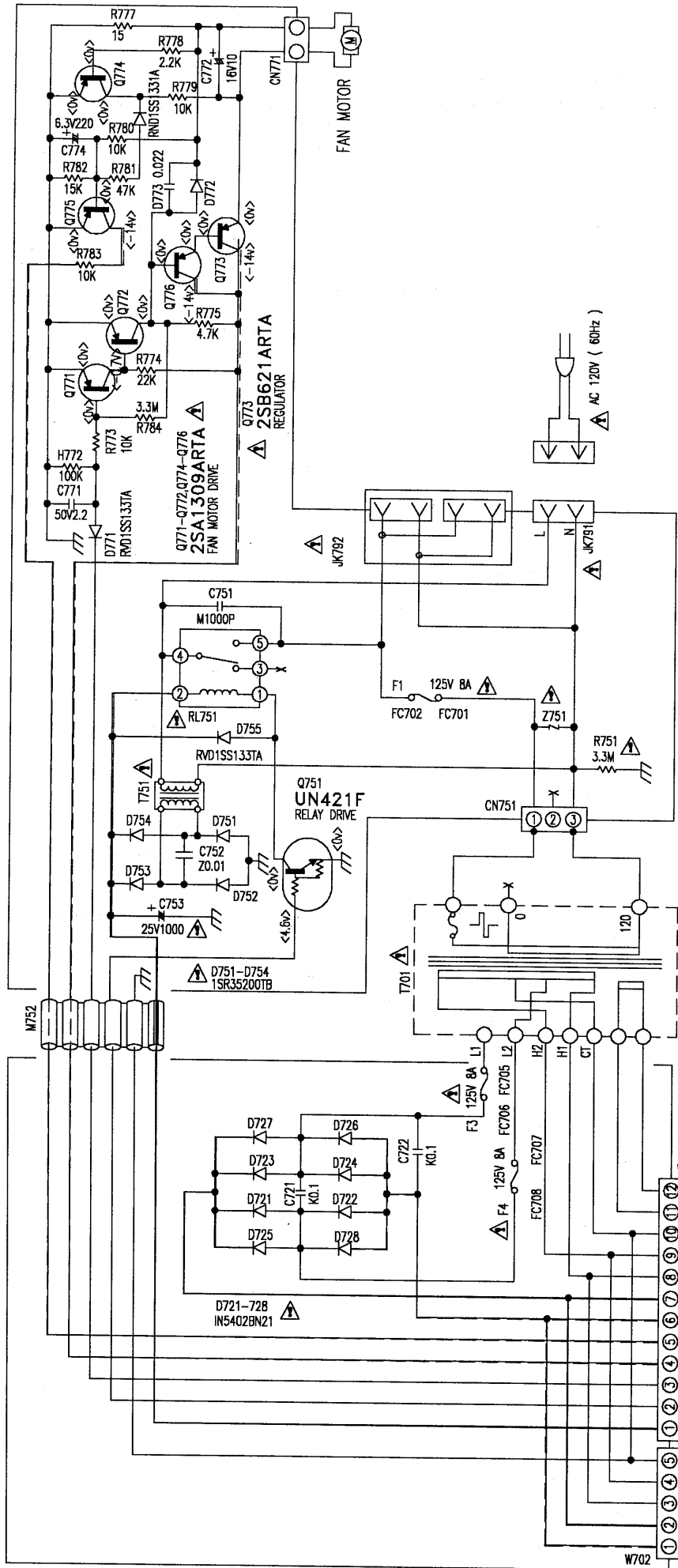

TO **A** (CN702) TO **A** (CP701A) TO **A** (CP701B)
 MAIN CIRCUIT (PAGE 27) MAIN CIRCUIT (PAGE 27) MAIN CIRCUIT (PAGE 27)

G TUNER PACK CIRCUIT

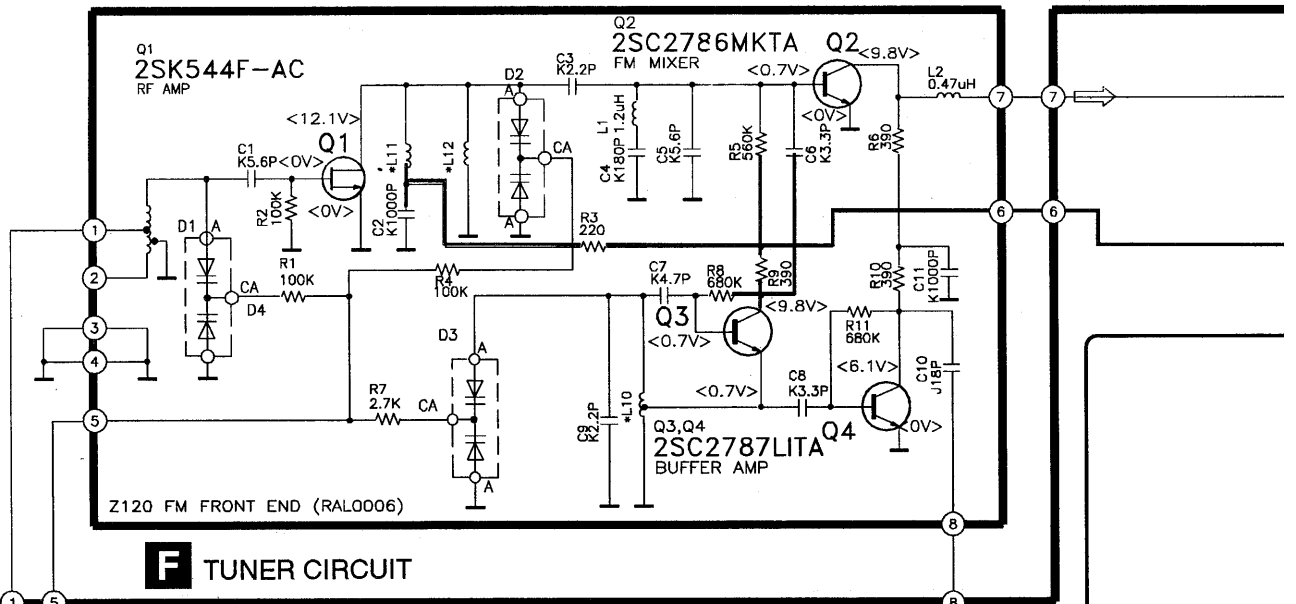

F TUNER CIRCUIT

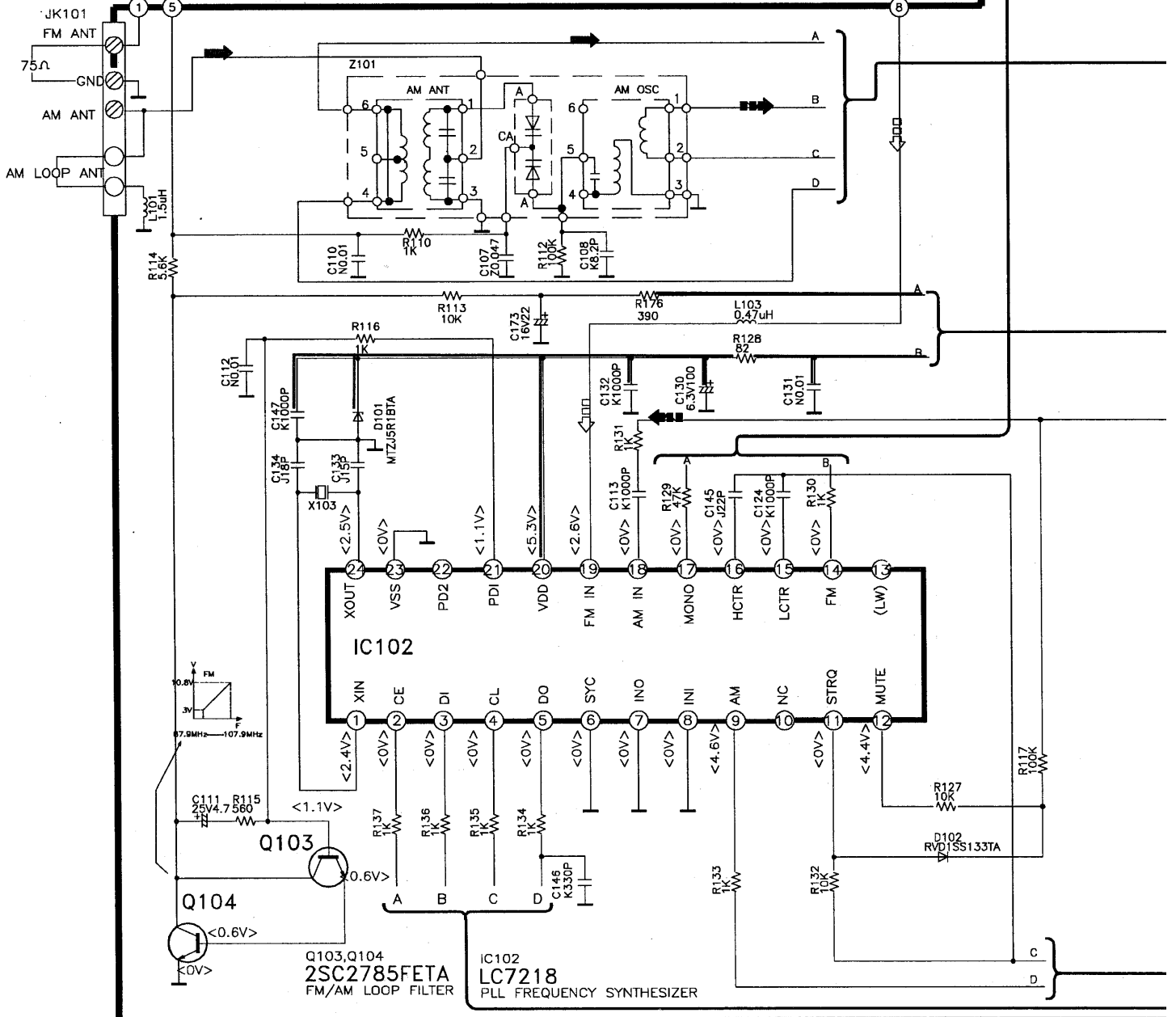

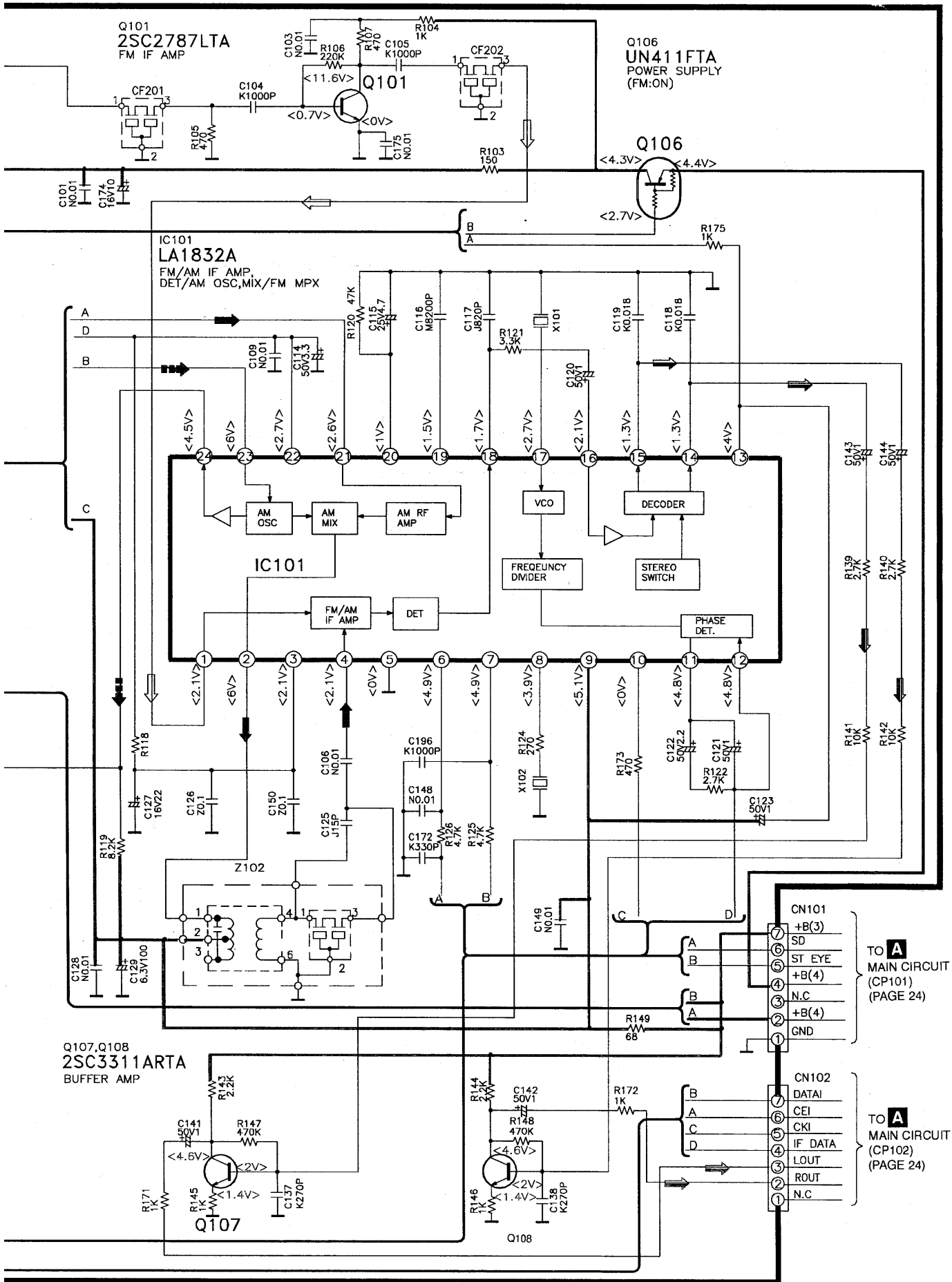

PRO LOGIC CIRCUIT

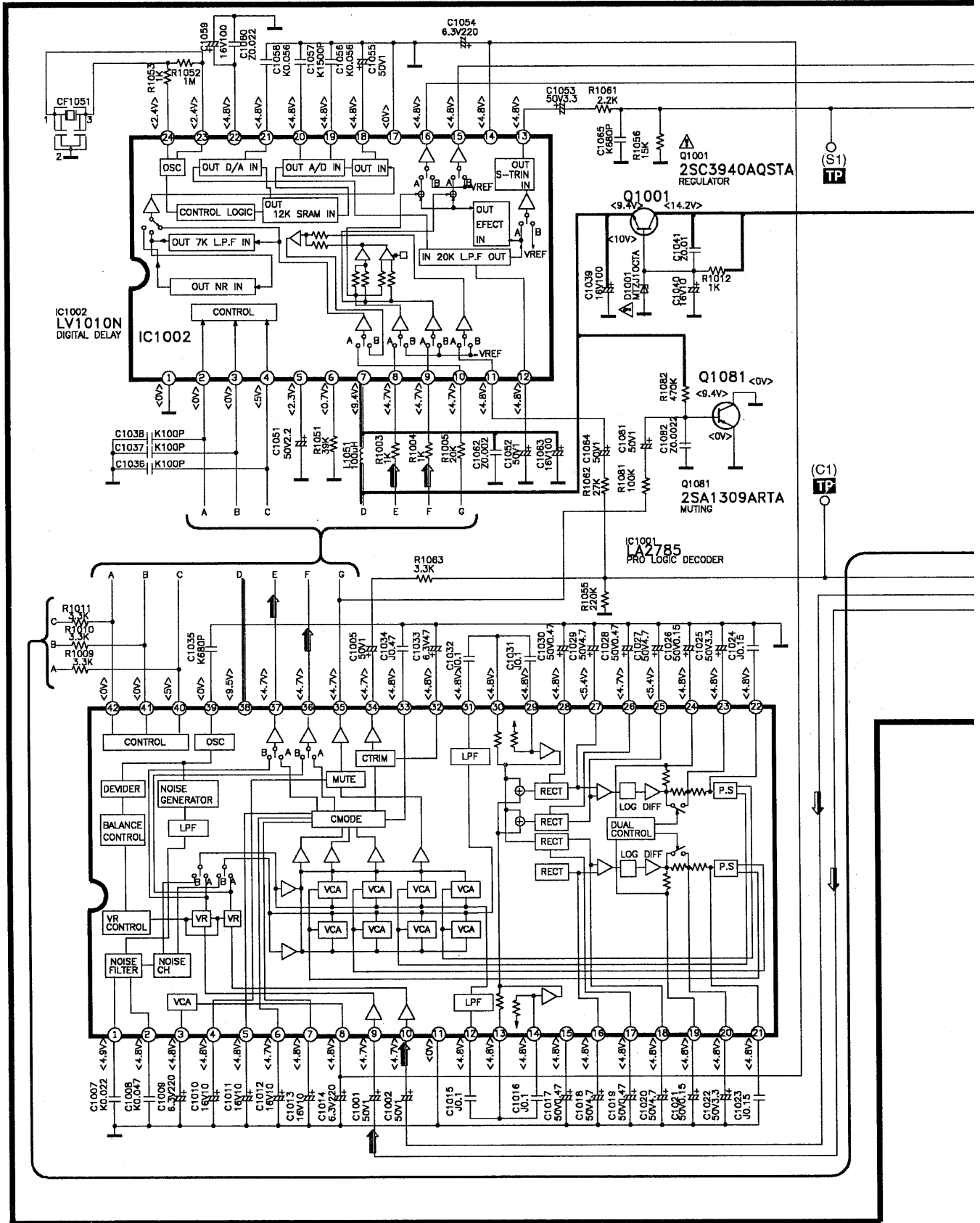

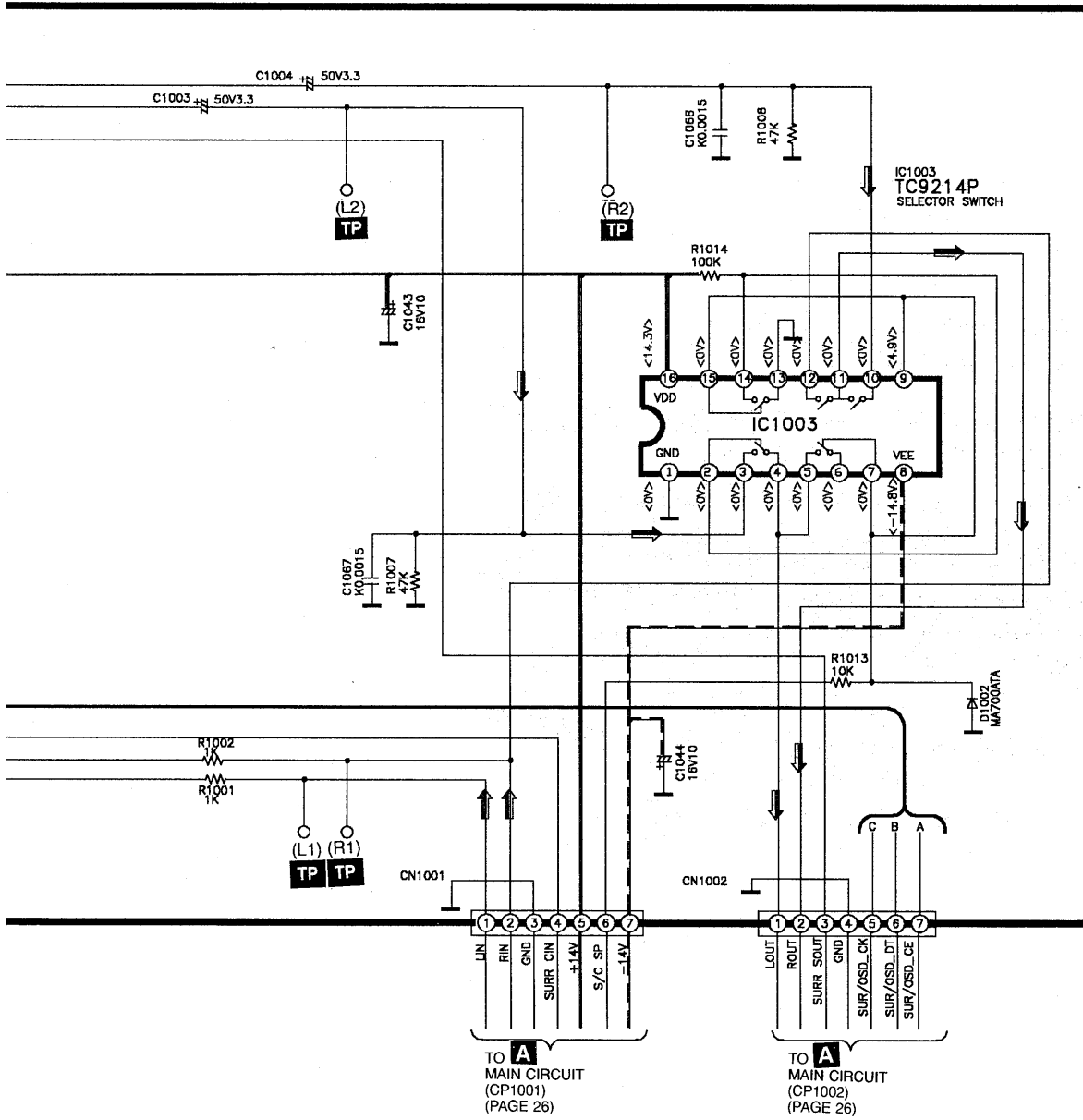

■ Printed Circuit Board

C VOLUME P.C.B. (REP2327A-S)

B PANEL P.C.B. (REP2327A-S)

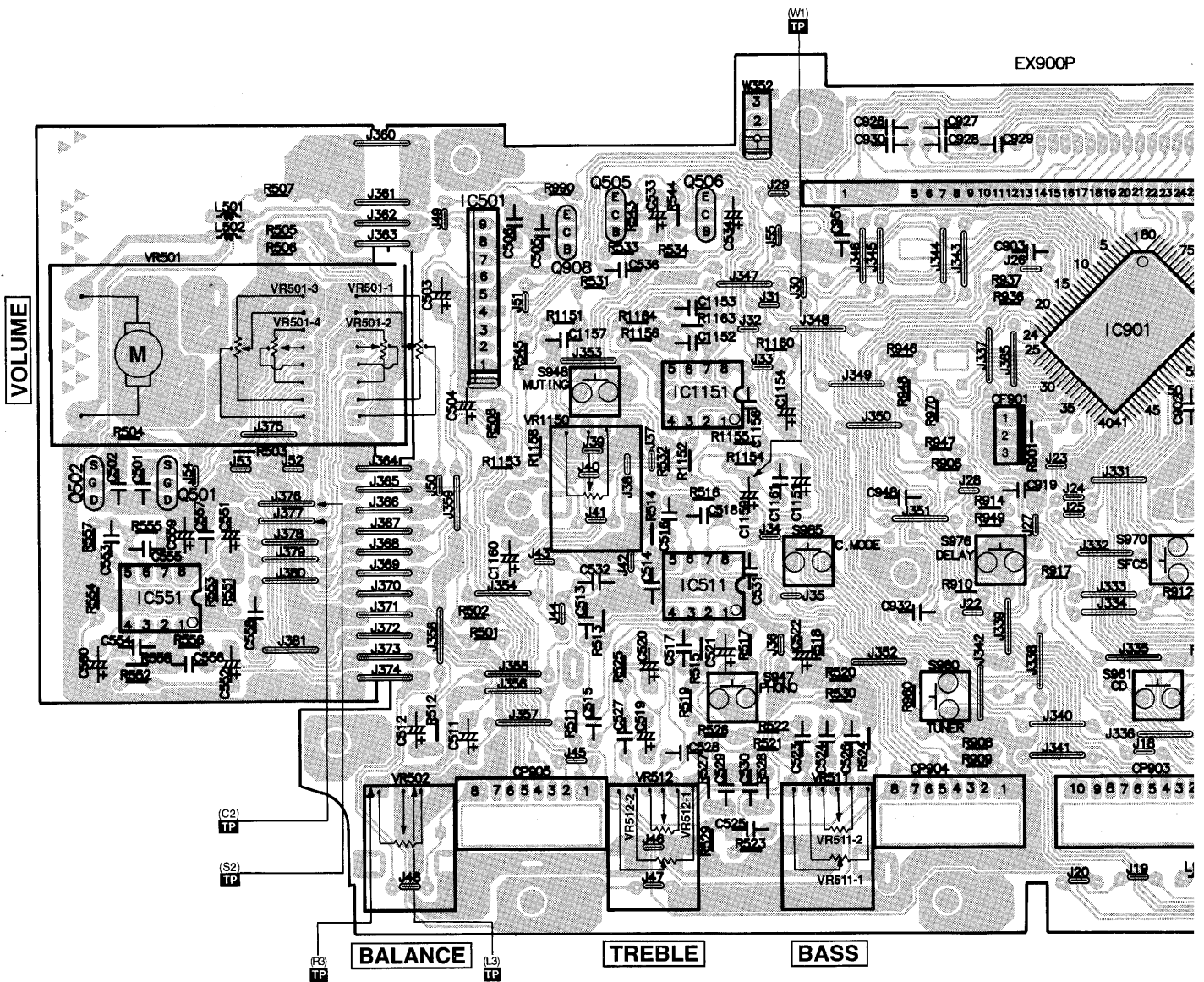

E HEADPHONE JACK P.C.B. (REP2327A-S)

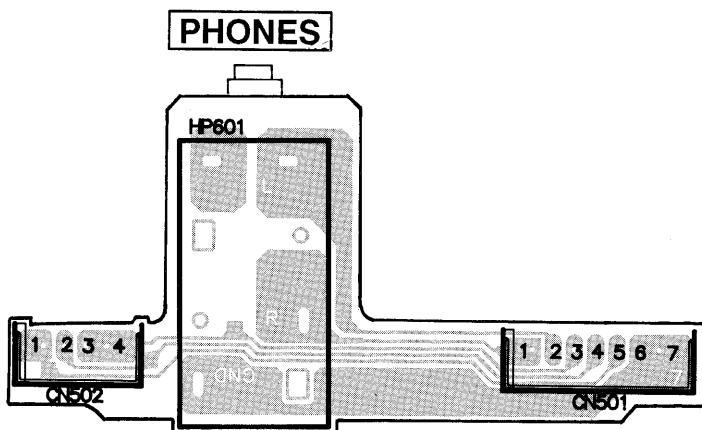

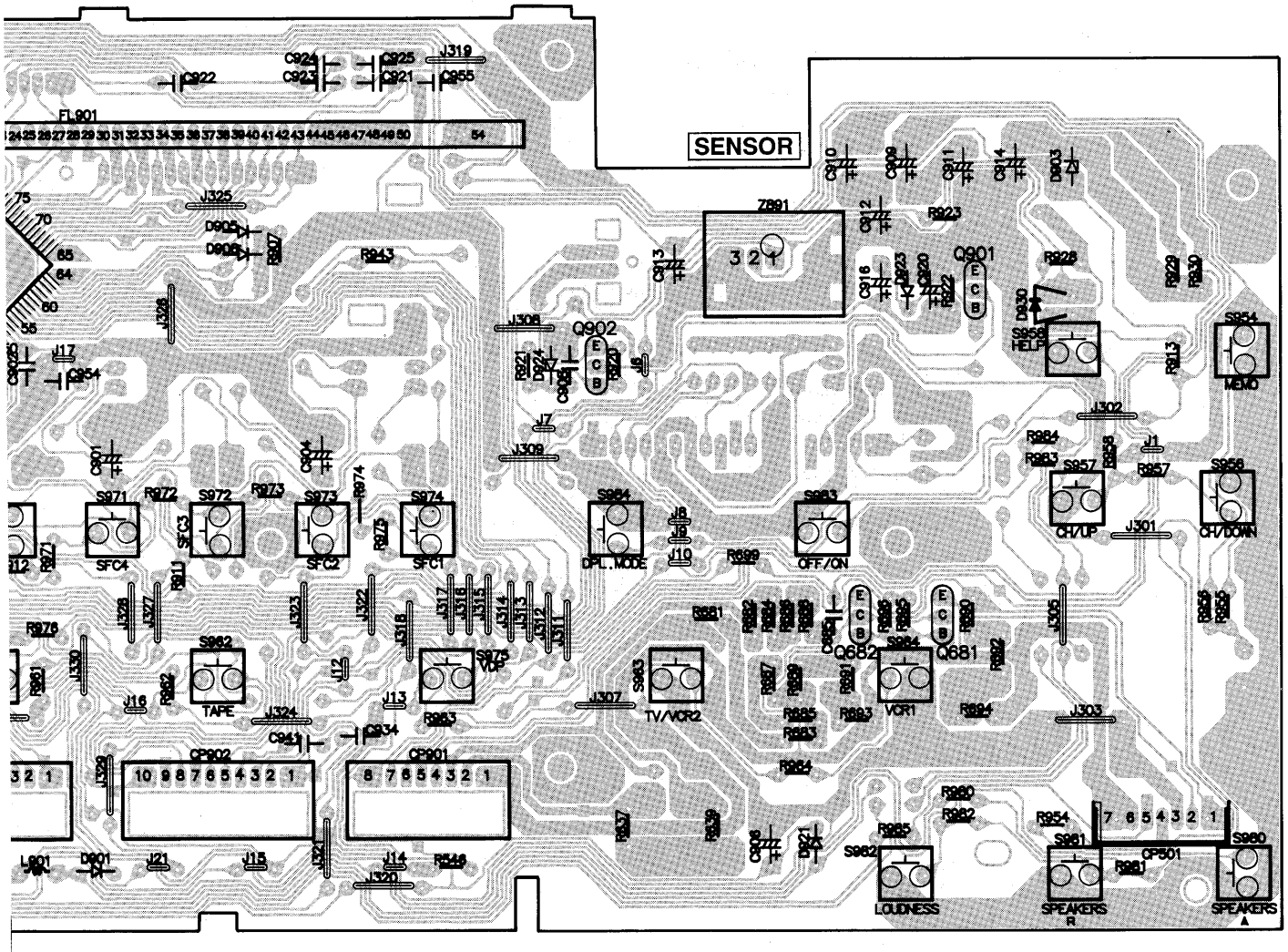

D POWER SWITCH P.C.B. (REP2327A-S)

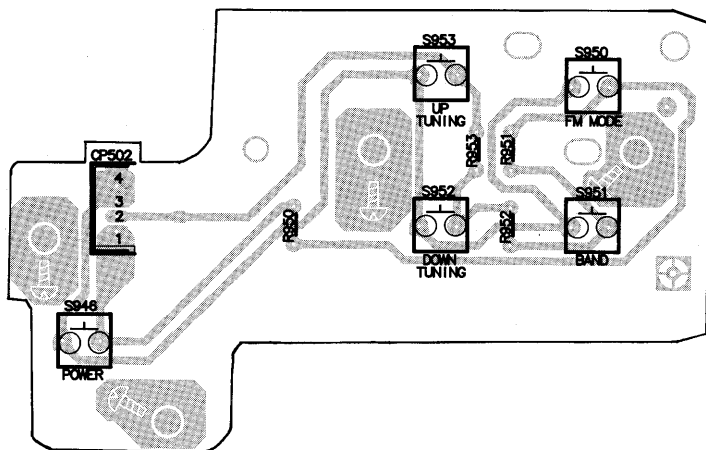

A MAIN P.C.B. (REP2326A-M)

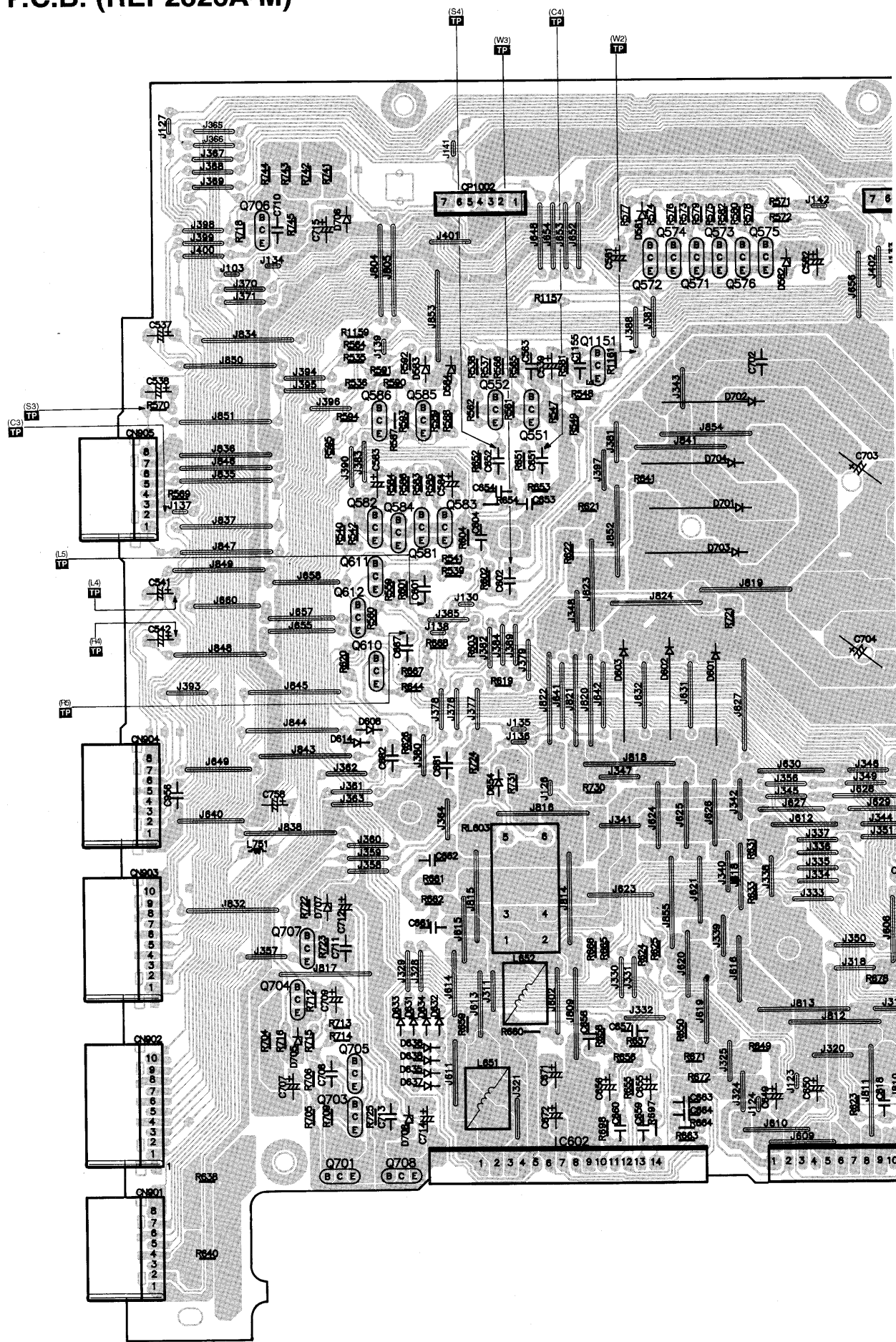

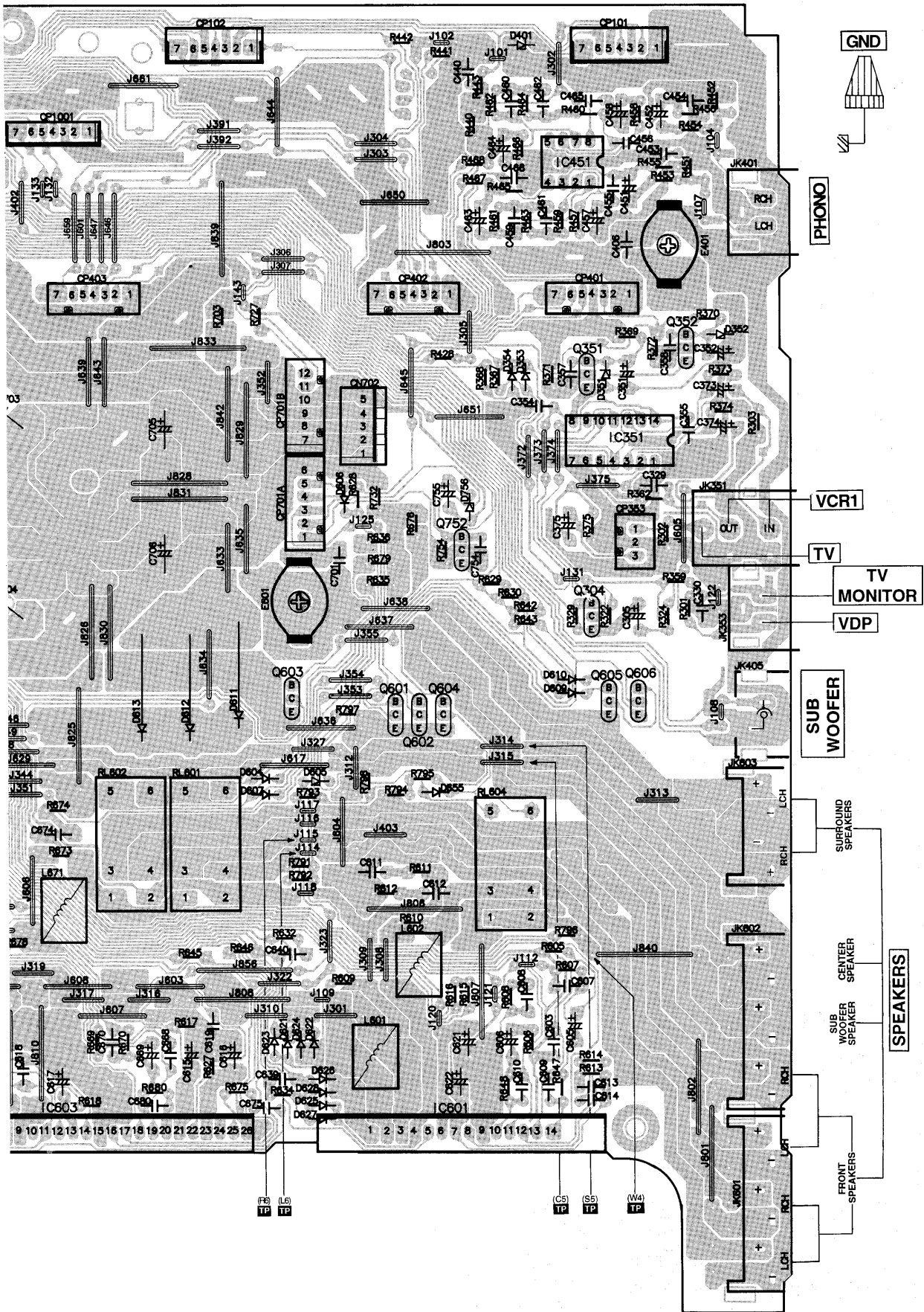

F TUNER P.C.B. (REP2254A-T)

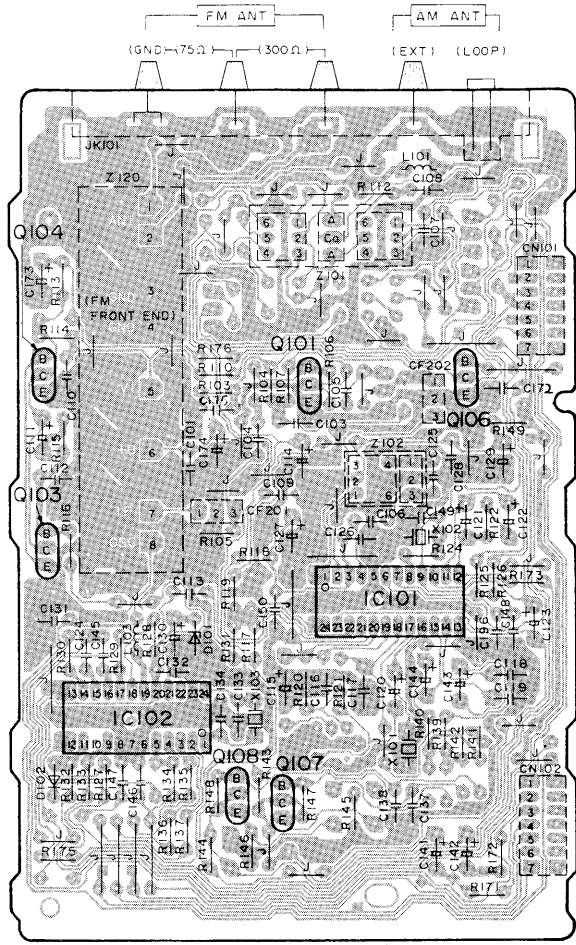

G TUNER PACK P.C.B. (REP1999B)

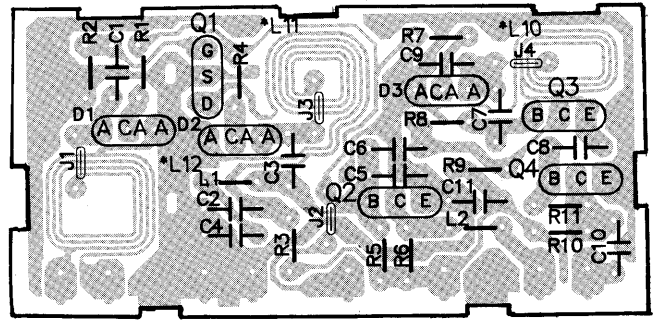

L VCR2 INPUT P.C.B. (REP2327A-S)

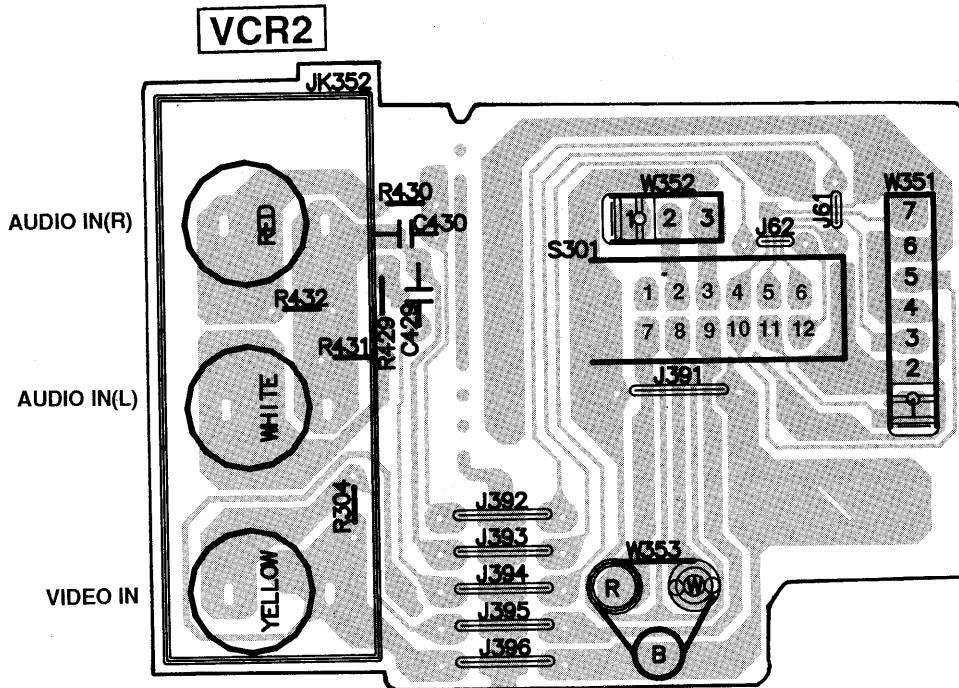

J TRANSFORMER P.C.B. (REP2328A-P ... P) (REP2328B-P ... PC)

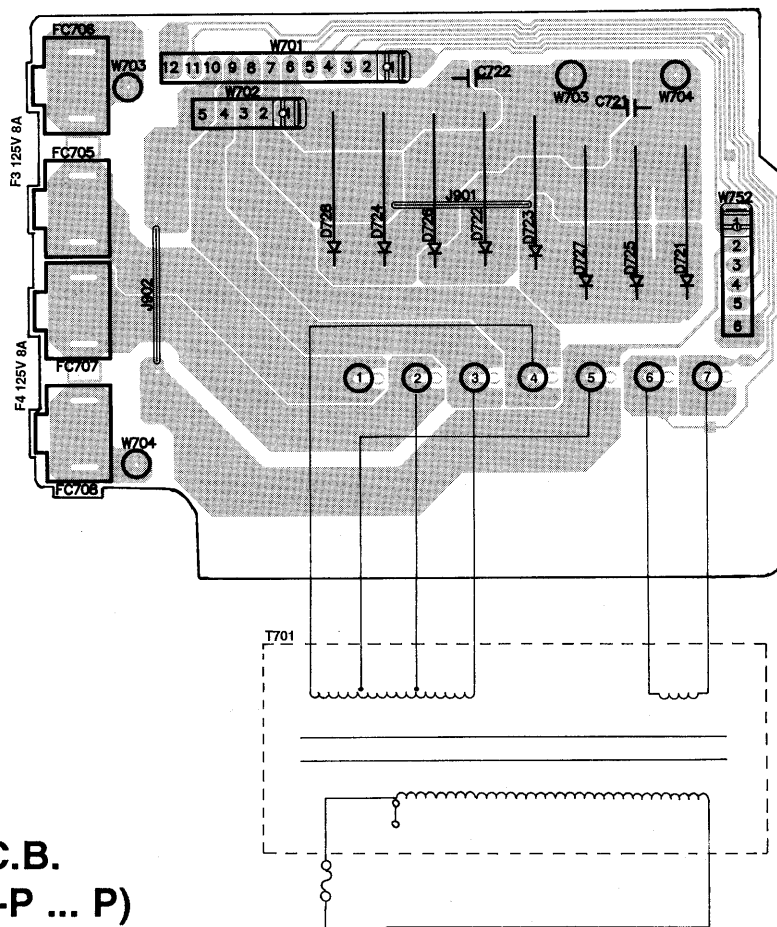

K POWER P.C.B. (REP2328A-P ... P) (REP2328B-P ... PC)

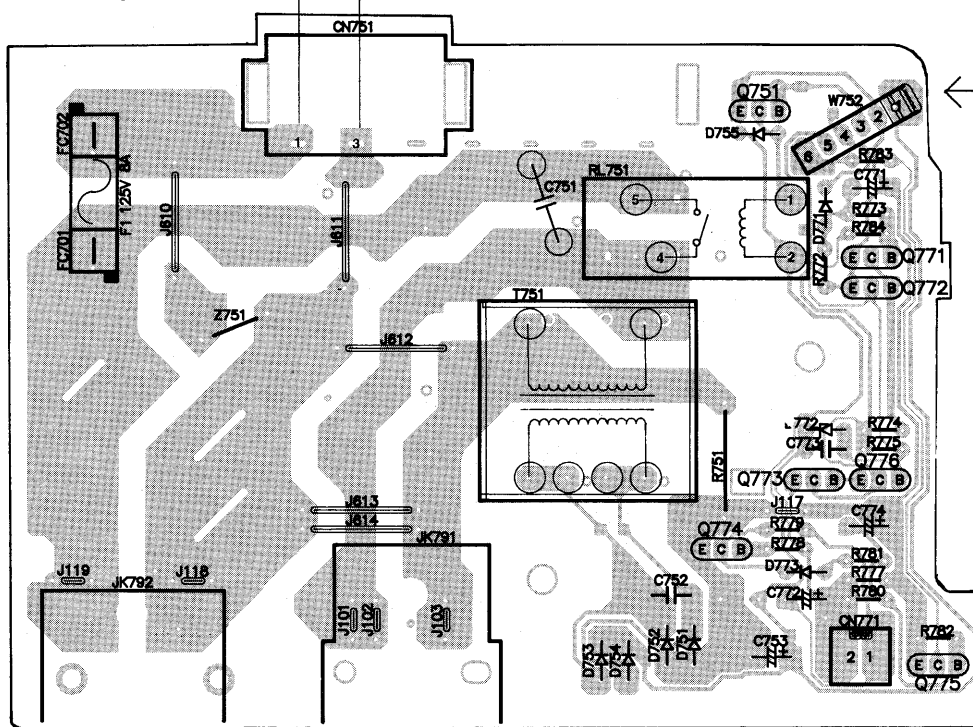

AC OUTLET (SWITCHED)

AC IN ~
120V
60Hz

CAUTION
RISK OF ELECTRIC SHOCK
AC Voltage line. Please
do not touch these 2 P.C.Bs.

I PRO LOGIC P.C.B. (REP2241A-T)

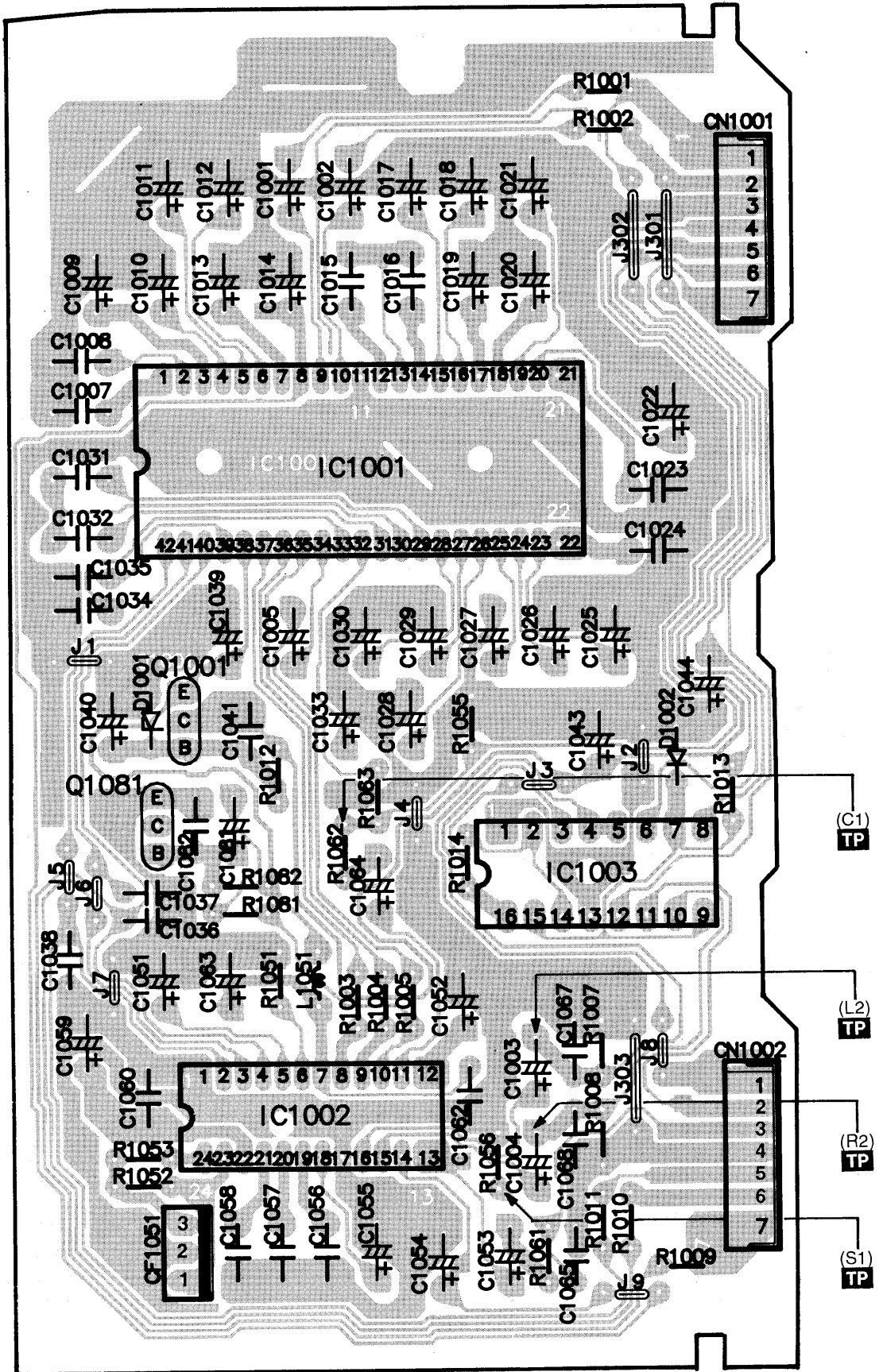

H IN/OUT TERMINAL P.C.B. (REP2328A-P ... P) (REP2328B-P ... PC)

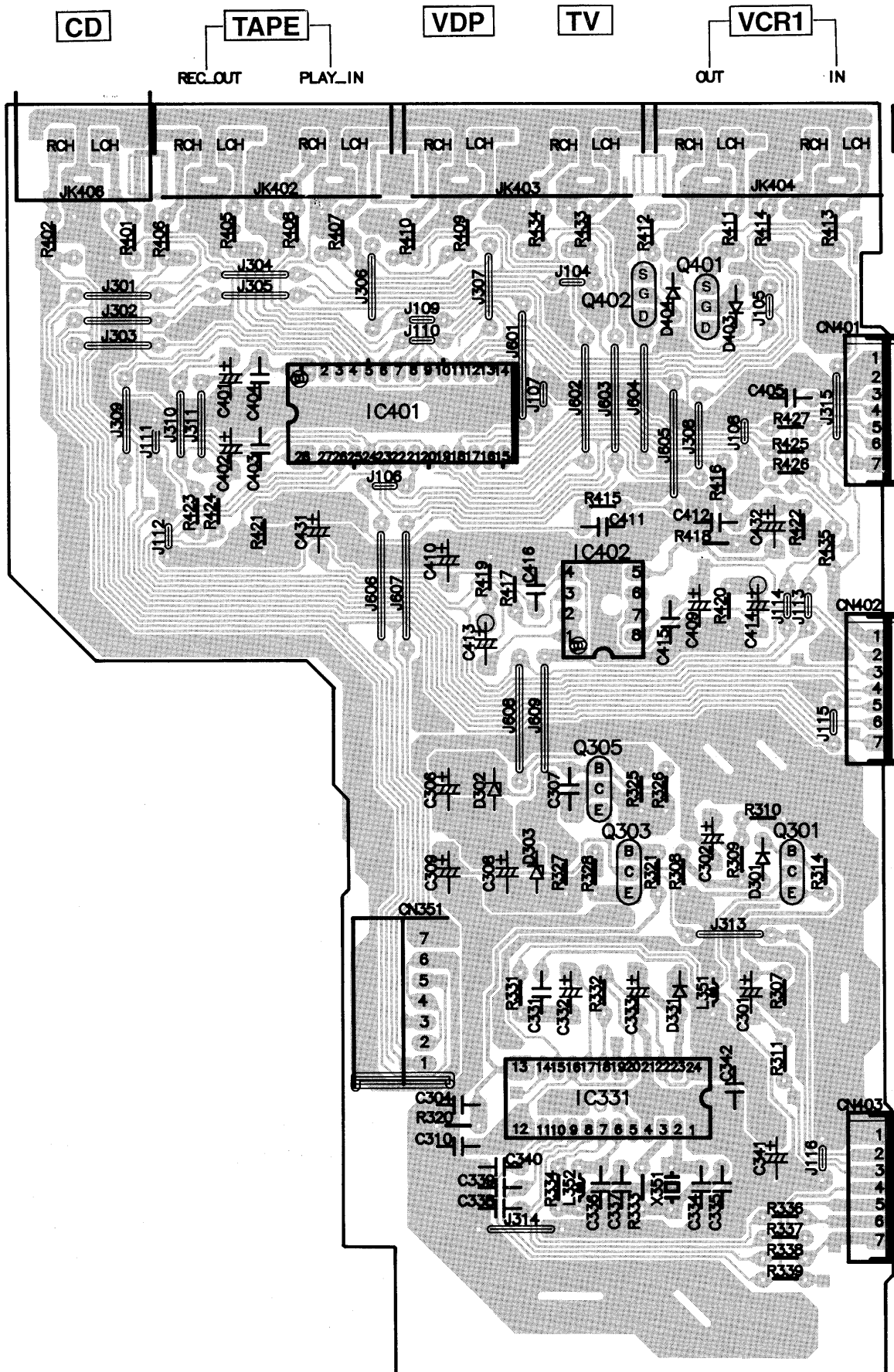

Cabinet Parts Location

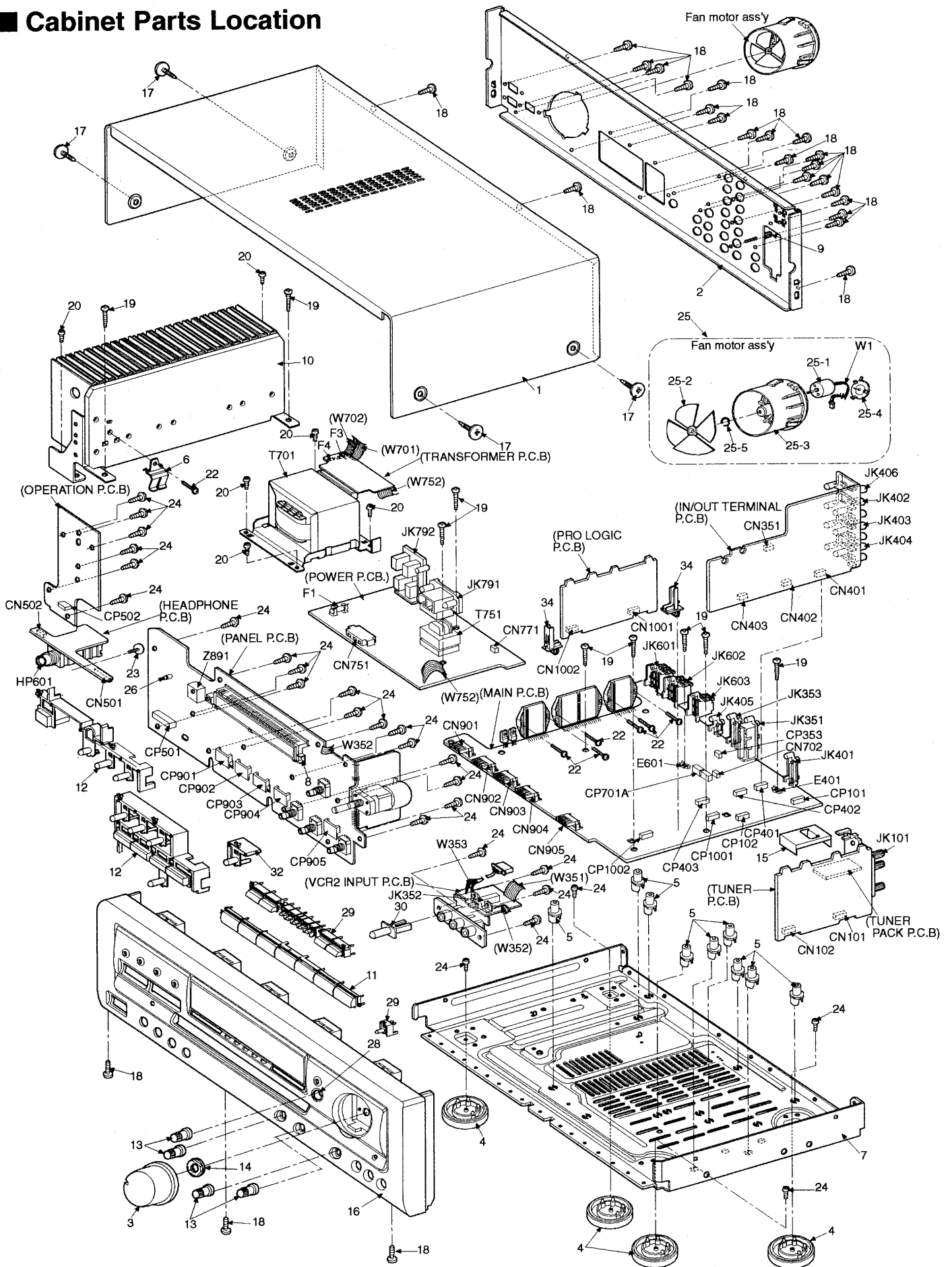

■ Replacement Parts List

Notes: * Important safety notice :

 Components identified by  mark have special characteristics important for safety.

Furthermore, special parts which have purposes of fire-retardant (resistors), high-quality sound (capacitors), low-noise (resistors), etc. are used. When replacing any of components, be sure to use only manufacturer's specified parts shown in the parts list.

* The parenthesized in the Remarks columns specify the areas. (Refer to the cover page for area.)

Parts without these indication can be used for all areas.

* [M] in Remarks column indicates parts that are supplied by MESA.

* [MAV] in Remarks column indicates parts that are supplied by MAV.

* Remote Control Unit : Supply period for three years from terminal of production.

* The "(SF)" mark denotes the standard part.

Ref No	Part No.	Part Name & Description	Remarks	Ref No	Part No.	Part Name & Description	Remarks	Ref No	Part No.	Part Name & Description	Remarks
		CABINET AND CHASSIS				INTEGRATED CIRCUITS		Q352	2SB621ARTA	TRANSISTOR	
1	RKM0325A-K	CABINET	[MAV]	IC101	LA1832A	IC,IF/MPX		Q401	2SK381CTA	TRANSISTOR	
2	RGR0239A-E	BACK PANEL	[MAV](P)	IC102	LC7218	IC,PLL		Q402	2SK381CTA	TRANSISTOR	
2	RGR0239A-F	BACK PANEL	[MAV](PC)	IC331	LC74780-9080	IC, ON SCREAN DISPLA		Q501	2SJ40CDTA	TRANSISTOR	
3	RGW0243A-K	VOLUME KNOB	[MAV]	IC351	NJM2279D	IC, VIDEO SELECTOR S		Q502	2SJ40CDTA	TRANSISTOR	
4	RKA0079-A	FOOT	[MAV]	IC401	TC9163N	IC,SELECTOR		Q505	2SD1915FTA	TRANSISTOR	
5	RKQ0089	PCB HOLDER		IC402	M5218AP	IC,BUFFERAMP		Q506	2SD1915FTA	TRANSISTOR	
6	RMC0158-S	TR FIXTURE	[M]	IC451	AN6558-F	IC,PHONO EQ AMP	[M]	Q551	2SD1915FTA	TRANSISTOR	
7	RMK0320	BOTTOM CHASSIS	[MAV]	IC501	BA6218	IC,MOTOR DRIVER		Q552	2SD1915FTA	TRANSISTOR	
8	RMN0372	FL HOLDER	[MAV]	IC511	UPC4570C	IC,TONE CONTROL		Q571	2SA1309ARTA	TRANSISTOR	
9	SNE2123	EARTH TERMINAL		IC551	UPC4570C	IC, TONE CONTROL IC		Q572	2SA1309ARTA	TRANSISTOR	
10	RXX0171	HEAT SINK UNIT	[MAV]	IC601	RSN36S5-P	IC,HIC	[MAV] 	Q575	2SA1309ARTA	TRANSISTOR	
11	RGU1389-K	SELECTOR BUTTON	[MAV]	IC602	RSN36S5-P	IC, SLAVE HIC	[MAV] 	Q576	2SC3311ARTA	TRANSISTOR	
12	RGU1350B-K	MODE BUTTON	[MAV]	IC603	RSN33M5-P	IC, MASTER HIC	[MAV] 	Q581	2SA1309ARTA	TRANSISTOR	
13	RGW0244-K	BASS TREBLE KNOB	[MAV]	IC901	UPD78043A041	IC,MICRO COMPUTER	[MAV]	Q582	2SA1309ARTA	TRANSISTOR	
14	RHN90001	M9 NUT		IC1001	LA2785	IC, PRO LOGIC DECODE		Q583	2SC3311ARTA	TRANSISTOR	
15	RSC0027-1	TUNER PACK		IC1002	LV1010N	IC, DIGITAL DELAY IC		Q584	2SC3311ARTA	TRANSISTOR	
16	RFKGE900PK	FRONT PANEL ASS'Y	[MAV]	IC1003	TC9214P	IC, SELECTOR SWITCH		Q585	2SA1309ARTA	TRANSISTOR	
17	SNE2129-1	SCREW (CABINET)		IC1151	UPC4570C	IC, TONE CONTROL IC		Q586	2SA1309ARTA	TRANSISTOR	
18	XTBS3+8JFZ1	SCREW (MAIN PCB)						Q601	UN4119TA	TRANSISTOR	
19	XTB3+20JFZ	SCREW (TRNFM/H SINK)						Q602	UN4119TA	TRANSISTOR	
20	XTB3+8FFZ	SCREW (REAR PANEL)						Q603	UN4119TA	TRANSISTOR	
22	XTW3+15T	SCREW (HEAT SINK)		Q1	2SK544F-AC	TRANSISTOR		Q604	UN4119TA	TRANSISTOR	
23	RHD26016	SCREW (PANEL)		Q2	2SC2786MTA	TRANSISTOR		Q605	RVTDTTC114EST	TRANSISTOR	
24	XTBS26+10J	SCREW		Q3	2SC2787FL1TA	TRANSISTOR		Q606	RVTDTA114EST	TRANSISTOR	
25	RYQ0173-K	FAN UNIT	[MAV]	Q4	2SC2787FL1TA	TRANSISTOR		Q610	2SC3311ARTA	TRANSISTOR	
25-1	MDN-4RB4MRC	MOTOR		Q101	2SC2787LTA	TRANSISTOR		Q611	2SC3311ARTA	TRANSISTOR	
25-2	SHE232	64MM FAN		Q103	2SC2785FETA	TRANSISTOR		Q612	2SC3311ARTA	TRANSISTOR	
25-3	SHE233-1	FAN CASE		Q104	2SC2785FETA	TRANSISTOR		Q681	2SD1915FTA	TRANSISTOR	
25-4	SHE234	FAN CASE COVER		Q106	UN411FTA	TRANSISTOR		Q682	2SD1915FTA	TRANSISTOR	
25-5	SUS271	MOTOR SPRING		Q107	2SC3311ARTA	TRANSISTOR		Q701	2SD2374PQAU	TRANSISTOR	
26	RMN0313	LED SUPPORT		Q108	2SC3311ARTA	TRANSISTOR		Q703	2SC3311ARTA	TRANSISTOR	
28	RGK0806-N	VOLUME RING	[MAV]	Q301	2SC3311ARTA	TRANSISTOR		Q704	2SC3311ARTA	TRANSISTOR	
29	RGU1352-K	DOLBY BUTTON	[MAV]	Q303	2SC3311ARTA	TRANSISTOR		Q705	2SC3311ARTA	TRANSISTOR	
30	RGU1390-K	VCR2 BUTTON	[MAV]	Q304	2SC3311ARTA	TRANSISTOR		Q706	2SC3940AQSTA	TRANSISTOR	
32	RGU1398-Q	HELP BUTTON	[MAV]	Q305	2SC3940AQSTA	TRANSISTOR		Q707	2SB621ARTA	TRANSISTOR	
34	RMN0203	PCB SUPPORT		Q351	2SD592AQSTA	TRANSISTOR	[MAV] 	Q708	2SB1548PQAU	TRANSISTOR	

Ref No	Part No.	Part Name & Description	Remarks	Ref No	Part No.	Part Name & Description	Remarks	Ref No	Part No.	Part Name & Description	Remarks
Q751	UN421FTA	TRANSISTOR		D612	SB360L6508	DIODE		D905	MA167ATA	DIODE	
Q752	2SC3940AQSTA	TRANSISTOR	▲	D613	SB360L6508	DIODE		D906	MA167ATA	DIODE	
Q771	2SA1309ARTA	TRANSISTOR	▲	D614	RVD1SS133TA	DIODE		D921	RVD1SS133TA	DIODE	
Q772	2SA1309ARTA	TRANSISTOR	▲	D621	MA167ATA	DIODE		D923	RVD1SS133TA	DIODE	
Q773	2SB621ARTA	TRANSISTOR	▲	D622	MA167ATA	DIODE		D924	MTZJ3R9ATA	DIODE	
Q774	2SA1309ARTA	TRANSISTOR	▲	D623	MA167ATA	DIODE		D930	LN41YCPHL	DIODE	
Q775	2SA1309ARTA	TRANSISTOR	▲	D624	MA167ATA	DIODE		D1001	MTZJ10CTA	DIODE	▲
Q776	2SA1309ARTA	TRANSISTOR	▲	D625	MA167ATA	DIODE		D1002	MA700ATA	DIODE	
Q901	RVTDTTC114YST	TRANSISTOR		D626	MA167ATA	DIODE					
Q902	2SA933SSTA	TRANSISTOR		D627	MA167ATA	DIODE				VARIABLE RESISTORS	
Q908	RVTDTTC114YST	TRANSISTOR		D628	MA167ATA	DIODE					
Q1001	2SC3940AQSTA	TRANSISTOR	▲	D631	MA167ATA	DIODE		VR501	EUWMR0026B15	VR, VOLUME	
Q1081	2SA1309ARTA	TRANSISTOR		D632	MA167ATA	DIODE		VR502	EVJ02QF01G15	VR, BALANCE	
Q1151	2SD1915FTA	TRANSISTOR		D633	MA167ATA	DIODE		VR511	EVJYA1F01C15	VR, BASS	
		DIODES		D634	MA167ATA	DIODE		VR512	EVJYA1F01C15	VR, TREBLE	
				D635	MA167ATA	DIODE		VR1150	EVJ06LF06A15	VR, VAR. RESISTOR	[MAV]
				D636	MA167ATA	DIODE					
D1	SVC211SPA-AL	DIODE		D637	MA167ATA	DIODE				SWITCHES	
D2	SVC211SPA-AL	DIODE		D638	MA167ATA	DIODE					
D3	SVC211SPA-AL	DIODE		D654	RVD1SS133TA	DIODE		S301	RSP2D009-J	SW, TV / VCR2	
D101	MTZJ5R1BTA	DIODE		D655	RVD1SS133TA	DIODE		S946	EVQ21405R	SW, POWER	
D102	RVD1SS133TA	DIODE		D701	1N5402BM21	DIODE	▲	S947	EVQ21405R	SW, PHONO	
D301	RVD1SS133TA	DIODE		D702	1N5402BM21	DIODE	▲	S948	EVQ21405R	SW, MUTING	
D302	MTZJ5R6BTA	DIODE		D703	1N5402BM21	DIODE	▲	S950	EVQ21405R	SW, FM AUTO/MONO	
D303	MTZJ5R6BTA	DIODE	▲	D704	1N5402BM21	DIODE	▲	S951	EVQ21405R	SW, BAND	
D331	RVD1SS133TA	DIODE		D705	MTZJ6R2BTA	DIODE	▲	S952	EVQ21405R	SW, TUNING (-)	
D351	MTZJ5R6BTA	DIODE	▲	D706	MTZJ6R2BTA	DIODE	▲	S953	EVQ21405R	SW, TUNING (+)	
D352	MTZJ5R6BTA	DIODE	▲	D707	MTZJ30DTA	DIODE	▲	S954	EVQ21405R	SW, MEMORY	
D353	RVD1SS133TA	DIODE		D708	MTZJ15CTA	DIODE	▲	S956	EVQ21405R	SW, PRESET (-)	
D354	RVD1SS133TA	DIODE		D721	1N5402BM21	DIODE	▲	S957	EVQ21405R	SW, PRESET (+)	
D401	MTZJ7R5CTA	DIODE		D722	1N5402BM21	DIODE	▲	S958	EVQ21405R	SW, HELP/RESET	
D403	RVD1SS133TA	DIODE		D723	1N5402BM21	DIODE	▲	S960	EVQ21405R	SW, TUNER	
D404	RVD1SS133TA	DIODE		D724	1N5402BM21	DIODE	▲	S961	EVQ21405R	SW, CD	
D581	MTZJ3R0ATA	DIODE	[MAV]	D725	1N5402BM21	DIODE	▲	S962	EVQ21405R	SW, TAPE	
D582	MTZJ3R0ATA	DIODE	[MAV]	D726	1N5402BM21	DIODE	▲	S963	EVQ21405R	SW, TV/VCR2	
D583	MTZJ3R0ATA	DIODE	[MAV]	D727	1N5402BM21	DIODE	▲	S964	EVQ21405R	SW, VCR	
D584	MTZJ3R0ATA	DIODE	[MAV]	D728	1N5402BM21	DIODE	▲	S970	EVQ21405R	SW, SIMULATED	
D601	SB360L6508	DIODE		D751	1SR35200TB	DIODE	▲	S971	EVQ21405R	SW, THEATER	
D602	SB360L6508	DIODE		D752	1SR35200TB	DIODE	▲	S972	EVQ21405R	SW, LIVE	
D603	SB360L6508	DIODE		D753	1SR35200TB	DIODE	▲	S973	EVQ21405R	SW, CLUB	
D604	RVD1SS133TA	DIODE		D754	1SR35200TB	DIODE	▲	S974	EVQ21405R	SW, HALL	
D605	MTZJ6R2BTA	DIODE		D755	RVD1SS133TA	DIODE		S975	EVQ21405R	SW, VDP	
D606	RVD1SS133TA	DIODE		D756	MTZJ6R8BTA	DIODE	▲	S976	EVQ21405R	SW, DELAY	
D607	RVD1SS133TA	DIODE		D771	RVD1SS133TA	DIODE		S980	EVQ21405R	SW, SPEAKER A	
D608	RVD1SS133TA	DIODE		D772	MTZJ8R2BTA	DIODE	[M]	S981	EVQ21405R	SW, SPEAKER B	
D609	RVD1SS133TA	DIODE		D773	RVD1SS133TA	DIODE		S982	EVQ21405R	SW, LOUDNESS	
D610	RVD1SS133TA	DIODE		D901	1SS29ITA	DIODE		S983	EVQ21405R	SW, DPL/SFC/MODE	
D611	SB360L6508	DIODE		D903	MTZJ4R7BTA	DIODE		S984	EVQ21405R	SW, PROLOGIC	

Ref No	Part No.	Part Name & Description	Remarks	Ref No	Part No.	Part Name & Description	Remarks	Ref No	Part No.	Part Name & Description	Remarks
S985	EVQ21405R	SW, CENTER		L601	RLQYR73M	CHOKE COIL		F4	XBA1C80NBAL	FUSE	[MAV] ⚠
				L602	RLQYR73M	CHOKE COIL					
		CONNECTORS		L651	RLQYR73M	CHOKE COIL				FUSE CLIP	
				L652	RLQYR73M	CHOKE COIL					
CN101	RJU057W007	CONNECTOR (7 P)		L671	RLQYR73M	CHOKE COIL		FC701	RJR0169T	FUSE HOLDER	[M]
CN102	RJU057W007	CONNECTOR (7 P)		L751	RLQB101KTA-Y	CHOKE COIL		FC702	RJR0169T	FUSE HOLDER	[M]
CN351	RJS7T6ZA	CONNECTOR (7 P)		L901	RLQB101KTA-Y	CHOKE COIL		FC705	SJT388	FUSE HOLDER	
CN401	RJU100W07	CONNECTOR (7 P)	[MAV]	L1051	RLQB101KTA-Y	CHOKE COIL		FC706	SJT388	FUSE HOLDER	
CN402	RJU100W07	CONNECTOR (7 P)	[MAV]	T701	RTP1Q5C008-V	POWER TRANSFORMER	[MAV] ⚠	FC707	SJT388	FUSE HOLDER	
CN403	RJU100W07	CONNECTOR (7 P)	[MAV]	T751	RTP1H5C001-V	POWER TRANSFORMER	⚠	FC708	SJT388	FUSE HOLDER	
CN501	RJU100W07	CONNECTOR (7 P)	[MAV]								
CN502	RJU100W04	CONNECTOR (4 P)	[MAV]			COMP. COMBINATION				JACKS	
CN702	RJS1A6605	CONNECTOR (5 P)		Z101	RLA2Z002M-T	AM ANT. COIL					
CN751	SJS305-1	CONNECTOR (3 P)		Z102	RLI2Z006M-T	AM IFT		JK101	RJH4405	JK, ANT TERMINAL	
CN771	SJT3213	CONNECTOR (2 P)		Z751	ERZV10V511CS	ZNR	⚠	JK351	RJH2304N	JK, RCA TERMINAL	[MAV]
CN901	RJU003K008M1	CONNECTOR (8 P)		Z891	RCDS4242N	REMOTE SENSOR		JK352	SJFK5-1	JK, VCR IN	
CN902	RJU003K010M1	CONNECTOR (10P)						JK353	SJF3068-NJ	JK, RCA TERMINAL	[M]
CN903	RJU003K010M1	CONNECTOR (10P)				CERAMIC FILTERS		JK401	SJF3068-7N	JK, PHONE	
CN904	RJU003K008M1	CONNECTOR (8 P)		CF201	RLFFETMGD01L	CERAMIC FILTER		JK402	SJF3069N	JK, TAPE	
CN905	RJU003K008M1	CONNECTOR (8 P)		CF202	RLFFETMGD01L	CERAMIC FILTER		JK403	SJF3069N	JK, VDP/TV	
CN1001	RJU100W07	CONNECTOR (7 P)	[MAV]	CF901	RVBCST4R00MT	CERAMIC OSC		JK404	SJF3069N	JK, VCR1	
CN1002	RJU100W07	CONNECTOR (7 P)	[MAV]	CF1051	EF0EC8004T4	CERAMIC OSCILLATOR		JK405	SJFD7	JK, FM MULTI OUT	
CP101	RJT057W007-1	CONNECTOR (7 P)						JK406	SJF3068-7N	JK, RCA TERMINAL	
CP102	RJT057W007-1	CONNECTOR (7 P)				OSCILLATORS		JK601	RJH5601	JK, SP TERMINAL	
CP353	RJP3G4YA	CONNECTOR (3P)						JK602	RJH5601	JK, SP TERMINAL	
CP401	RJT100W07	CONNECTOR (7 P)	[MAV]	X101	RSXZ456KM07M	CERAMIC OSCILLATOR		JK603	RJR0054	JK, SP TERMINAL	
CP402	RJT100W07	CONNECTOR (7 P)	[MAV]	X102	RLFDGTD01H	FM RESONATOR		JK791	SJSD16-1	JK, AC INLET	⚠
CP403	RJT100W07	CONNECTOR (7 P)	[MAV]	X103	SVQ49U722T-S	CRYSTAL OSCILLATOR		JK792	RJS2A0102-1S	JK, AC OUTLET	⚠
CP501	RJT100W07	CONNECTOR (7 P)	[MAV]	X351	RSXC14M3S01	X*TAL		HP601	RJJ63TA01	JK, HEADPHONE	
CP502	RJT100W04	CONNECTOR (4 P)	[MAV]							EARTH TERMINALS	
CP701A	RJP6G4YA	CONNECTOR (6P)				RELAYS		E401	SNE1004-2	EARTH TERMINAL	
CP901	RJT003K008M1	CONNECTOR (8 P)		RL601	RSY0013M-0	24V RELAY		E601	SNE1004-2	EARTH TERMINAL	
CP902	RJT003K010M1	CONNECTOR (10P)		RL602	RSY0013M-0	24V RELAY					
CP903	RJT003K010M1	CONNECTOR (10P)		RL603	RSY0013M-0	24V RELAY				WIRES	
CP904	RJT003K008M1	CONNECTOR (8 P)		RL604	RSY0013M-0	24V RELAY					
CP905	RJT003K008M1	CONNECTOR (8 P)		RL751	RSY0019M-0	12V TV-5 RELAY	⚠	W1	REX0811	WIRE,FAN	[MAV]
CP1001	RJT100W07	CONNECTOR (7 P)	[MAV]	RL751	RSY0021-0	12V TV-8 RELAY	⚠ [MAV](PC)	W353	REX0800	SHIELD WIRE	[MAV]
CP1002	RJT100W07	CONNECTOR (7 P)	[MAV]								
		COILS, TRANSFORMERS									
L1	RLQZP1R2KT-Y	INDUCTOR				DISPLAY TUBE					
L2	RLQZPR47KT-Y	INDUCTOR		FL901	RSL0213-F	FL DISPLAY	[MAV]				
L101	ELESN1R5MA	CHOKE COIL									
L103	ELEXTR47MA9	CHOKE COIL				FUSES					
L351	RLQB101KTA-Y	CHOKE COIL		F1	XBA1C80NBAL	FUSE	[MAV] ⚠				
L352	ELEXT330KA9	CHOKE COIL		F3	XBA1C80NBAL	FUSE	[MAV] ⚠				
L501	RLQZP1R0KT-Y	AXIAL COIL									
L502	RLQZP1R0KT-Y	AXIAL COIL									

Resistors & Capacitors

Notes : * Important safety notice:

Components identified by Δ mark have special characteristics important for safety.

Furthermore, special parts which have purposes of fire-retardant (resistors), high-quality sound (capacitors), low-noise (resistors), etc. are used. When replacing any of components, be sure to use only manufacturer's specified parts shown in the parts list.

* Capacitor values are in microfarad (μ F) unless specified otherwise, P=Pico-farads (pF) F=Farads (F)

* Resistors values are in ohms, unless specified otherwise, 1k=1,000(OHM), 1M=1,000k(OHM)

Ref No	Part No.	Values & Remarks	Ref No	Part No.	Values & Remarks	Ref No	Part No.	Values & Remarks	Ref No	Part No.	Values & Remarks
	RESISTORS		R135	ERDS2TJ102T	1K 1/4W	R336	ERDS2TJ332T	3.3K 1/4W	R430	ERDS2TJ102T	1K 1/4W
			R136	ERDS2TJ102T	1K 1/4W	R337	ERDS2TJ332T	3.3K 1/4W	R431	ERDS2TJ224T	220K 1/4W
			R137	ERDS2TJ102T	1K 1/4W	R338	ERDS2TJ332T	3.3K 1/4W	R432	ERDS2TJ224T	220K 1/4W
R1	ERDS2TJ104T	100K 1/4W	R139	ERDS2TJ272T	2.7K 1/4W	R339	ERDS2TJ332T	3.3K 1/4W	R433	ERDS2TJ102T	1K 1/4W
R2	ERDS2TJ104T	100K 1/4W	R140	ERDS2TJ272T	2.7K 1/4W	R359	ERDS2TJ750T	75 1/4W	R434	ERDS2TJ102T	1K 1/4W
R3	ERDS2TJ221T	220 1/4W	R141	ERDS2TJ103T	10K 1/4W	R362	ERDS2TJ750T	75 1/4W	R435	ERDS2TJ473T	47K 1/4W
R4	ERDS2TJ104T	100K 1/4W	R142	ERDS2TJ103T	10K 1/4W	R367	ERDS2TJ102T	1K 1/4W	R440	ERDS1FVJ820T	82 1/2W Δ
R5	ERDS2TJ564T	560K 1/4W	R143	ERDS2TJ222T	2.2K 1/4W	R368	ERDS2TJ102T	1K 1/4W	R441	ERDS2TJ473T	47K 1/4W
R6	ERDS2TJ391T	390 1/4W	R144	ERDS2TJ222T	2.2K 1/4W	R369	ERDS2TJ182T	1.8K 1/4W	R442	ERDS2TJ473T	47K 1/4W
R7	ERDS2TJ272T	2.7K 1/4W	R145	ERDS2TJ102T	1K 1/4W	R370	ERDS2TJ182T	1.8K 1/4W	R443	ERDS2TJ330T	33 1/4W
R8	ERDS2TJ684T	680K 1/4W	R146	ERDS2TJ102T	1K 1/4W	R371	ERD2FCVG220T	22 1/4W	R451	ERDS2TJ224T	220K 1/4W
R9	ERDS2TJ391T	390 1/4W	R147	ERDS2TJ474T	470K 1/4W	R372	ERD2FCVG220T	22 1/4W	R452	ERDS2TJ224T	220K 1/4W
R10	ERDS2TJ391T	390 1/4W	R148	ERDS2TJ474T	470K 1/4W	R373	ERDS2TJ103T	10K 1/4W	R453	ERDS2TJ821T	820 1/4W
R11	ERDS2TJ684T	680K 1/4W	R149	ERDS2TJ680T	68 1/4W	R374	ERDS2TJ103T	10K 1/4W	R454	ERDS2TJ821T	820 1/4W
R103	ERDS2TJ151T	150 1/4W	R171	ERDS2TJ102T	1K 1/4W	R375	ERDS2TJ103T	10K 1/4W	R455	ERDS2TJ563T	56K 1/4W
R104	ERDS2TJ102T	1K 1/4W	R172	ERDS2TJ102T	1K 1/4W	R401	ERDS2TJ102T	1K 1/4W	R456	ERDS2TJ563T	56K 1/4W
R105	ERDS2TJ471T	470 1/4W	R173	ERDS2TJ471T	470 1/4W	R402	ERDS2TJ102T	1K 1/4W	R457	ERDS2TJ271T	270 1/4W
R106	ERDS2TJ224T	220K 1/4W	R175	ERDS2TJ102T	1K 1/4W	R405	ERDS2TJ102T	1K 1/4W	R458	ERDS2TJ271T	270 1/4W
R107	ERDS2TJ471T	470 1/4W	R176	ERDS2TJ391T	390 1/4W	R406	ERDS2TJ102T	1K 1/4W	R459	ERDS2TJ680T	68 1/4W
R110	ERDS2TJ102T	1K 1/4W	R301	ERDS2TJ820T	82 1/4W	R407	ERDS2TJ102T	1K 1/4W	R460	ERDS2TJ680T	68 1/4W
R112	ERDS2TJ104T	100K 1/4W	R302	ERDS2TJ820T	82 1/4W	R408	ERDS2TJ102T	1K 1/4W	R461	ERDS2TJ184T	180K 1/4W
R113	ERDS2TJ103T	10K 1/4W	R303	ERDS2TJ820T	82 1/4W	R409	ERDS2TJ102T	1K 1/4W	R462	ERDS2TJ184T	180K 1/4W
R114	ERDS2TJ562T	5.6K 1/4W	R304	ERDS2TJ820T	82 1/4W	R410	ERDS2TJ102T	1K 1/4W	R463	ERDS2TJ123T	12K 1/4W
R115	ERDS2TJ561T	560 1/4W	R307	ERDS2TJ104T	100K 1/4W	R411	ERDS2TJ102T	1K 1/4W	R464	ERDS2TJ123T	12K 1/4W
R116	ERDS2TJ102T	1K 1/4W	R308	ERDS2TJ472T	4.7K 1/4W	R412	ERDS2TJ102T	1K 1/4W	R465	ERDS2TJ563T	56K 1/4W
R117	ERDS2TJ104T	100K 1/4W	R309	ERDS2TJ392T	3.9K 1/4W	R413	ERDS2TJ102T	1K 1/4W	R466	ERDS2TJ563T	56K 1/4W
R118	ERDS2TJ562T	5.6K 1/4W	R310	ERDS2TJ471T	470 1/4W	R414	ERDS2TJ102T	1K 1/4W	R467	ERDS2TJ102T	1K 1/4W
R119	ERDS2TJ822T	8.2K 1/4W	R311	ERDS2TJ680T	68 1/4W	R415	ERDS2TJ102T	1K 1/4W	R468	ERDS2TJ102T	1K 1/4W
R120	ERDS2TJ473T	47K 1/4W	R314	ERDS2TJ221T	220 1/4W	R416	ERDS2TJ102T	1K 1/4W	R501	ERDS2TJ222T	2.2K 1/4W
R121	ERDS2TJ332T	3.3K 1/4W	R320	ERDS2TJ103T	10K 1/4W	R417	ERDS2TJ473T	47K 1/4W	R502	ERDS2TJ222T	2.2K 1/4W
R122	ERDS2TJ272T	2.7K 1/4W	R321	ERDS2TJ470T	47 1/4W	R418	ERDS2TJ473T	47K 1/4W	R503	ERDS2TJ103T	10K 1/4W
R124	ERDS2TJ271T	270 1/4W	R322	ERDS2TJ471T	470 1/4W	R419	ERDS2TJ104T	100K 1/4W	R504	ERDS2TJ103T	10K 1/4W
R125	ERDS2TJ472T	4.7K 1/4W	R324	ERDS2TJ103T	10K 1/4W	R420	ERDS2TJ104T	100K 1/4W	R505	ERDS2TJ103T	10K 1/4W
R126	ERDS2TJ472T	4.7K 1/4W	R325	ERDS1FVJ220T	22 1/2W Δ	R421	ERDS2TJ104T	100K 1/4W	R506	ERDS2TJ103T	10K 1/4W
R127	ERDS2TJ103T	10K 1/4W	R326	ERDS2TJ222T	2.2K 1/4W	R422	ERDS2TJ104T	100K 1/4W	R507	ERDS2TJ153T	15K 1/4W
R128	ERDS2TJ820T	82 1/4W	R327	ERDS1FVJ271T	270 1/2W Δ	R423	ERDS2TJ102T	1K 1/4W	R508	ERDS1FVJ2R2T	2.2 1/2W Δ
R129	ERDS2TJ473T	47K 1/4W	R328	ERDS2TJ222T	2.2K 1/4W	R424	ERDS2TJ102T	1K 1/4W	R511	ERDS2TJ471T	470 1/4W
R130	ERDS2TJ102T	1K 1/4W	R329	ERDS2TJ470T	47 1/4W	R425	ERDS2TJ103T	10K 1/4W	R512	ERDS2TJ471T	470 1/4W
R131	ERDS2TJ102T	1K 1/4W	R331	ERDS2TJ221T	220 1/4W	R426	ERDS2TJ103T	10K 1/4W	R513	ERDS2TJ474T	470K 1/4W
R132	ERDS2TJ103T	10K 1/4W	R332	ERDS2TJ104T	100K 1/4W	R427	ERDS2TJ103T	10K 1/4W	R514	ERDS2TJ474T	470K 1/4W
R133	ERDS2TJ102T	1K 1/4W	R333	ERDS2TJ101T	100 1/4W	R428	ERDS2TJ332T	3.3K 1/4W	R515	ERDS2TJ474T	470K 1/4W
R134	ERDS2TJ102T	1K 1/4W	R334	ERDS2TJ101T	100 1/4W	R429	ERDS2TJ102T	1K 1/4W	R516	ERDS2TJ474T	470K 1/4W

Ref No	Part No.	Values & Remarks	Ref No	Part No.	Values & Remarks	Ref No	Part No.	Values & Remarks	Ref No	Part No.	Values & Remarks
R517	ERDS2TJ332T	3.3K 1/4W	R569	ERDS2TJ102T	1K 1/4W	R622	ERD25FVJ680T	68 1/4W	R670	ERDS2TJ563T	56K 1/4W
R518	ERDS2TJ332T	3.3K 1/4W	R570	ERDS2TJ102T	1K 1/4W	R623	ERDS2TJ104T	100K 1/4W	R671	ERD25FVJ680T	68 1/4W
R519	ERDS2TJ182T	1.8K 1/4W	R571	ERDS2TJ222T	2.2K 1/4W	R624	ERDS2TJ563T	56K 1/4W	R672	ERD25FVJ680T	68 1/4W
R520	ERDS2TJ182T	1.8K 1/4W	R572	ERDS2TJ222T	2.2K 1/4W	R625	ERDS2TJ563T	56K 1/4W	R673	ERDS2TJ470T	47 1/4W
R521	ERDS2TJ223T	22K 1/4W	R573	ERDS2TJ102T	1K 1/4W	R626	ERDS2TJ473T	47K 1/4W	R674	ERDS1FVJ100T	10 1/2W
R522	ERDS2TJ223T	22K 1/4W	R574	ERDS2TJ102T	1K 1/4W	R627	ERDS2TJ824T	820K 1/4W	R675	ERDS2TJ102T	1K 1/4W
R523	ERDS2TJ392T	3.9K 1/4W	R575	ERDS2TJ102T	1K 1/4W	R628	ERDS2TJ223T	22K 1/4W	R676	ERD25FVJ151T	150 1/4W
R524	ERDS2TJ392T	3.9K 1/4W	R576	ERDS2TJ102T	1K 1/4W	R629	ERDS2TJ682T	6.8K 1/4W	R678	ERDS2TJ184T	180K 1/4W
R525	ERDS2TJ222T	2.2K 1/4W	R577	ERDS2TJ102T	1K 1/4W	R630	ERDS2TJ682T	6.8K 1/4W	R679	ERD25FVJ151T	150 1/4W
R526	ERDS2TJ222T	2.2K 1/4W	R578	ERDS2TJ102T	1K 1/4W	R631	ERDS2TJ123T	12K 1/4W	R680	ERDS2TJ221T	220 1/4W
R527	ERDS2TJ122T	1.2K 1/4W	R579	ERDS2TJ223T	22K 1/4W	R632	ERDS2TJ472T	4.7K 1/4W	R681	ERDS2TJ270T	27 1/4W
R528	ERDS2TJ122T	1.2K 1/4W	R580	ERDS2TJ102T	1K 1/4W	R633	ERDS2TJ123T	12K 1/4W	R682	ERDS2TJ270T	27 1/4W
R529	ERDS2TJ273T	27K 1/4W	R581	ERDS2TJ102T	1K 1/4W	R634	ERDS2TJ472T	4.7K 1/4W	R683	ERDS2TJ270T	27 1/4W
R530	ERDS2TJ273T	27K 1/4W	R582	ERDS2TJ102T	1K 1/4W	R635	ERD25FVJ151T	150 1/4W	R684	ERDS2TJ270T	27 1/4W
R531	ERDS2TJ102T	1K 1/4W	R583	ERDS2TJ102T	1K 1/4W	R636	ERD25FVJ151T	150 1/4W	R685	ERDS2TJ270T	27 1/4W
R532	ERDS2TJ102T	1K 1/4W	R584	ERDS2TJ102T	1K 1/4W	R637	ERG1SJ101E	100 1W	R686	ERDS2TJ270T	27 1/4W
R533	ERDS2TJ473T	47K 1/4W	R585	ERDS2TJ102T	1K 1/4W	R638	ERG1SJ101E	100 1W	R687	ERDS2TJ270T	27 1/4W
R534	ERDS2TJ473T	47K 1/4W	R586	ERDS2TJ102T	1K 1/4W	R639	ERG1SJ101E	100 1W	R688	ERDS2TJ270T	27 1/4W
R535	ERDS2TJ392T	3.9K 1/4W	R587	ERDS2TJ102T	1K 1/4W	R640	ERG1SJ101E	100 1W	R689	ERDS2TJ270T	27 1/4W
R536	ERDS2TJ392T	3.9K 1/4W	R588	ERDS2TJ102T	1K 1/4W	R641	ERDS2TJ684T	680K 1/4W	R690	ERDS2TJ270T	27 1/4W
R537	ERDS2TJ103T	10K 1/4W	R589	ERDS2TJ472T	4.7K 1/4W	R642	ERDS2TJ682T	6.8K 1/4W	R691	ERDS2TJ270T	27 1/4W
R538	ERDS2TJ103T	10K 1/4W	R590	ERDS2TJ473T	47K 1/4W	R643	ERDS2TJ682T	6.8K 1/4W	R692	ERDS2TJ270T	27 1/4W
R539	ERDS2TJ272T	2.7K 1/4W	R591	ERDS2TJ222T	2.2K 1/4W	R644	ERDS2TJ222T	2.2K 1/4W	R693	ERDS2TJ270T	27 1/4W
R540	ERDS2TJ272T	2.7K 1/4W	R592	ERDS2TJ222T	2.2K 1/4W	R645	ERD2FCVCG220T	22 1/4W	R694	ERDS2TJ270T	27 1/4W
R541	ERDS2TJ332T	3.3K 1/4W	R593	ERDS2TJ271T	270 1/4W	R646	ERD2FCVCG220T	22 1/4W	R695	ERDS2TJ102T	1K 1/4W
R542	ERDS2TJ332T	3.3K 1/4W	R594	ERDS2TJ103T	10K 1/4W	R647	ERDS2TJ221T	220 1/4W	R696	ERDS2TJ102T	1K 1/4W
R543	ERDS2TJ102T	1K 1/4W	R595	ERDS2TJ333T	33K 1/4W	R648	ERDS2TJ221T	220 1/4W	R697	ERDS2TJ221T	220 1/4W
R544	ERDS2TJ102T	1K 1/4W	R601	ERDS2TJ102T	1K 1/4W	R649	ERD25FVJ680T	68 1/4W	R698	ERDS2TJ221T	220 1/4W
R545	ERDS2TJ684T	680K 1/4W	R602	ERDS2TJ102T	1K 1/4W	R650	ERD25FVJ680T	68 1/4W	R699	ERDS2TJ332T	3.3K 1/4W
R546	ERDS2TJ332T	3.3K 1/4W	R603	ERDS2TJ563T	56K 1/4W	R651	ERDS2TJ102T	1K 1/4W	R703	ERDS1FVJ3R9T	3.9 1/2W
R547	ERDS2TJ103T	10K 1/4W	R604	ERDS2TJ563T	56K 1/4W	R652	ERDS2TJ102T	1K 1/4W	R704	ERDS1FVJ3R9T	3.9 1/2W
R548	ERDS2TJ392T	3.9K 1/4W	R605	ERDS2TJ182T	1.8K 1/4W	R653	ERDS2TJ563T	56K 1/4W	R705	ERDS2TJ472T	4.7K 1/4W
R549	ERDS2TJ222T	2.2K 1/4W	R606	ERDS2TJ182T	1.8K 1/4W	R654	ERDS2TJ563T	56K 1/4W	R706	ERDS2TJ102T	1K 1/4W
R551	ERDS2TJ102T	1K 1/4W	R607	ERDS2TJ563T	56K 1/4W	R655	ERDS2TJ182T	1.8K 1/4W	R709	ERD25FVJ221T	220 1/4W
R552	ERDS2TJ102T	1K 1/4W	R608	ERDS2TJ563T	56K 1/4W	R656	ERDS2TJ182T	1.8K 1/4W	R712	ERDS2TJ472T	4.7K 1/4W
R553	ERDS2TJ104T	100K 1/4W	R609	ERDS2TJ470T	47 1/4W	R657	ERDS2TJ563T	56K 1/4W	R713	ERDS2TJ1R5T	1.5 1/4W
R554	ERDS2TJ104T	100K 1/4W	R610	ERDS2TJ470T	47 1/4W	R658	ERDS2TJ563T	56K 1/4W	R714	ERDS2TJ1R5T	1.5 1/4W
R555	ERDS2TJ223T	22K 1/4W	R611	ERDS1FVJ100T	10 1/2W	R659	ERDS2TJ470T	47 1/4W	R715	ERDS2TJ752T	7.5K 1/4W
R556	ERDS2TJ223T	22K 1/4W	R612	ERDS1FVJ100T	10 1/2W	R660	ERDS2TJ470T	47 1/4W	R716	ERDS2TJ682T	6.8K 1/4W
R557	ERDS2TJ471T	470 1/4W	R613	ERDS2TJ102T	1K 1/4W	R661	ERDS1FVJ100T	10 1/2W	R718	ERDS2TJ182T	1.8K 1/4W
R558	ERDS2TJ471T	470 1/4W	R614	ERDS2TJ102T	1K 1/4W	R662	ERDS1FVJ100T	10 1/2W	R721	ERDS1FVJ100T	10 1/2W
R559	ERDS2TJ222T	2.2K 1/4W	R615	ERDS2TJ184T	180K 1/4W	R663	ERDS2TJ102T	1K 1/4W	R722	ERDS1FVJ331T	330 1/2W
R560	ERDS2TJ222T	2.2K 1/4W	R616	ERDS2TJ154T	150K 1/4W	R664	ERDS2TJ102T	1K 1/4W	R723	ERDS2TJ472T	4.7K 1/4W
R561	ERDS2TJ272T	2.7K 1/4W	R617	ERDS2TJ473T	47K 1/4W	R665	ERDS2TJ184T	180K 1/4W	R724	ERDS1FVJ100T	10 1/2W
R562	ERDS2TJ272T	2.7K 1/4W	R618	ERDS2TJ473T	47K 1/4W	R666	ERDS2TJ154T	150K 1/4W	R725	ERDS2TJ122T	1.2K 1/4W
R564	ERDS2TJ332T	3.3K 1/4W	R619	ERDS2TJ223T	22K 1/4W	R667	ERDS2TJ102T	1K 1/4W	R727	ERDS1FVJ4R7T	4.7 1/2W
R565	ERDS2TJ102T	1K 1/4W	R620	ERD25FVJ220T	22 1/4W	R668	ERDS2TJ563T	56K 1/4W	R730	ERDS1FVJ681T	680 1/2W
R566	ERDS2TJ102T	1K 1/4W	R621	ERD25FVJ680T	68 1/4W	R669	ERDS2TJ182T	1.8K 1/4W	R731	ERDS1FVJ331T	330 1/2W

Ref No	Part No.	Values & Remarks	Ref No	Part No.	Values & Remarks	Ref No	Part No.	Values & Remarks	Ref No	Part No.	Values & Remarks
R732	ERDS1FVJ150T	15 1/2W	R943	ERDS2TJ102T	1K 1/4W	R1053	ERDS2TJ102T	1K 1/4W	C115	ECEA1EKA4R7B	4.7 25V
R741	ERDS1FVJ3R9T	3.9 1/2W	R946	ERDS2TJ103T	10K 1/4W	R1055	ERDS2TJ224T	220K 1/4W	C116	ECBT1C822MS5	8200P 16V
R742	ERDS1FVJ3R9T	3.9 1/2W	R947	ERDS2TJ103T	10K 1/4W	R1056	ERDS2TJ153T	15K 1/4W	C117	ECQB1H821JF3	820P 50V
R743	ERDS1FVJ3R9T	3.9 1/2W	R948	ERDS2TJ103T	10K 1/4W	R1061	ERDS2TJ222T	2.2K 1/4W	C118	ECFR1E183KR	0.018 25V
R744	ERDS1FVJ3R9T	3.9 1/2W	R949	ERDS2TJ103T	10K 1/4W	R1062	ERDS2TJ273T	27K 1/4W	C119	ECFR1E183KR	0.018 25V
R745	ERDS1FVJ3R9T	3.9 1/2W	R950	ERDS2TJ102T	1K 1/4W	R1063	ERDS2TJ332T	3.3K 1/4W	C120	ECEA1HKA010B	1 50V
R751	ERC12ZGK335D	3.3M 1/2W	R951	ERDS2TJ122T	1.2K 1/4W	R1081	ERDS2TJ104T	100K 1/4W	C121	ECEA1HKA010B	1 50V
R754	ERDS2TJ102T	1K 1/4W	R952	ERDS2TJ152T	1.5K 1/4W	R1082	ERDS2TJ474T	470K 1/4W	C122	ECEA1HKA2R2B	2.2 50V
R772	ERDS2TJ104T	100K 1/4W	R953	ERDS2TJ182T	1.8K 1/4W	R1151	ERDS2TJ473T	47K 1/4W	C123	ECEA1HKA010B	1 50V
R773	ERDS2TJ103T	10K 1/4W	R954	ERDS2TJ222T	2.2K 1/4W	R1152	ERDS2TJ473T	47K 1/4W	C124	ECBT1H102KB5	1000P 50V
R774	ERDS2TJ223T	22K 1/4W	R955	ERDS2TJ332T	3.3K 1/4W	R1153	ERDS2TJ223T	22K 1/4W	C125	ECBT1H150JC5	15P 50V
R775	ERDS2TJ472T	4.7K 1/4W	R956	ERDS2TJ472T	4.7K 1/4W	R1154	ERDS2TJ473T	47K 1/4W	C126	ECBT1H104ZF5	0.1 50V
R777	ERDS2TJ150T	15 1/4W	R957	ERDS2TJ682T	6.8K 1/4W	R1155	ERDS2TJ393T	39K 1/4W	C127	ECEA1CKA220B	22 16V
R778	ERDS2TJ222T	2.2K 1/4W	R958	ERDS2TJ123T	12K 1/4W	R1156	ERDS2TJ393T	39K 1/4W	C128	ECBT1C103NS5	0.01 16V
R779	ERDS2TJ103T	10K 1/4W	R960	ERDS2TJ102T	1K 1/4W	R1157	ERDS2TJ222T	2.2K 1/4W	C129	ECEA0JKA101B	100 6.3V
R780	ERDS2TJ473T	47K 1/4W	R961	ERDS2TJ122T	1.2K 1/4W	R1158	ERDS2TJ104T	100K 1/4W	C130	ECEA0JKA101B	100 6.3V
R781	ERDS2TJ473T	47K 1/4W	R962	ERDS2TJ152T	1.5K 1/4W	R1159	ERDS2TJ103T	10K 1/4W	C131	ECBT1C103NS5	0.01 16V
R782	ERDS2TJ153T	15K 1/4W	R963	ERDS2TJ182T	1.8K 1/4W	R1160	ERDS2TJ104T	100K 1/4W	C132	ECBT1H102KB5	1000P 50V
R783	ERDS2TJ103T	10K 1/4W	R964	ERDS2TJ222T	2.2K 1/4W	R1161	ERDS2TJ104T	100K 1/4W	C133	ECBT1H150JC5	15P 50V
R784	ERDS2TJ335T	3.3M 1/4W	R970	ERDS2TJ102T	1K 1/4W	R1163	ERDS2TJ333T	33K 1/4W	C134	ECBT1H180JC5	18P 50V
R791	ERDS2TJ223T	22K 1/4W	R971	ERDS2TJ122T	1.2K 1/4W	R1164	ERDS2TJ393T	39K 1/4W	C137	ECBT1H271KB5	270P 50V
R792	ERDS2TJ223T	22K 1/4W	R972	ERDS2TJ152T	1.5K 1/4W				C138	ECBT1H271KB5	270P 50V
R793	ERDS2TJ223T	22K 1/4W	R973	ERDS2TJ182T	1.8K 1/4W		CAPACITORS		C141	ECEA1HKA010B	1 50V
R794	ERDS2TJ223T	22K 1/4W	R974	ERDS2TJ222T	2.2K 1/4W				C142	ECEA1HKA010B	1 50V
R795	ERDS2TJ222T	2.2K 1/4W	R975	ERDS2TJ332T	3.3K 1/4W	C1	ECBT1H5R6KC5	5.6P 50V	C143	ECEA1HKA010B	1 50V
R796	ERDS2TJ223T	22K 1/4W	R976	ERDS2TJ472T	4.7K 1/4W	C2	RCBS1H102KB5	1000P 50V	C144	ECEA1HKA010B	1 50V
R797	ERDS2TJ682T	6.8K 1/4W	R980	ERDS2TJ102T	1K 1/4W	C3	ECBT1H2R2KC5	2.2P 50V	C145	ECBT1H220JC5	22P 50V
R798	ERDS2TJ223T	22K 1/4W	R981	ERDS2TJ122T	1.2K 1/4W	C4	ECBT1H181KB5	180P 50V	C146	ECBT1H331KB5	330P 50V
R901	ERDS2TJ102T	1K 1/4W	R982	ERDS2TJ152T	1.5K 1/4W	C5	ECBT1H5R6KC5	5.6P 50V	C147	ECBT1H102KB5	1000P 50V
R906	ERDS2TJ104T	100K 1/4W	R983	ERDS2TJ182T	1.8K 1/4W	C6	ECBT1H3R3KC5	3.3P 50V	C148	ECBT1C103NS5	0.01 16V
R907	ERDS2TJ104T	100K 1/4W	R984	ERDS2TJ222T	2.2K 1/4W	C7	ECBT1H4R7KC5	4.7P 50V	C149	ECBT1C103NS5	0.01 16V
R908	ERDS2TJ104T	100K 1/4W	R985	ERDS2TJ822T	8.2K 1/4W	C8	ECBT1H3R3KC5	3.3P 50V	C150	ECBT1H104ZF5	0.1 50V
R909	ERDS2TJ104T	100K 1/4W	R990	ERDS2TJ153T	15K 1/4W	C9	ECBT1H2R2KC5	2.2P 50V	C172	ECBT1H331KB5	330P 50V
R910	ERDS2TJ102T	1K 1/4W	R1001	ERDS2TJ102T	1K 1/4W	C10	ECBT1H180JC5	18P 50V	C173	ECEA1CKA220B	22 16V
R911	ERDS2TJ104T	100K 1/4W	R1002	ERDS2TJ102T	1K 1/4W	C11	RCBS1H102KB5	1000P 50V	C174	ECEA1CKA100B	10 16V
R912	ERDS2TJ103T	10K 1/4W	R1003	ERDS2TJ102T	1K 1/4W	C101	ECBT1C103NS5	0.01 16V	C175	ECBT1C103NS5	0.01 16V
R913	ERDS2TJ103T	10K 1/4W	R1004	ERDS2TJ102T	1K 1/4W	C103	ECBT1C103NS5	0.01 16V	C196	ECBT1H102KB5	1000P 50V
R914	ERDS2TJ274T	270K 1/4W	R1005	ERDS2TJ203T	20K 1/4W	C104	ECBT1H102KB5	1000P 50V	C301	ECEA1HKA3R3B	3.3 50V
R917	ERDS2TJ103T	10K 1/4W	R1007	ERDS2TJ473T	47K 1/4W	C105	ECBT1H102KB5	1000P 50V	C302	ECEA0JU330B	33 6.3V
R920	ERDS2TJ271T	270 1/4W	R1008	ERDS2TJ473T	47K 1/4W	C106	ECBT1C103NS5	0.01 16V	C304	ECBT1H470J5	47P 50V
R921	ERDS2TJ121T	120 1/4W	R1009	ERDS2TJ332T	3.3K 1/4W	C107	ECBT1H473ZF5	0.047 50V	C305	ECEA0JU471B	470 6.3V
R922	ERDS2TJ472T	4.7K 1/4W	R1010	ERDS2TJ332T	3.3K 1/4W	C108	ECBT1H8R2KC5	8.2P 50V	C306	ECEA1CU100B	10 16V
R923	ERDS2TJ104T	100K 1/4W	R1011	ERDS2TJ332T	3.3K 1/4W	C109	ECBT1C103NS5	0.01 16V	C307	ECBT1E103ZF5	0.01 25V
R928	ERDS2TJ151T	150 1/4W	R1012	ERDS2TJ102T	1K 1/4W	C110	ECBT1C103NS5	0.01 16V	C308	ECEA0JU101B	100 6.3V
R929	ERDS2TJ101T	100 1/4W	R1013	ERDS2TJ103T	10K 1/4W	C111	ECEA1EKA4R7B	4.7 25V	C309	ECEA0JU101B	100 6.3V
R930	ERDS2TJ101T	100 1/4W	R1014	ERDS2TJ104T	100K 1/4W	C112	ECBT1C103NS5	0.01 16V	C310	ECBT1E103ZF5	0.01 25V
R936	ERDS2TJ102T	1K 1/4W	R1051	ERDS2TJ393T	39K 1/4W	C113	ECBT1H102KB5	1000P 50V	C329	ECBT1H470J5	47P 50V
R937	ERDS2TJ102T	1K 1/4W	R1052	ERDS2TJ105T	1M 1/4W	C114	ECEA1HKA3R3B	3.3 50V	C330	ECBT1H470J5	47P 50V

Ref No	Part No.	Values & Remarks	Ref No	Part No.	Values & Remarks	Ref No	Part No.	Values & Remarks	Ref No	Part No.	Values & Remarks
C331	ECBT1C122KR5	1200P 16V	C459	ECFR1E223KR	0.022 25V	C555	ECBT1H221KB5	220P 50V	C663	ECBT1H681KB5	680P 50V
C332	ECEA1HKA010B	1 50V	C460	ECFR1E223KR	0.022 25V	C556	ECBT1H221KB5	220P 50V	C664	ECBT1H681KB5	680P 50V
C333	ECEA1HKA010B	1 50V	C461	ECFR1E682KR	6800P 25V	C557	ECBT1E103ZF5	0.01 25V	C667	ECEA1HN3R3SB	3.3 50V
C334	ECBT1H220JU5	27P 50V	C462	ECFR1E682KR	6800P 25V	C558	ECBT1E103ZF5	0.01 25V	C668	ECBT1H681KB5	680P 50V
C335	ECBT1H220GC5	22P 50V	C463	ECEA1HU4R7B	4.7 50V	C559	ECEA1CKA100B	10 16V	C669	ECEA1JU330	33 63V
C336	ECBT1H220JC5	22P 50V	C464	ECEA1HU4R7B	4.7 50V	C560	ECEA1CKA100B	10 16V	C670	ECCR1H100K5	10P 50V
C337	ECBT1H220JC5	22P 50V	C465	ECBT1E103ZF5	0.01 25V	C563	ECBT1H104ZF5	0.1 50V	C671	ECEA2AU100B	10 100V
C338	ECBT1H101KB5	100P 50V	C466	ECBT1E103ZF5	0.01 25V	C581	ECEA0JKA101B	100 6.3V	C672	ECEA2AU100B	10 100V
C339	ECBT1H101KB5	100P 50V	C501	ECFR1E333KR	0.033 25V	C582	ECEA0JKA101B	100 6.3V	C674	ECQV1H473JZ3	0.047 50V
C340	ECBT1H101KB5	100P 50V	C502	ECFR1E333KR	0.033 25V	C583	ECEA0JKA101B	100 6.3V	C675	ECBT1H681KB5	680P 50V
C341	ECEA0JU101B	100 6.3V	C503	ECEA0JKA101B	100 6.3V	C584	ECEA0JKA101B	100 6.3V	C680	ECBT1H221KB5	220P 50V
C342	ECBT1E103ZF5	0.01 25V	C504	ECEA0JKA101B	100 6.3V	C601	ECEA1HN3R3SB	3.3 50V	C681	ECEA1HN100SB	10 50V
C351	ECEA0JKA101B	100 6.3V	C505	ECFR1C104MR	0.1 16V	C602	ECEA1HN3R3SB	3.3 50V	C682	ECEA1HN100SB	10 50V
C352	ECEA0JKA101B	100 6.3V	C506	ECFR1C104MR	0.1 16V	C603	ECBT1H681KB5	680P 50V	C685	ECBT1E103ZF5	0.01 25V
C354	ECBT1H104ZF5	0.1 50V	C511	ECEA1HKA3R3B	3.3 50V	C604	ECBT1H681KB5	680P 50V	C701	ECBT1E103ZF5	0.01 25V
C355	ECBT1H104ZF5	0.1 50V	C512	ECEA1HKA3R3B	3.3 50V	C605	ECEA1JU330	33 63V	C702	ECQE2104KF3	4K 250V
C357	ECBT1E103ZF5	0.01 25V	C513	ECBT1H150J5	15P 50V	C606	ECEA1JU330	33 63V	C703	ECES1KV752UX▲	7500 100V[MAV]
C358	ECBT1E103ZF5	0.01 25V	C514	ECBT1H150J5	15P 50V	C607	ECCR1H100K5	10P 50V	C704	ECES1KV752UX▲	7500 100V[MAV]
C373	ECEA1CKA470B	47 16V	C515	ECBT1H221KB5	220P 50V	C608	ECCR1H100K5	10P 50V	C705	ECEA1HM332EV	3300 50V▲[M]
C374	ECEA1CKA470B	47 16V	C516	ECBT1H221KB5	220P 50V	C609	ECBT1H221KB5	220P 50V	C706	ECEA1HM332EV	3300 50V▲[M]
C375	ECEA1CKA470B	47 16V	C517	ECBT1H330J5	33P 50V	C610	ECBT1H221KB5	220P 50V	C707	ECA1VM101B	100 10V
C401	ECEA1VKA4R7B	4.7 10V	C518	ECBT1H330J5	33P 50V	C611	ECQV1H473JZ3	0.047 50V	C708	ECCR1H103ZF5	0.01 50V
C402	ECEA1VKA4R7B	4.7 10V	C519	ECEA1VKA4R7B	4.7 10V	C612	ECQV1H473JZ3	0.047 50V	C709	ECEA1CU330B	33 16V
C403	ECBT1E103ZF5	0.01 25V	C520	ECEA1VKA4R7B	4.7 10V	C613	ECBT1H681KB5	680P 50V	C710	ECBT1E103ZF5	0.01 25V
C404	ECBT1E103ZF5	0.01 25V	C521	ECEA1VKA4R7B	4.7 10V	C614	ECBT1H681KB5	680P 50V	C711	ECCR1H103ZF5	0.01 50V
C405	ECBT1H101KB5	100P 50V	C522	ECEA1VKA4R7B	4.7 10V	C615	ECEA1JU330	33 63V	C712	ECEA1HU100B	10 50V
C406	ECBT1H101KB5	100P 50V	C523	ECFR1E123KR	0.012 25V	C616	ECEA2AU100B	10 100V	C713	ECCR1H103ZF5	0.01 50V
C409	ECEA1EU220B	22 25V	C524	ECFR1E123KR	0.012 25V	C617	ECEA1JU220B	22 63V	C714	ECEA1EU470B	47 25V
C410	ECEA1EU220B	22 25V	C525	ECQV1H683JZ3	0.068 50V	C618	ECEA2AN2R25B	2.2 100V	C715	ECEA1CU101B	100 16V
C411	ECBT1H101KB5	100P 50V	C526	ECQV1H683JZ3	0.068 50V	C619	ECBT1H102KB5	1000P 50V	C721	ECQE2104KF3	4K 400V
C412	ECBT1H101KB5	100P 50V	C527	ECBT1C562KR5	5600P 16V	C621	ECEA2AU100B	10 100V	C722	ECQE2104KF3	4K 250V
C413	ECEA1CU100B	10 16V	C528	ECBT1C562KR5	5600P 16V	C622	ECEA2AU100B	10 100V	C751	ECKWNS102MBM	02 400V
C414	ECEA1CU100B	10 16V	C529	ECQB1H273JF3	0.027 50V	C639	ECCR1H122KB5	1200P 50V	C752	ECCR1H103ZF5	0.01 50V
C415	ECBT1E103ZF5	0.01 25V	C530	ECQB1H273JF3	0.027 50V	C640	ECCR1H122KB5	1200P 50V	C753	ECA1EM102B	1000 25V▲
C416	ECBT1E103ZF5	0.01 25V	C531	ECBT1E103ZF5	0.01 25V	C649	ECEA2AU100B	10 100V	C754	ECBT1E103ZF5	0.01 25V
C429	ECBT1H101KB5	100P 50V	C532	ECBT1E103ZF5	0.01 25V	C650	ECEA2AU100B	10 100V	C755	ECEA1CKA470B	47 16V
C430	ECBT1H101KB5	100P 50V	C533	ECEA1EKA100B	10 25V	C651	ECEA1HN3R3SB	3.3 50V	C758	ECEA1AU101B	100 10V
C431	ECEA1CU100B	10 16V	C534	ECEA1EKA100B	10 25V	C652	ECEA1HN3R3SB	3.3 50V	C771	ECEA1HKA2R2B	2.2 50V
C432	ECEA1CU100B	10 16V	C536	ECBT1E103ZF5	0.01 25V	C653	ECBT1H681KB5	680P 50V	C772	ECEA1CU100B	10 16V
C440	ECBT1E103ZF5	0.01 25V	C537	ECEA1CU100B	10 16V	C654	ECBT1H681KB5	680P 50V	C773	ECBT1E223ZF5	0.022 25V
C451	ECEA1HU4R7B	4.7 50V	C538	ECEA1CU100B	10 16V	C655	ECEA1JU330	33 63V	C774	ECEA0JU221B	220 6.3V
C452	ECEA1HU4R7B	4.7 50V	C539	ECEA1CU100B	10 16V	C656	ECEA1JU330	33 63V	C901	ECEA0JU102B	1000 6.3V
C453	ECBT1H101KB5	100P 50V	C541	ECEA1HU470B	47 50V	C657	ECCR1H100K5	10P 50V	C902	ECBT1H104ZF5	0.1 50V
C454	ECBT1H101KB5	100P 50V	C542	ECEA1HU470B	47 50V	C658	ECCR1H100K5	10P 50V	C903	ECBT1E103ZF5	0.01 25V
C455	ECBT1H102KB5	1000P 50V	C551	ECEA1HKA3R3B	3.3 50V	C659	ECBT1H221KB5	220P 50V	C904	ECEA0JU102B	1000 6.3V
C456	ECBT1H102KB5	1000P 50V	C552	ECEA1HKA3R3B	3.3 50V	C660	ECBT1H221KB5	220P 50V	C906	ECEA0JKA101B	100 6.3V
C457	ECEA1AKA330B	33 10V	C553	ECBT1H101KB5	100P 50V	C661	ECQV1H473JZ3	0.047 50V	C908	ECBT1E103ZF5	0.01 25V
C458	ECEA1AKA330B	33 10V	C554	ECBT1H101KB5	100P 50V	C662	ECQV1H473JZ3	0.047 50V	C909	ECEA1HKA220B	22 50V

Ref No	Part No.	Values & Remarks	Ref No	Part No.	Values & Remarks	Ref No	Part No.	Values & Remarks	Ref No	Part No.	Values & Remarks
C910	ECEA1HKA220B	22 50V	C955	ECBT1H101KB5	100P 50V	C1025	ECEA1HKA3R3B	3.3 50V	C1057	ECFR1E152KR	1500P 25V
C911	ECEA1HKA220B	22 50V	C956	ECBT1H101KB5	100P 50V	C1026	ECEA1HKAR15B	0.15 50V	C1058	ECFR1E563KR	0.056 25V
C912	ECEA1HKA220B	22 50V	C1001	ECEA1HKA010B	1 50V	C1027	ECEA1HKA4R7B	4.7 50V	C1059	ECEA1CKA101B	100 16V
C913	ECEA1VKA100B	10 10V	C1002	ECEA1HKA010B	1 50V	C1028	ECEA1HKAR47B	0.47 50V	C1060	ECBT1E223ZF5	0.022 25V
C914	ECEA1VKA100B	10 10V	C1003	ECEA1HKA3R3B	3.3 50V	C1029	ECEA1HKA4R7B	4.7 50V	C1062	ECBT1E223ZF5	0.022 25V
C916	ECEA1HKA010B	1 50V	C1004	ECEA1HKA3R3B	3.3 50V	C1030	ECEA1HKAR47B	0.47 50V	C1063	ECEA1CKA101B	100 16V
C919	ECBT1E103ZF5	0.01 25V	C1005	ECEA1HKA010B	1 50V	C1031	ECQV1H104JZ3	0.1 50V	C1064	ECEA1HKA010B	1 50V
C920	ECEA1HKA010B	1 50V	C1007	ECFR1E223KR	0.022 25V	C1032	ECQV1H104JZ3	0.1 50V	C1065	ECBT1H681KB5	680P 50V
C921	ECBT1H331KB5	330P 50V	C1008	ECFR1E473KR	0.047 25V	C1033	ECEA0JKA470B	47 6.3V	C1067	ECBT1C152KR5	1500P 16V
C922	ECBT1H331KB5	330P 50V	C1009	ECEA0JU221B	220 6.3V	C1034	ECQV1H474JZ3	0.47 50V	C1068	ECBT1C152KR5	1500P 16V
C923	ECBT1H331KB5	330P 50V	C1010	ECEA1CKA100B	10 16V	C1035	ECBT1H681KB5	680P 50V	C1081	ECEA1HKA010B	1 50V
C924	ECBT1H331KB5	330P 50V	C1011	ECEA1CKA100B	10 16V	C1036	ECBT1H101KB5	100P 50V	C1082	ECBT1E223ZF5	0.022 25V
C925	ECBT1H331KB5	330P 50V	C1012	ECEA1CKA100B	10 16V	C1037	ECBT1H101KB5	100P 50V	C1151	ECEA1HKA010B	1 50V
C926	ECBT1H331KB5	330P 50V	C1013	ECEA1CKA100B	10 16V	C1038	ECBT1H101KB5	100P 50V	C1152	ECFR1C393KR	0.039 16V
C927	ECBT1H331KB5	330P 50V	C1014	ECEA0JU221B	220 6.3V	C1039	ECEA1CU101B	100 16V	C1153	ECFR1C393KR	0.039 16V
C928	ECBT1H331KB5	330P 50V	C1015	ECQV1H104JZ3	0.1 50V	C1040	ECEA1CKA100B	10 16V	C1154	ECEA1VKA4R7B	4.7 10V
C929	ECBT1H331KB5	330P 50V	C1016	ECQV1H104JZ3	0.1 50V	C1041	ECBT1E103ZF5	0.01 25V	C1155	ECBT1E103ZF5	0.01 25V
C930	ECBT1H331KB5	330P 50V	C1017	ECEA1HKAR47B	0.47 50V	C1043	ECEA1CKA100B	10 16V	C1156	ECBT1E103ZF5	0.01 25V
C932	ECBT1E103ZF5	0.01 25V	C1018	ECEA1HKA4R7B	4.7 50V	C1044	ECEA1CKA100B	10 16V	C1157	ECBT1E103ZF5	0.01 25V
C934	ECBT1H101KB5	100P 50V	C1019	ECEA1HKAR47B	0.47 50V	C1051	ECEA1HKA2R2B	2.2 50V	C1159	ECEA1HKA010B	1 50V
C941	ECBT1E103ZF5	0.01 25V	C1020	ECEA1HKA4R7B	4.7 50V	C1052	ECEA1HKA010B	1 50V	C1160	ECEA1HKA010B	1 50V
C948	ECBT1E103ZF5	0.01 25V	C1021	ECEA1HKAR15B	0.15 50V	C1053	ECEA1HKA3R3B	3.3 50V	C1161	ECBT1H101KB5	100P 50V
C949	ECBT1H101KB5	100P 50V	C1022	ECEA1HKA3R3B	3.3 50V	C1054	ECEA0JU221B	220 6.3V			
C951	ECBT1H101KB5	100P 50V	C1023	ECQV1H154JZ3	0.15 50V	C1055	ECEA1HKA010B	1 50V			
C954	ECBT1E103ZF5	0.01 25V	C1024	ECQV1H154JZ3	0.15 50V	C1056	ECFR1E563KR	0.056 25V			

■ Packaging

Notes: * Important safety notice :

Components identified by Δ mark have special characteristics important for safety.

Furthermore, special parts which have purposes of fire-retardant (resistors), high-quality sound (capacitors), low-noise (resistors), etc. are used. When replacing any of components, be sure to use only manufacturer's specified parts shown in the parts list.

* The parenthesized in the Remarks columns specify the areas. (Refer to the cover page for area.)
Parts without these indication can be used for all areas.

* [M] in Remarks column indicates parts that are supplied by **MESA**.

* [MAV] in Remarks column indicates parts that are supplied by **MAV**.

* Remote Control Unit : Supply period for three years from terminal of production.

* The "(SF)" mark denotes the standard part.

Ref No	Part No.	Part Name & Description	Remarks	Ref No	Part No.	Part Name & Description	Remarks	Ref No	Part No.	Part Name & Description	Remarks
		PACKING MATERIALS						A3	SJA172	AC CORD	(SF) Δ
						ACCESSORIES		A4	RSA0006	FM ANT	
P1	SPSD152	ACCESSORY BOX						A5	RFKSEX900PK	INSTRUMNLASS'Y	[MAV] (P)
P2	RPG2919	PACKING CASE	[MAV]	A1	RAK-SA606MHP	REMOTE CONTROL	[MAV]	A5	RFKSEX900PCK	INSTRUMNLASS'Y	[MAV] (PC)
P3	RPN0966	POLY FOAM	[MAV]	A1-1	RKK0020	REMOTE BATTY COVER		A6	SPB1061	VINYL BAG	
P4	RPFEX0005	MIRAMAT SHEET	[M]	A2	RSA0010	AM LOOP ANT					