

73

# STEREO RECEIVER R-70/R-70M

## SERVICE MANUAL

### FRONT PANEL

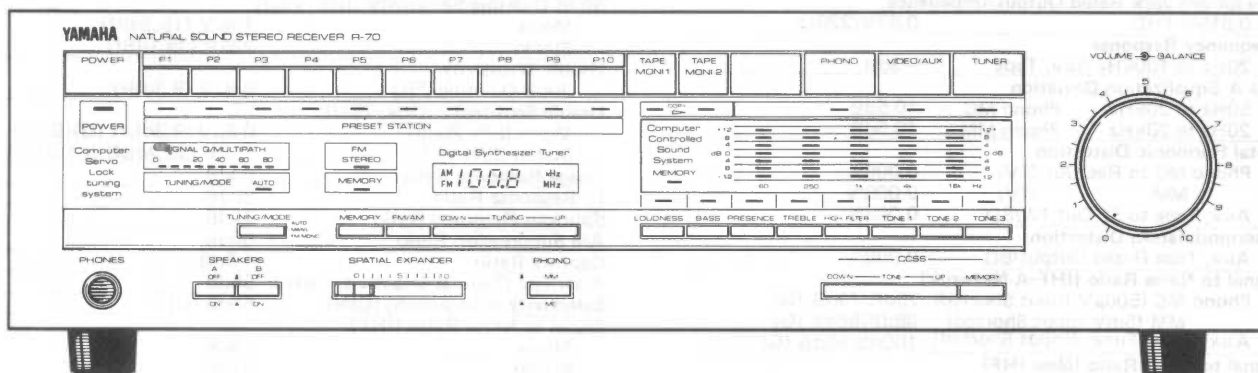

### CONTENTS

SPECIFICATIONS .....	1
TO SERVICE PERSONNEL .....	2
REAR PANEL .....	2
INTERNAL VIEW .....	3
DISASSEMBLY PROCEDURES .....	3
ADJUSTMENTS .....	4 ~ 6
PRINTED CIRCUIT BOARD .....	7 ~ 9
SCHEMATIC DIAGRAM .....	10
BLOCK DIAGRAM .....	10
PARTS LIST .....	11 ~ 21



# SPECIFICATIONS

## AUDIO SECTION

<b>Continuous Power Per Channel</b>			
20Hz to 20kHz, 0.015% THD		8Ω	45W
<b>Dynamic Power</b>			
1kHz IHF Signal		4Ω	80W
		2Ω	80W
<b>DIN Standard Output Power Per Channel</b>			
1kHz 1% THD		8Ω	55W (A)(B)(G)
<b>Dynamic Headroom (IHF)</b>			
8Ω			1.3dB
<b>Power Band Width</b>			
0.02% THD		22.5W	8Ω
		10Hz to 30kHz	
<b>Damping Factor</b>			
1kHz		8Ω	40
<b>Input Sensitivity/Impedance</b>			
Phono MC			160μV/100Ω
MM			2.5mV/47kΩ
Aux, Tape			120mV/47kΩ
<b>Input Sensitivity (New IHF)</b>			
Phono MC			24μV
MM			0.37mV
Aux, Tape			18mV
<b>Maximum Input Signal</b>			
0.02% THD		Phono MC	7mV
		MM	110mV
<b>Output Level/Impedance</b>			
Rec Out			120mV/4.7kΩ
<b>Headphone Jack Rated Output/Impedance</b>			
0.015% THD			0.67V/220Ω
<b>Frequency Response</b>			
20Hz to 100kHz		Aux, Tape	-3dB
<b>RIAA Equalization Deviation</b>			
50Hz to 20kHz		Phono MC	±0.5dB
20Hz to 20kHz		Phono MM	±0.5dB
<b>Total Harmonic Distortion</b>			
Phono MC to Rec Out		(1V)	0.008%
MM		(1V)	0.008%
Aux, Tape to SP Out		1W/8Ω	0.008%
<b>Intermodulation Distortion</b>			
Aux, Tape Rated Output		/8Ω	0.008%
<b>Signal to Noise Ratio (IHF-A-Network)</b>			
Phono MC (500μV Input Shorted)			75dB/73dB (G)
MM (5mV Input Shorted)			88dB/86dB (G)
Aux, Tape, Tuner (Input Shorted)			100dB/98dB (G)
<b>Signal to Noise Ratio (New IHF)</b>			
Phono MC			74dB/72dB (G)
MM			72dB/70dB (G)
Aux, Tape, Tuner			81dB/80dB (G)
<b>Residual Noise (IHF-A-Network)</b>			
Channel Separation			140μV
<b>Channel Separation</b>			
Aux, Tape 5.1kΩ Shorted		1kHz	60dB
<b>Filter Characteristics</b>			
Low (Subsonic Built-in)			15Hz, -12dB/oct
<b>CCSS</b>			
LOUDNESS	Preset	60Hz	0dB
		250Hz	-2dB
		1kHz	-5dB
		4kHz	-5dB
		16kHz	-3dB
	MAX.	60Hz	-1dB
		250Hz	-5dB
		1kHz	-12dB
		4kHz	-11dB
		16kHz	-4dB
BASS	Preset	60Hz	5dB
		250Hz	3dB
		1kHz	1dB
		4kHz	0dB
		16kHz	0dB
	MAX.	60Hz	10dB
		250Hz	6dB
		1kHz	1dB
		4kHz	0dB
		16kHz	0dB
PRESENCE	Preset	60Hz	0dB
		250Hz	0dB
		1kHz	3dB
		4kHz	5dB
		16kHz	3dB
	MAX.	60Hz	-2dB
		250Hz	0dB
		1kHz	7dB
		4kHz	10dB
		16kHz	6dB

TREBLE	Preset	60Hz	0dB
		250Hz	0dB
		1kHz	0dB
		4kHz	3dB
		16kHz	6dB
	MAX.	60Hz	0dB
		250Hz	0dB
		1kHz	1dB
		4kHz	7dB
		16kHz	11dB
HIGH FILTER	Preset	60Hz	1dB
		250Hz	1dB
		1kHz	0dB
		4kHz	-5dB
		16kHz	-6dB
	MAX.	60Hz	1dB
		250Hz	1dB
		1kHz	-1dB
		4kHz	-8dB
		16kHz	-11dB
<b>Output Level/Impedance (Fixed)</b>			
FM 100% mod		1kHz	500mV/5kΩ
FM 40kHz mod			380mV/5kΩ (G)
AM 30% mod		400Hz	150mV/5kΩ

<b>FM SECTION</b>			
<b>Tuning Range</b>		87.5 to 108.0MHz	
<b>50dB Quieting Sensitivity (IHF, 75Ω)</b>			
Mono		1.6μV (15.3dBf)	
Stereo		22μV (38.1dBf)	
<b>Usable Sensitivity</b>			
30dB Quieting		75Ω	
		0.8μV (9.3dBf)	
<b>Usable Sensitivity (DIN, 75Ω)</b>			
Mono (S/N 26dB)		0.8μV (9.3dBf) (G)(B)(A)	
Stereo (S/N 46dB)		25μV (39.2dBf) (G)(B)(A)	
<b>Image Response Ratio</b>			
		50dB	
<b>IF Response Ratio</b>			
		90dB	
<b>Spurious Response Ratio</b>			
		70dB	
<b>AM Suppression Ratio</b>			
		60dB	
<b>Capture Ratio</b>			
		1.5dB	
<b>Alternate Channel Selectivity (IHF)</b>			
		55dB	
<b>Selectivity (two signals) (DIN)</b>			
		60dB (G)	
<b>Signal to Noise Ratio (IHF)</b>			
Mono		85dB	
Stereo		81dB	
<b>Signal to Noise Ratio (DIN-UNWeighted)</b>			
Mono		80dB (G)(B)(A)	
Stereo		76dB (G)(B)(A)	
<b>Harmonic Distortion</b>			
Mono		1kHz	
		0.1%	
Stereo		1kHz	
		0.15%	
<b>Harmonic Distortion (40kHz Dev)</b>			
Stereo		1kHz	
		0.15% (G)	
<b>Stereo Separation (IHF)</b>			
1kHz		40dB	
<b>Frequency Response</b>			
50Hz to 10kHz		±0.3dB	
<b>Sub-carrier Product Ratio (IHF)</b>			
		55dB	

<b>AM Section</b>			
<b>Tuning Range</b>		510 to 1620kHz (U)(C)	
		513 to 1620kHz (G)(A)(B)	
		510 to 1620kHz or	
		513 to 1620kHz (R)	
<b>Usable Sensitivity</b>			
		250μV/m	
<b>Selectivity</b>			
		25dB	
<b>Signal to Noise Ratio</b>			
		52dB	
<b>Image Response Ratio</b>			
		40dB	
<b>Spurious Response Ratio</b>			
		50dB	
<b>Harmonic Distortion (400Hz)</b>			
		0.3%	

<b>GENERAL</b>			
<b>Power Supply</b>			
US & Canadian Models		120V AC, 60Hz	
General Model and R-70M		110V, 120V, 220V, 240V AC, 50/60Hz	
European Model		220V AC, 50Hz	
British & Australian Models		240V AC, 50Hz	
<b>Power Consumption</b>			
		200W (U)(C)	
		320W (G)(A)(B)	
		120W (R)	
<b>AC Outlet</b>			
Switched		200W max.	
Unswitched		200W max.	
<b>Dimensions (W x H x D)</b>			
		435 x 122 x 386mm	
		(17-1/8 x 4-3/4 x 15-1/8)"	
<b>Weight</b>			
		8.3kg (18.3 lbs)	
(U) .... U.S.A. model		(G) .... European model	
(C) .... Canadian model		(B) .... British model	
(A) .... Australian model		(R) .... General model	

Specifications subject to change without notice.

## TO SERVICE PERSONNEL

(Prepared in accordance with UL Standard 1270)

Before service of this appliance by you, please carefully read this service manual.

Please make Leakage-current or Resistance measurements by suitable meter to determine that exposed parts are acceptably insulated from the supply circuit before returning the appliance to the customer.

- A PROBE WITH SHIELDED LEAD.
- B SEPARATED AND USED AS CLIP WHEN MEASURING CURRENTS FROM ONE PART OF APPLIANCE TO ANOTHER.

Confirm that the leakage current is not more than 0.5mA AC.

## REAR PANEL

### U.S.A. & Canadian models

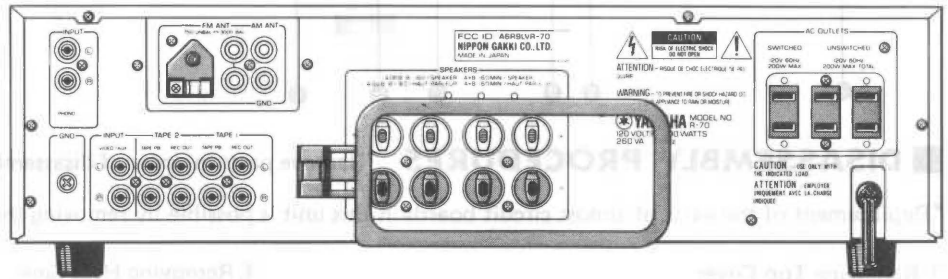

### General model (R-70M)

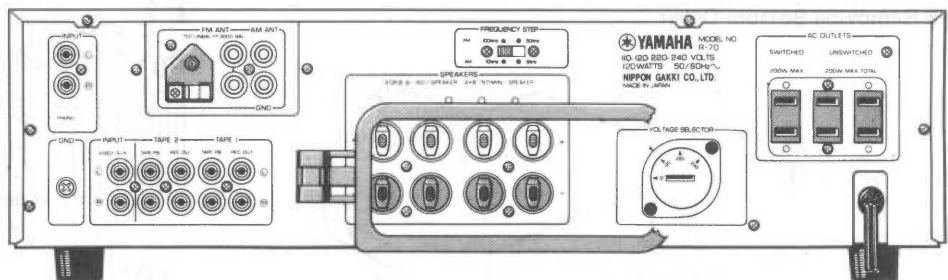

### British & Australian models

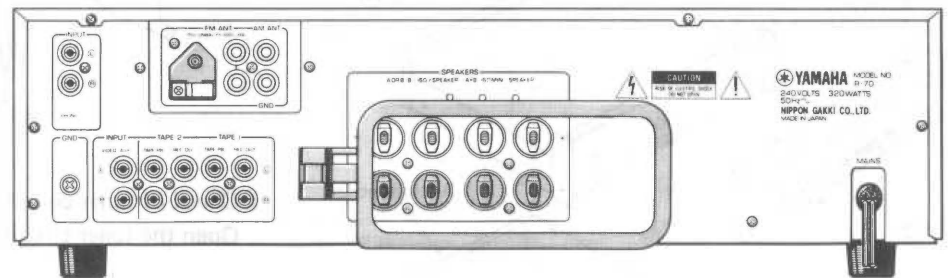

### European model

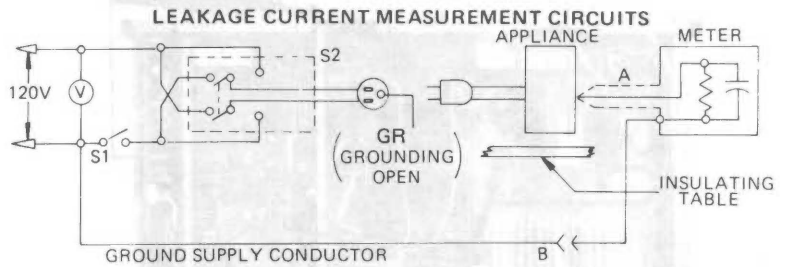
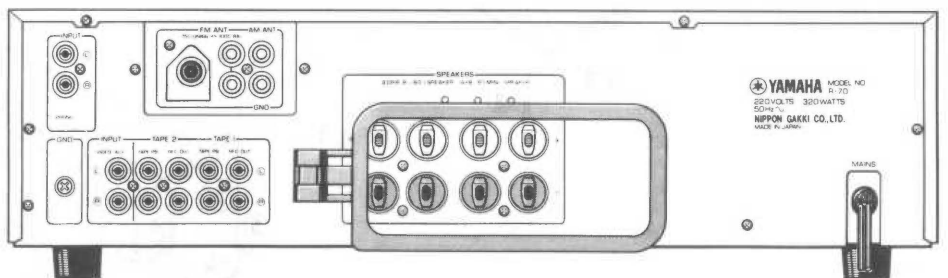

Appliance intended for connection to a 120 volt power supply.

**INTERNAL VIEW**

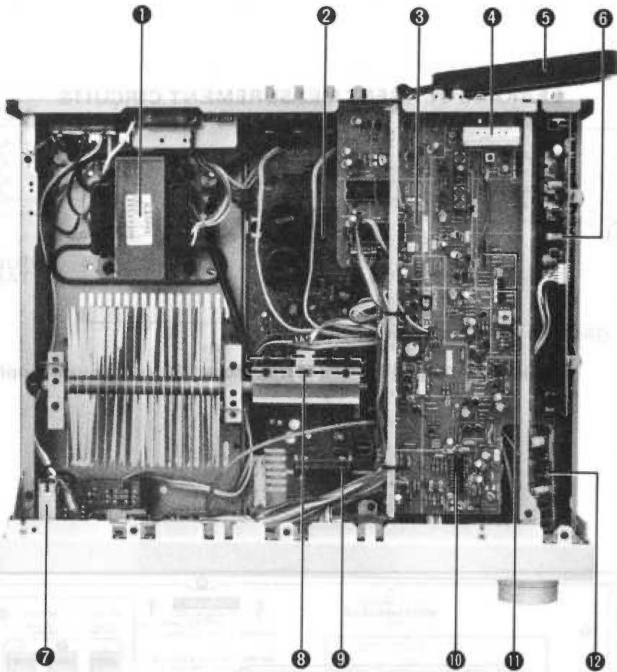

- ① POWER TRANSFORMER  
 U.S.A. & Canadian models : GA66450  
 European model : GA66470  
 British & Australian models : GA66480  
 General model, R-70M : GA66460
- ② MAIN CIRCUIT BOARD (1)
- ③ TUNER CIRCUIT BOARD (1)
- ④ FRONT END PACK
- ⑤ AM LOOP ANTENNA
- ⑥ TUNER CIRCUIT BOARD (2)
- ⑦ POWER SWITCH
- ⑧ POWER IC: STK2250Y
- ⑨ PRE DRIVE IC: STK3061Y
- ⑩ MPX IC: LA3380
- ⑪ IF IC:  $\mu$ PC577H (E, F)
- ⑫ MAIN CIRCUIT BOARD (3)

**DISASSEMBLY PROCEDURES** (Remove parts in order of disassembly as numbered)

\*Replacement of the parts of almost circuit boards in this unit is possible by removing the top and bottom cover.

- ① Removing Top Cover
- ② Removing Front Panel
- ③ Removing Bottom Cover

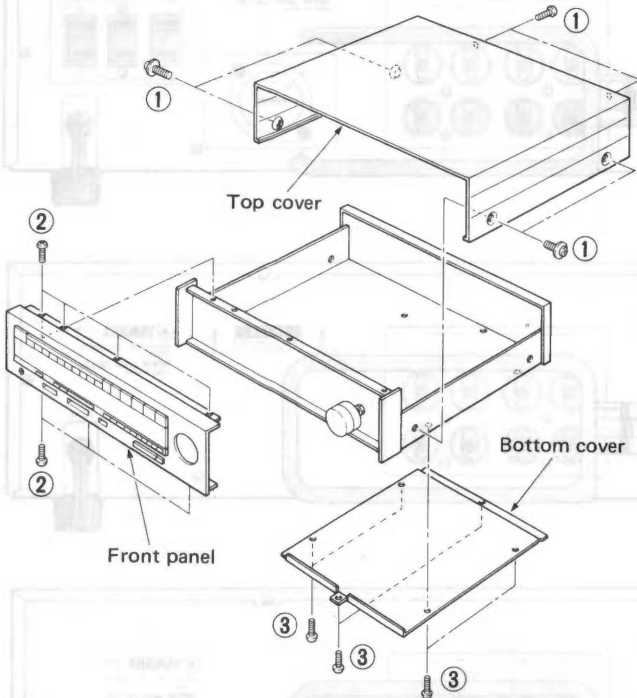

Fig. 1

- ④ Removing Heat Sink

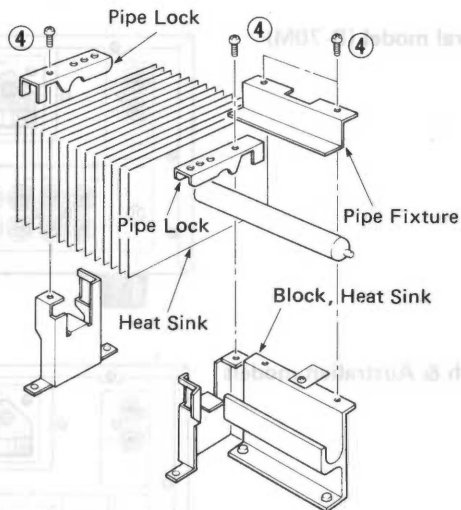

Fig. 2

- ⑤ Check of tuner circuit board (1) & replacement parts  
 Open the tuner circuit board (1) as shown in Fig. 3.

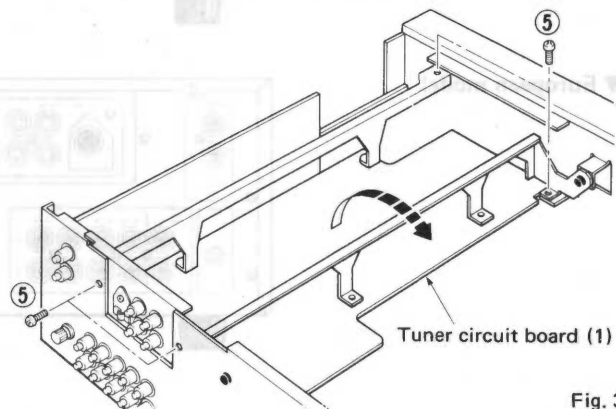

Fig. 3

## ADJUSTMENTS

### <CONFIRMATION OF AUDIO SECTION>

#### Before adjustment

Note 1: After the power switch is pushed on, wait for 5 minutes before measuring, to be sure of the most stable operation.

Step	Confirmation	Test point	Rating or standard	Adjustment method	Remark								
1	Power supply voltage	+B -B +16 -16 +12 +5 +8 -8	+43V ± 8V -43V ± 8V +16V ± 2V -16V ± 2V +12.5V ± 1V +5.5V ± 0.5V +8V ± 1V -8V ± 1V	Make sure that AC line voltage comes within <table border="1"> <thead> <tr> <th>Models</th> <th>AC line voltage</th> </tr> </thead> <tbody> <tr> <td>U, C</td> <td>120V ± 10%</td> </tr> <tr> <td>G</td> <td>220V ± 10%</td> </tr> <tr> <td>A, B</td> <td>240V ± 10%</td> </tr> </tbody> </table>	Models	AC line voltage	U, C	120V ± 10%	G	220V ± 10%	A, B	240V ± 10%	No load
Models	AC line voltage												
U, C	120V ± 10%												
G	220V ± 10%												
A, B	240V ± 10%												
2	Gain	IC414, across pin 4 and E (Lch) across pin 13 and E (Rch)	+10V ± 1V	Apply a 1kHz, 100mV sine wave signal to the points "BL" and "BR"									
4	DC offset	IC414, across pin 4 and E (Lch) across pin 13 and E (Rch)	0V ± 70mV										
5	PHONO amp	PL, PR	+120mV ± 20mV	Apply a 1kHz, 2.5mV sine wave signal to PHONO INPUT	PHONO selector set "MM"								
				Apply a 1kHz, 160μV sine wave signal to PHONO INPUT	PHONO selector set "MC"								

### <TUNER ADJUSTMENT>

#### ● Before adjustment

Note 1) After the Power switch is pushed on, wait for 5 minutes before measuring, to be sure of the most stable operation.

Note 2) Adjust the OSC coil and IFT with a nonferrous screw driver.

Note 3) Do not forget to keep the bottom cover on.

#### ● Measuring instruments abbreviation

FM SG : FM signal generator

SSG : Stereo signal generator

AM SG : AM signal generator

OSC : Oscilloscope

DIST. M : Distortion meter

FC : Frequency counter

ACVM : AC volt meter

### 1. FM TUNER SECTION

● Use 200Hz to 15kHz bandpass filter to measure the REC OUT.

● On step 1 and 2 connect the auxiliary center meter (Ji00036 or similar) in series with the resistor 10kΩ between TP1 (S OUT) and TP2 (NVcc).

● Set the switches to the following positions.

INPUT . . . . . TUNER

Band Select . . . . . FM

TUNING/MODE . . . . . AUTO

VOLUME . . . . . Min

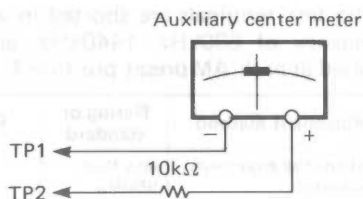

Step	Adjustment item	Connection terminal	Instrument required	Adjustment locations	Adjustment method	Rating or standard	Remarks
1	Discriminator balance adjustment	TP1 ~ TP2 (S out)(NVcc)	Auxiliary center meter	T102 (DISCRI CENTER)	Adjust so that the pointer of the auxiliary center meter points to 0 at detuned point.		
2	Station center set confirmation	300Ω FM ANT TP1 ~ TP2 (S out)(NVcc)	FM SG 98MHz ± 1kHz 70dBμ (75.2dBf) MONO 1kHz 100% MOD Auxiliary center meter	TUNING SW → UP or DOWN	Confirm that the auxiliary center meter deflects to 0 when tuned to signal of FM SG		
3	Monaural distortion adjustment	300Ω FM ANT REC OUT (TP6, TP7)	FM SG 98MHz ± 1kHz 70dBμ (75.2dBf) monaural 100Hz or 400Hz 100% MOD DIST. M. OSC BPF	VC101 (MONO DIST) Signal Q	Reduce distortion to minimum	Less than -64dB	Confirm that all signal Q indicators light

Step	Adjustment item	Connection terminal	Instrument required	Adjustment locations	Adjustment method	Rating or standard	Remarks
4	VCO adjustment	300Ω FM ANT  TP4 ~ TP5 (19M) (+12) TP3 ~ GND (19kHz)	FM SG 98MHz ± 1kHz 70dBμ (75.2dBf) Unmodulated Resistor 2.2MΩ  FC	VR103 (VCO)  Stereo indicator	① Connect resistor 2.2MΩ between TP4 (19M) and TP5 (+12) and force the set in stereo mode. ② Adjust so that VCO frequency is at 19kHz	19kHz ± 10Hz	Confirm that stereo indicator lights up. After adjusting, remove the FC and the 2.2MΩ resistor.
5	Stereo distortion adjustment	300Ω FM ANT  REC OUT (TP6, TP7)	FM SG, SSG 98MHz ± 1kHz 70dBμ (75.2dBf) STEREO L, R 1kHz, 100% MOD DIST. M, OSC BPF	T101 (ST DIST)	Same as step 3	Less than -48dB G model only Less than -33dB	
6	Separation confirmation	300Ω FM ANT  REC OUT (TP6, TP7)	FM SG, SSG 98MHz ± 1kHz 70dBμ (75.2dBf) STEREO L or R 1kHz, 100% MOD OSC, ACVM, BPF		Confirm that the leakage level of the opposite channel is minimum	Less than 26dB	
7	Pilot cancel adjustment	300Ω FM ANT  REC OUT (TP6, TP7)	FM SG, SSG 98MHz ± 1kHz 70dBμ (75.2dBf) PILOT 9% MOD OSC Disconnect BPF	VR102 (PILOT CANCEL)	Observe waveform on the OSC and adjust so that carrier leakage level reduced to minimum	More than 46dB	
8	If offset adjustment	300Ω FM ANT  TEST terminals (K4, T6)	FM SG 98MHz ± 1kHz 70dBμ (75.2dBf) Short	VR106 (FM FINE)	By shorting TEST terminals, the counter shifts by one digit, then adjust so that the lowest effective digit comes to 9 or 0.  This figure 98.0MHz — 80.0 79.9 When shifting		After adjusting, open the TEST terminals.
9	Auto search reception confirmation	300Ω FM ANT	FM SG 98MHz ± 1kHz 20dBμ (25.2dBf) MONO 1kHz 100% MOD	TUNING SW → UP or DOWN	Confirm that auto search reception is possible with the tuning button.		Confirm that muting is performed at auto reception.

2. AM TUNER SECTION

●Connect the AM dummy antenna for adjustment.

●When once the test terminals are shorted in adjusting FM, the frequency of 630kHz, 1440kHz, and 1080 kHz is memoried at each AM preset position 1, 2 and 3.

Step	Adjustment item	Connection terminal	Instrument required	Adjustment locations	Adjustment method	Rating or standard	Remarks
1	Sensitivity confirmation	AM ANT  REC OUT (TP6, TP7)	AM dummy antenna AM SG 400Hz, 30% MOD 50dBμ 630kHz ± 0.1kHz 1440kHz ± 0.1kHz 1080kHz ± 0.1kHz OSC: DST. M ACVM	PRESET P1 P2 P3	Confirm the maximum sensitivity	less than 55dBμ	
2	Signal Q indicator confirmation	AM ANT	AM dummy antenna AM SG 1080kHz ± 0.1kHz 80dBμ	PRESET P3 Signal Q	Confirm that all signal Q indicators light		Confirm that all signal Q indicators go out at detuned point
3	Auto search reception confirmation	AM ANT	AM dummy antenna AM SG 1080kHz ± 0.1kHz 60dBμ	TUNING SW → UP or DOWN	Confirm that auto search reception is possible with the tuning button.		

3. DIGITAL CONTROL SECTION

Step	Adjustment item	Connection terminal	Instrument required	Adjustment locations	Adjustment method	Rating or standard	Remarks
1	Preset memory confirmation	300Ω FM ANT  AM ANT	FM SG 98MHz ± 1kHz 70dBμ (75.2dBf) MONO 1kHz 100% MOD  AM dummy antenna AM SG 1080kHz ± 0.1kHz 80dBμ 400Hz, 30% MOD	FM/AM SW  TUNING SW MEMORY SW  PRESET SW	① Memorize the PRESET P1 at FM SG frequency. ② Memorize the PRESET P2 at AM SG frequency. ③ Confirm that the frequency memorized is recalled.		① Press the FM button and tuned the 98MHz with AUTO search ↓ Press the Memory button. ↓ The Memory indicator lights about 3 seconds ↓ Press the PRESET P1 during the Memory indicator lights. ↓ The PRESET LED of P1 lights.  ② Press the AM button and tuned the 1080kHz with AUTO search. ↓ Press the Memory button ↓ The Memory indicator lights and the PRESET LED of P1 flashes. ↓ Press the PRESET P2 ↓ The Memory indicator goes out and the PRESET LED of P2 lights.
2	Last channel memory confirmation			POWER SW	① Press the PRESET P1 ② Turn the power switch off. ③ After about 5 seconds, turn the power switch on. ④ Confirm that the PRESET P1 memorized is recalled.		④ The PRESET of P1 not lights

●TEST POINT

Main circuit board (1)

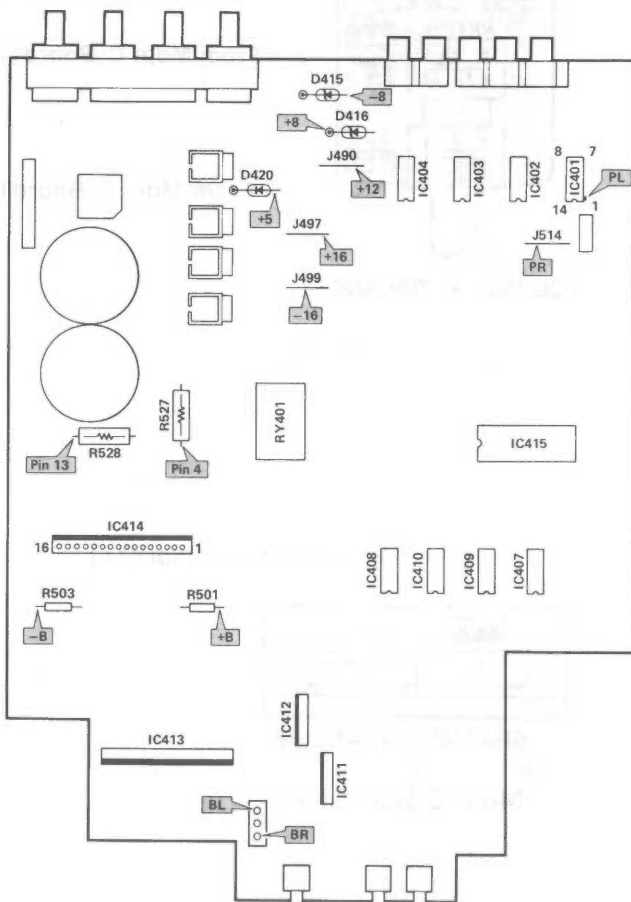

Tuner circuit board (1)

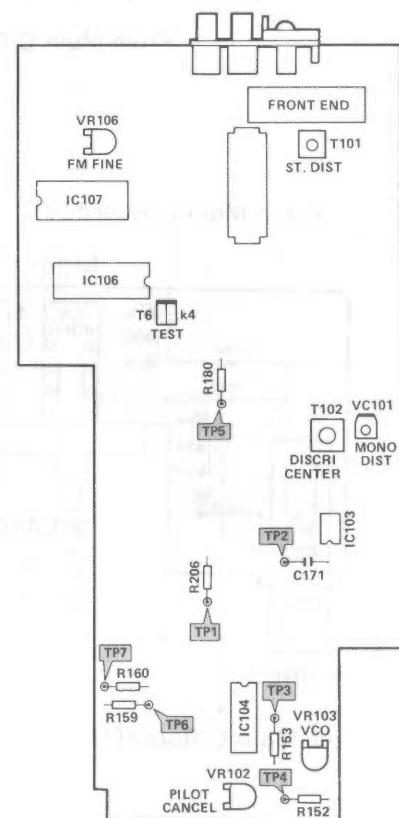

# PRINTED CIRCUIT BOARD (Pattern side)

## Key circuit board (1)

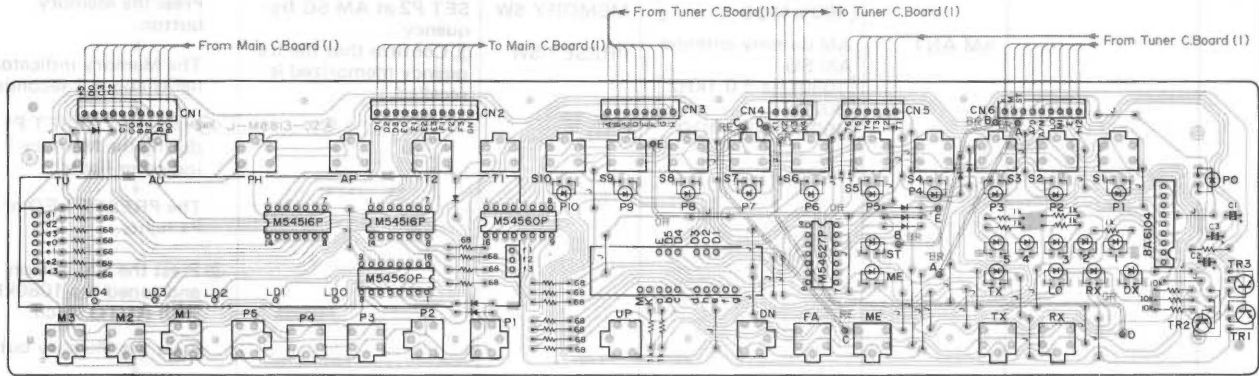

## Main circuit board (2/5 ~ 5/5)

### Main C.Board (5)

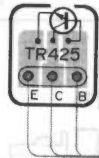

From Main C.Board (1)

### Main C.Board (3)

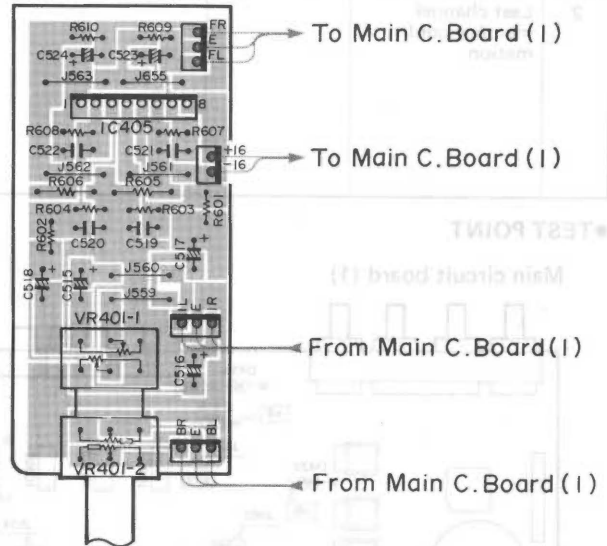

VOLUME — BALANCE

From Main C.Board (1)

### Main C.Board (2)

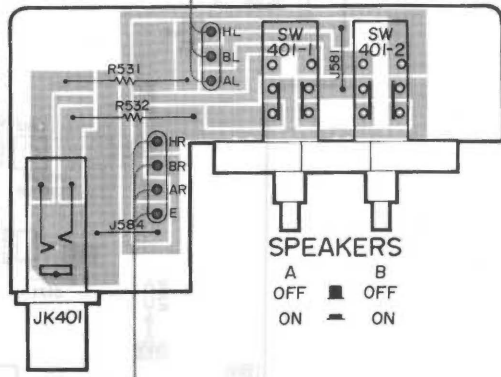

From Main C.Board (1)

**SPEAKERS**  
 A      B  
 OFF    OFF  
 ON     ON

From Main C.Board (1)

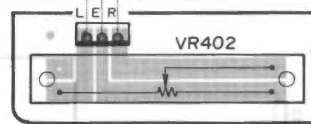

**SPATIAL EXPANDER**  
 10      5      0  
 Main C.Board (4)







SCHEMATIC DIAGRAM

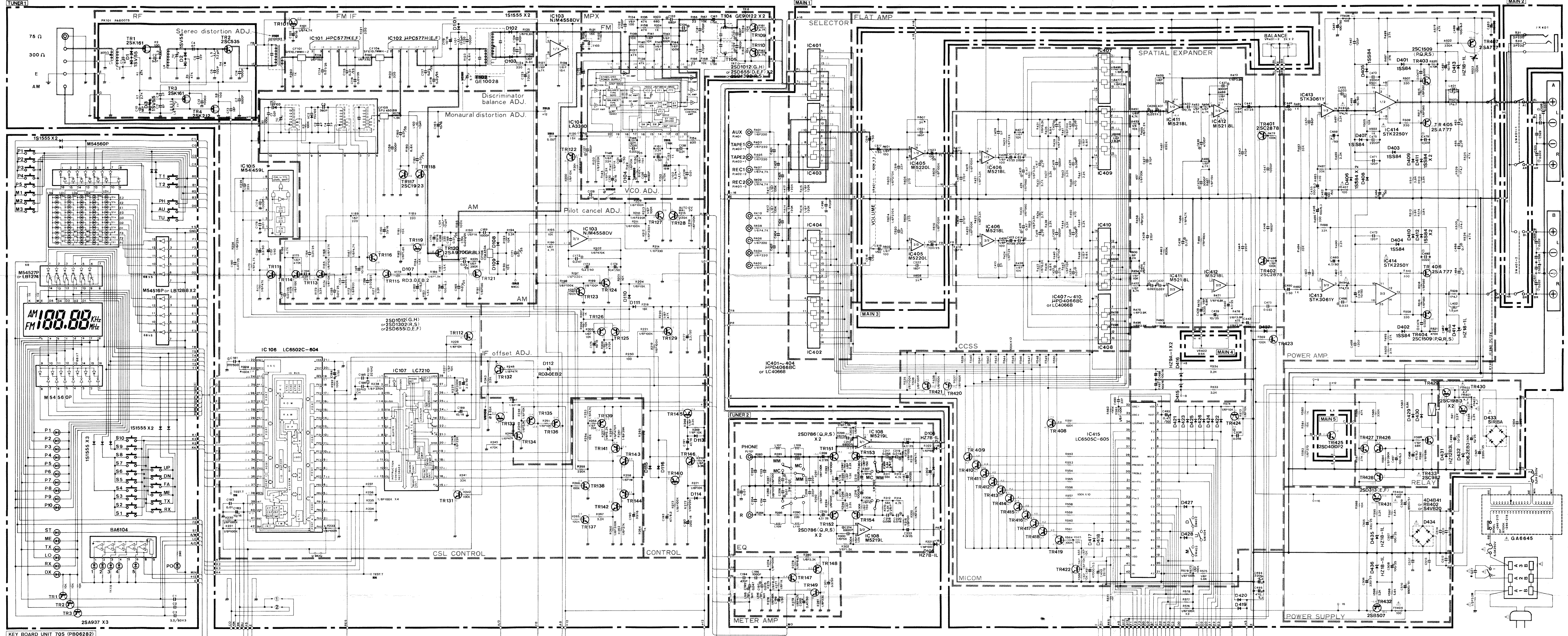

KEY BOARD UNIT 705 (P06212)

RESISTOR	REMARKS	PARTS NAME	CAPACITOR	REMARKS	PARTS NAME
NO MARK	CARBON FILM RESISTOR		NO MARK	ELECTROLYTIC CAPACITOR	
*	METAL OXIDE FILM RESISTOR		NO MARK	CERAMIC CAPACITOR	
*	METAL PLATE RESISTOR		*	POLYESTER FILM CAPACITOR	
*	FLAME PROOF CARBON FILM RESISTOR		*	SEMICONDUCTIVE CERAMIC CAPACITOR	
*	SEMI-VARIABLE RESISTOR		0	MICA CAPACITOR	

NOTE: TR101, 111, 113, 114, 116, 118, 121 ~ 124, 127 ~ 129, 131, 132, 134, 137, 138, 142, 143, 147, 149, 420 ~ 422, 424, 426, 427, TR12, 119, 125, 126, 133, 135, 136, 139 ~ 141, 144 ~ 146, 148, 407 ~ 419, 423, 428, D101, 104, 108 ~ 111, 113 ~ 116, 417 ~ 430, 437, 438, 439, 440, 441, 442, 443, 444, 445, 446, 447, 448, 449, 450, 451, 452, 453, 454, 455, 456, 457, 458, 459, 460, 461, 462, 463, 464, 465, 466, 467, 468, 469, 470, 471, 472, 473, 474, 475, 476, 477, 478, 479, 480, 481, 482, 483, 484, 485, 486, 487, 488, 489, 490, 491, 492, 493, 494, 495, 496, 497, 498, 499, 500, 501, 502, 503, 504, 505, 506, 507, 508, 509, 510, 511, 512, 513, 514, 515, 516, 517, 518, 519, 520, 521, 522, 523, 524, 525, 526, 527, 528, 529, 530, 531, 532, 533, 534, 535, 536, 537, 538, 539, 540, 541, 542, 543, 544, 545, 546, 547, 548, 549, 550, 551, 552, 553, 554, 555, 556, 557, 558, 559, 560, 561, 562, 563, 564, 565, 566, 567, 568, 569, 570, 571, 572, 573, 574, 575, 576, 577, 578, 579, 580, 581, 582, 583, 584, 585, 586, 587, 588, 589, 590, 591, 592, 593, 594, 595, 596, 597, 598, 599, 600, 601, 602, 603, 604, 605, 606, 607, 608, 609, 610, 611, 612, 613, 614, 615, 616, 617, 618, 619, 620, 621, 622, 623, 624, 625, 626, 627, 628, 629, 630, 631, 632, 633, 634, 635, 636, 637, 638, 639, 640, 641, 642, 643, 644, 645, 646, 647, 648, 649, 650, 651, 652, 653, 654, 655, 656, 657, 658, 659, 660, 661, 662, 663, 664, 665, 666, 667, 668, 669, 670, 671, 672, 673, 674, 675, 676, 677, 678, 679, 680, 681, 682, 683, 684, 685, 686, 687, 688, 689, 690, 691, 692, 693, 694, 695, 696, 697, 698, 699, 700, 701, 702, 703, 704, 705, 706, 707, 708, 709, 710, 711, 712, 713, 714, 715, 716, 717, 718, 719, 720, 721, 722, 723, 724, 725, 726, 727, 728, 729, 730, 731, 732, 733, 734, 735, 736, 737, 738, 739, 740, 741, 742, 743, 744, 745, 746, 747, 748, 749, 750, 751, 752, 753, 754, 755, 756, 757, 758, 759, 760, 761, 762, 763, 764, 765, 766, 767, 768, 769, 770, 771, 772, 773, 774, 775, 776, 777, 778, 779, 780, 781, 782, 783, 784, 785, 786, 787, 788, 789, 790, 791, 792, 793, 794, 795, 796, 797, 798, 799, 800, 801, 802, 803, 804, 805, 806, 807, 808, 809, 810, 811, 812, 813, 814, 815, 816, 817, 818, 819, 820, 821, 822, 823, 824, 825, 826, 827, 828, 829, 830, 831, 832, 833, 834, 835, 836, 837, 838, 839, 840, 841, 842, 843, 844, 845, 846, 847, 848, 849, 850, 851, 852, 853, 854, 855, 856, 857, 858, 859, 860, 861, 862, 863, 864, 865, 866, 867, 868, 869, 870, 871, 872, 873, 874, 875, 876, 877, 878, 879, 880, 881, 882, 883, 884, 885, 886, 887, 888, 889, 890, 891, 892, 893, 894, 895, 896, 897, 898, 899, 900, 901, 902, 903, 904, 905, 906, 907, 908, 909, 910, 911, 912, 913, 914, 915, 916, 917, 918, 919, 920, 921, 922, 923, 924, 925, 926, 927, 928, 929, 930, 931, 932, 933, 934, 935, 936, 937, 938, 939, 940, 941, 942, 943, 944, 945, 946, 947, 948, 949, 950, 951, 952, 953, 954, 955, 956, 957, 958, 959, 960, 961, 962, 963, 964, 965, 966, 967, 968, 969, 970, 971, 972, 973, 974, 975, 976, 977, 978, 979, 980, 981, 982, 983, 984, 985, 986, 987, 988, 989, 990, 991, 992, 993, 994, 995, 996, 997, 998, 999, 1000.

BLOCK DIAGRAM

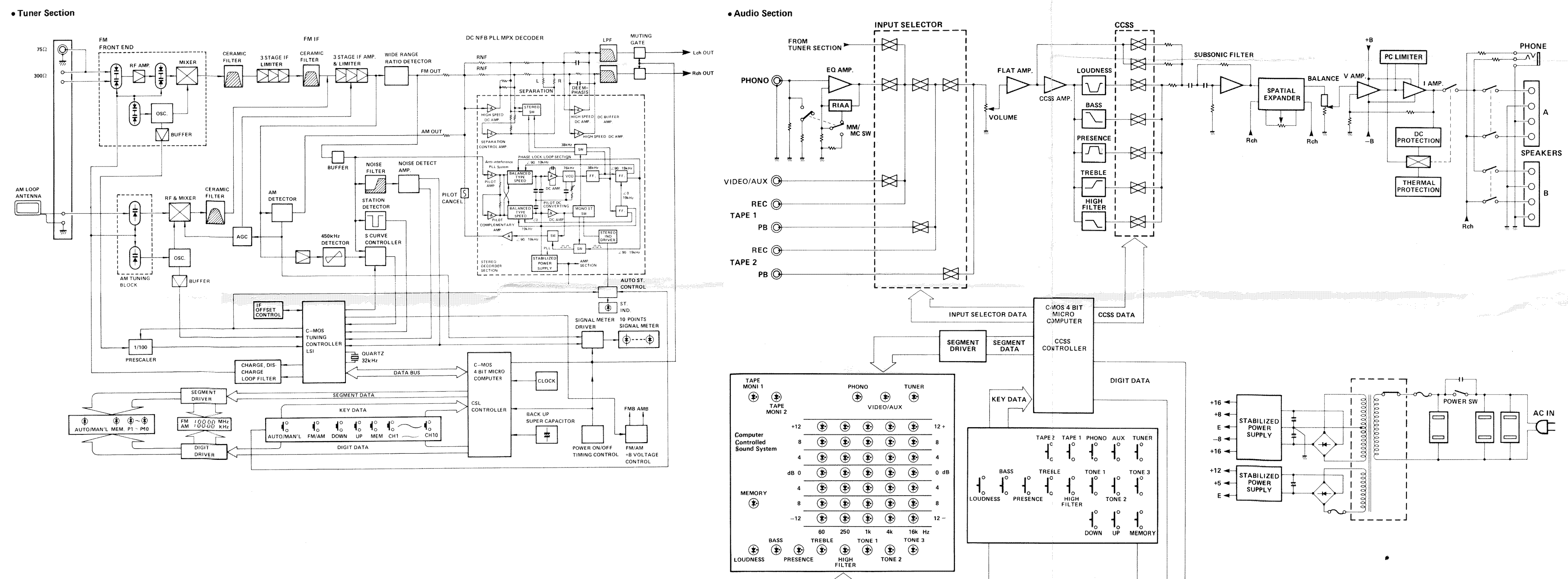

This schematic diagram is for U.S. and Canadian models. The following parts and values differ from each model, so refer to the corresponding column.

CF101, 104	R, LR	U, C	A, B	G
C103, 110	Open	Open	270p	2200p
C12, 122	820p	820p	820p	1000p
C127	680p	680p	680p	470p
C133, 134	680p	680p	470p	0.01
C164	0.022	0.022	0.022	100p
C203, 204	Open	Open	220p	470p
C207, 208	220p	220p	220p	0.022
C213, 214	6800p	6800p	6800p	15uH
L107, 108	Open	Open	Open	220uH
L109, 110	Open	Open	Open	Set
T103	Open	Open	Open	Open
T104, 105	Open	Open	Open	Open
R129	15k	15k	15k	15k
R132	Open	Open	Open	12k
R135, 136	47k	47k	47k	59k
R157, 158	10k	10k	10k	10k
R159, 160	10k	10k	10k	33k
R185	100k	100k	100k	120k
R207	1k	1k	1k	2.2k
R285	1k	1k	1k	Open
R283, 284	Short	Short	Short	50
R286, 286	Short	Short	Short	560
R290, 290	220	220	220	2.2k
R323	680	680	680	220
R324	1k	1k	1k	680
C401 ~ 406	Open	Open	Open	200p
C813, 814	Open	Open	Open	0.022
C820, 821	Open	Open	Open	Open
833, 835, 837	Open	Open	Open	Open
R401 ~ 406	220	220	220	2.2k
→	Open	Open	Open	Open
TUNER (3)	Set	Set	Set	Open

\*Schematic diagram is subject to change without notice.

FM/AM SELECTORS → FM  
FUNCTION → TUNER  
TUNING MODE → AUTO

\*All voltages are measured with a 10MΩ/V DC electric volt meter. The voltage in the tuner section are measured in FM reception mode. Only the voltages at TR13 ~ TR21 are measured in AM reception mode.

WARNING: UL Standard 1270 requires that components marked Δ be replaced with parts having specifications equal to those originally installed.

GENERAL MODEL AND R-70M

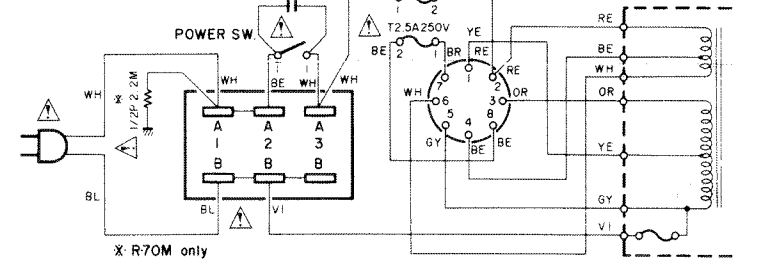

AUSTRALIAN & BRITISH MODELS

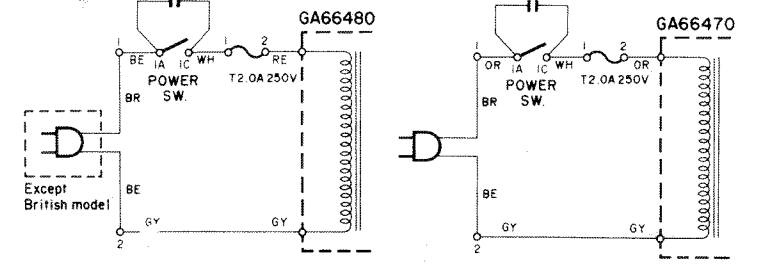

EUROPEAN MODEL

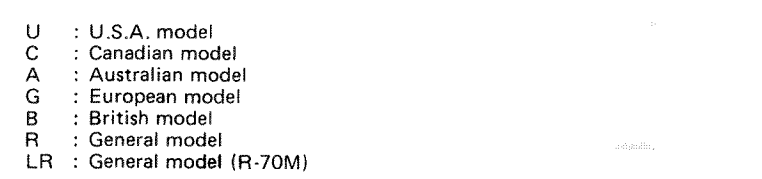

U : U.S.A. model  
C : Canadian model  
A : Australian model  
G : European model  
B : British model  
R : General model  
L.P. : General model (R-70M)

# PARTS LIST

R-70/R-70M

■WARNING

UL Standard 1270 requires that components marked  $\Delta$  be replaced with parts having specifications equal to those originally installed.

● Carbon resistors of this receiver are  $\frac{1}{4}W$ . There is no discription about them in this parts list. Use the "Part No." HJ350000 or equivalent.

■ ELECTRICAL PARTS

Ref. No.	Part No.	Description	部 品 名	Remarks	Common Model	Markets
※	NA 08 17 80	Tuner Circuit Board	チューナーシート			R,LR
※	NA 08 17 90	"	"			U,C
※	NA 08 18 00	"	"			A,B
※	NA 08 18 10	"	"			G
	FG 41 21 00	Ceramic Cap.	セラコン	C203,204		G
	FG 41 22 20	"	"	C207,208		R,U,A,C,B LR
	FG 41 24 70	"	"	"		G
	FG 41 22 70	"	"	C103,104		G
	FG 41 31 00	"	"	C169,179		
	FG 44 41 00	"	"	C128,178,182,223		
	Fi 19 12 20	"	"	C185,186		
	Fi 19 21 00	"	"	C124,125		
	FG 21 31 00	"	"	C120,159,196		
	FG 21 24 70	"	"	C194		
	FG 21 34 70	"	"	C132,141,142		
	Fi 22 41 00	"	"	0.01 $\mu$ F 25V	C114-118,154-157,160,161, 165,167,168,171,180	
	Fi 22 41 00	"	"	0.01 $\mu$ F 25V	C164	G
	Fi 22 42 20	"	"	0.022 $\mu$ F 25V	"	R,U,A,C,B LR
	Fi 22 42 20	"	"	0.022 $\mu$ F 25V	C135,153,158	
	FS 25 26 80	Semi Conductive Ceramic Cap.	S A コ ン	C136		
	FU 35 12 70	Mica Cap.	マイカコン	C181		
	UA 25 24 70	Mylar Cap.	マイラーコン	C133,134		A,G,B
	UA 25 26 80	"	"	"		R,U,C,LR
	UA 25 26 80	"	"	C127		R,U,A,C,B LR
	UA 25 31 00	"	"	"		G
	UA 25 31 50	"	"	C126		
※	UA 25 28 20	"	"	C121,122		R,U,A,C,B LR
	UA 25 32 20	"	"	"		G
	UA 25 36 80	"	"	C213,214		R,U,A,C,B LR
	UA 25 42 20	"	"	"		G
	UA 25 41 00	"	"	C138,139,205,206		
	UA 25 41 50	"	"	C197		
	UA 25 41 60	"	"	C219,220		
	UA 25 44 70	"	"	C172,195		
	UA 25 45 60	"	"	C217,218		
※	Ui 91 91 00	Electrolytic Cap.	ケ ミ コ ン	C215,216		
	UW 91 74 70	"	"	C193		
	UW 91 82 20	"	"	C123		
	UW 93 71 00	"	"	C102,119,129,130,149,163,170, 175,183,189		
	UW 93 73 30	"	"	C150,162,166,190		
	UW 93 74 70	"	"	C191,211,212		
	UW 93 82 20	"	"	C192		
	UW 94 64 70	"	"	C209,210,221,222		
	UW 94 81 00	"	"	C187,202		
	UW 96 54 70	"	"	C173,174,184,200		
	UW 96 61 00	"	"	C131,137,143,144,151,199		
	UW 96 62 20	"	"	C152,177		
	UW 96 63 30	"	"	C188,201		
	FY 00 01 90	Trimmer Cap.	トリマーコン	VC101		
	GE 10 02 80	FM Discriminator Coil	FMディスクリコイル	T102		
※	GE 10 06 50	FM IFT Coil	FM IFT コイル	T101		

※ New Parts (新規部品)

Ref. No.	Part No.	Description	部 品 名	Remarks	Common Model	Markets
GE 20 04 30	Anti Birdie Filter	114kHz	アンチバーディーフィルター	T103		G
GE 90 12 10	Low-pass Filter	5.6k : 33k	ローパスフィルター	T104,105		G
GE 90 12 20	"	10k : 10k	"	T104,105		R,U,A,C,B LR
GE 30 04 50	Inductor	1 mH	インダクター	L105,106		
GE 30 05 00	"	12 μH	"	L103,104		
GE 30 05 10	"	120 μH	"	L101		
GE 90 03 30		220 μH	チョークコイル	L109,110		G
GE 90 08 40		15 μH	"	L107,108		G
GE 90 06 90	RF Inductor	8.2 mH	R F インダクター	L102		
GG 00 04 20	AM Ceramic Discriminator	CDA450A	AMセラミックディスクリ	CF106		
GG 00 06 20	FM Ceramic Filter	SFE10.7MS 3GHY-Z	FMセラミックフィルター	CF101,104		G
GG 00 06 30	"	SFE10.7 MMH-Z	"	"		R,U,A,C,B LR
GG 00 06 60	AM Ceramic Filter	SFU450B9	AMセラミックフィルター	CF105		
HF 85 41 00	Carbon Resistor	10Ω 1/6W	カーボン抵抗	R307,308		
HF 85 43 30	"	33Ω "	"	R283,284		G
HF 85 45 60	"	56Ω "	"	R299,300		
HF 85 51 00	"	100Ω "	"	R134,176,287,288,315,316, 321,322,191		
HF 85 51 50	"	150Ω "	"	R119,305,306		
HF 85 52 20	"	220Ω "	"	R169,272,281		
HF 85 53 30	"	330Ω "	"	R120,214		
HF 85 55 60	"	560Ω "	"	R285,286		G
HF 85 58 20	"	820Ω "	"	R172		
HF 85 61 00	"	1kΩ "	"	R147,190,277		
HF 85 61 20	"	1.2kΩ "	"	R145		
HF 85 61 50	"	1.5kΩ "	"	R186,295,296,301~304		
HF 85 61 80	Carbon Resistor	1.8kΩ	"	R182		
HF 85 62 20	"	2.2kΩ "	"	R257,297,298		
HF 85 63 30	"	3.3kΩ "	"	R249,268,270,280		
HF 85 64 70	"	4.7kΩ "	"	R101,127,167,170,196,253, 279		
HF 85 65 60	"	5.6kΩ "	"	R309,310		
HF 85 66 80	"	6.8kΩ "	"	R125,126,278		
HF 85 68 20	"	8.2kΩ "	"	R275		
HF 85 71 00	"	10kΩ "	"	R141,142,165,174,200,205, 227,228,248,251,269,271		
HF 85 71 50	"	15kΩ "	"	R128,150,204		
HF 85 72 20	"	22kΩ "	"	R146,225,226,240		
HF 85 72 70	"	27kΩ "	"	R168,262		
HF 85 73 30	"	33kΩ "	"	R149,256		
HF 85 74 70	"	47kΩ "	"	R171,220,244,246,319,320		
HF 85 73 90	"	39kΩ "	"	R261		
HF 85 76 80	"	68kΩ "	"	R276		
HF 85 81 00	"	100kΩ "	"	R143,144,198,199,202,211,213,216, 219,221,230,231,233,237,213,216, 274,281~294		
HF 85 82 20	"	220kΩ "	"	R133,197,201,210,212,238		
HF 85 83 30	"	330kΩ "	"	R239,260		
HF 85 83 90	"	390kΩ "	"	R325		
HF 85 84 70	"	470kΩ "	"	R175,208,202,259		
HF 85 91 00	"	1MΩ "	"	R247,258		
HU 57 81 00	Metal Film Resistor	100kΩ	金属被膜抵抗	R229		
HT 37 00 50	Semi Variable Resistor	B5kΩ	半固定抵抗	VR106		
HT 37 00 20	"	B10kΩ	"	VR103		

\* New Parts (新規部品)

Ref. No.	Part No.	Description	部 品 名	Remarks	Common Model	Markets
	HT 37 00 30	Semi Variable Resistor	B100k $\Omega$	半 固 定 抵 抗	VR102	
	iA 09 70 00	Transistor	2SA970(GR,BL)	ト ラ ン ジ ス タ	TR120	
	iA 09 99 10	"	2SA999(E,F)	"	TR112,119,125,126,133,139-141,144-146,148	} Inter-changeable
	iA 11 27 00	"	2SA1127(R,S,T)	"	"	
	iA 09 99 10	"	2SA999(E,F)	"	TR135,136	
※	iC 19 23 00	"	2SC1923	"	TR117	
	iC 23 20 10	"	2SC2320(E,F)	"	TR101,111,113,114,116,118,121-124,127-129,131,132,134,137,138,142,143,147,149	} Inter-changeable
	iC 26 34 00	"	2SC2634(R,S,T)	"	"	
	iD 06 55 00	"	2SD655(D,E,F)	"	TD109,110,115	} Inter-changeable
※	iD 10 12 00	"	2SD1012(G,H)	"	"	
※	iD 13 02 00	"	2SD1302(R,S)	"	"	
※	iD 07 86 00	"	2SD786(Q,R,S)	"	TR151~154	
	iF 00 00 40	Diode	1S1555	ダ イ オ ー ド	D102,103	
	iF 00 00 40	"	1S1555	"	D101,104,108~111,113~116	} Inter-changeable
	iF 00 06 70	"	1S2473	"	"	
	iF 00 18 40	Zener Diode	RD3.0EB2	ツェナーダイオード	D107,112	
	iF 00 29 90	"	HZ7B-1L	"	D105,106	
	iG 00 13 90	IC	NJM4558DV	I C	IC103	
	iG 02 92 20	"	LA3380	"	IC104	
	iG 03 45 00	"	PC577H(E,F)	"	IC101,102	
	iG 04 14 00	"	M54459L	"	IC105	
	iG 04 91 00	"	LC7210	"	IC107	
※	iG 08 53 00	"	LC6502C-604	"	IC106	
※	iG 09 21 00	"	M5219L	"	IC107	
	KA 40 09 40	Slide Switch	SSB-022	ス ラ イ ド ス イ ッ チ	SW101	R,LR
※	KA 90 51 80	Remote Switch	SSR2635	リ モ ー ト ス イ ッ チ	SW102 PHONO	
※	LB 20 24 90	Pin Jack	2P	ピ ン ジャ ッ ク	PJ101	
※	QU 00 39 00	Quartz Crystal Unit	32kHz	水 晶 振 動 子	XL101	
※	PA 00 07 50	Front End Pack	FE529U12	フ ロ ン ト エ ン ド パ ッ ク	PK101	
	LA 00 39 90	Antenna Terminal	5P	ア ン テ ナ 端 子 板		R,U,A,C,B,LR
	LA 00 40 00	"	5P	"		G
	LB 20 13 90	2.5Pitch Base Pin	TEB2P-SHF	2.5ピッチベースピン		
	LB 91 20 50	Short Plug	5P i-Type	シ ョ ー ト プ ラ グ		
※	LB 91 20 90	"	9P i-Type	"		
※	LB 92 10 40	Connector Plug	4P i-Type	コ ネ ク タ ー プ ラ グ		
※	LB 92 10 60	"	6P i-Type	"		
※	LB 92 10 80	"	8P i-Type	"		
※	LB 92 10 90	"	9P i-Type	"		
※	NA 08 10 80	AM Coil Pack		A M コ イ ル パ ッ ク		
※	NA 08 19 00	Main Circuit Board		メ イ ン シ ー ト		R,A,B
※	NA 08 19 10	"		"		U,C,LR
※	NA 08 19 20	"		"		G
	FG 41 05 00	Ceramic Cap.	5pF 50V	セ ラ コ ン	C409,410	
	FG 41 13 30	"	33pF 50V	"	C490,519,520	

※ New Parts (新規部品)

Ref. No.	Part No.	Description	部 品 名	Remarks	Common Model	Markets
	FG 21: 21: 80	Ceramic Cap	180pF 50V	セラコン	C521,522	
	FG 41: 21: 20	"	120pF 50V	"	C467,468,471,472	
	FG 41: 22: 70	"	270pF 50V	"	C407,408,427,428	
	FG 41: 23: 30	"	330pF 50V	"	C401~406	G
	FG 41: 24: 70	"	470pF 50V	"	C443,444	
	FG 41: 25: 60	"	560pF 50V	"	C451,452	
	FG 41: 31: 00	"	1000pF 50V	"	C447,448	
	FG 41: 32: 20	"	2200pF 50V	"	C473,475	
	FG 44: 42: 20	"	0.022 $\mu$ F 50V	"	C496,504,511,512	
	FG 44: 42: 20	"	0.022 $\mu$ F 50V	"	C513,514,529,531,533,535	G
	FZ 00: 35: 80	Electrolytic Cap.	47000 $\mu$ F 5.5V	ケミコン	C491	
※	FZ 00: 41: 20	"	8500 $\mu$ F 51V	"	C509,510	} Inter-changeable
※	FZ 00: 41: 40	"	8500 $\mu$ F 55V	"	"	
	FA 15: 33: 00	Mylar Cap.	3000pF 50V	マイラーコン	C434,437	
	UA 25: 32: 70	"	2700pF 50V	"	C413,414	
	UA 25: 34: 70	"	4700pF 50V	"	C435	
	UA 25: 41: 00	"	0.01 $\mu$ F 50V	"	C423,424	
	UA 25: 31: 50	"	1500pF 50V	"	C419,420	
	UA 25: 42: 20	"	0.022 $\mu$ F 50V	"	C429~432,477~480, 525~528	
	UA 25: 45: 60	"	0.056 $\mu$ F 50V	"	C538	
	UA 25: 46: 80	"	0.068 $\mu$ F 50V	"	C425,426	
	FA 15: 47: 50	"	0.075 $\mu$ F 50V	"	C421,422	
	UA 25: 43: 30	"	0.033 $\mu$ F 50V	"	C465,466,474	
	UA 25: 51: 00	"	0.1 $\mu$ F 50V	"	C417,418,483~486	
	UA 25: 51: 50	"	0.15 $\mu$ F 50V	"	C433,436	
	FA 15: 54: 70	"	0.47 $\mu$ F 50V	"	C415,416	
	UW 91: 74: 70	Electrolytic Cap.	47 $\mu$ F 6.3V	ケミコン	C498	
	UW 91: 81: 00	"	100 $\mu$ F 6.3V	"	C455,456,489,497	
	UW 91: 84: 70	"	470 $\mu$ F 6.3V	"	C495	
	UW 82: 92: 20	"	2200 $\mu$ F 10V	"	C494	
	UW 92: 72: 20	"	22 $\mu$ F 10V	"	C492	
	UW 93: 81: 00	"	100 $\mu$ F 16V	"	C487,488	
	UW 94: 64: 70	"	4.7 $\mu$ F 25V	"	C438,440	
	UW 94: 71: 00	"	10 $\mu$ F 25V	"	C439,499,500	
	UW 94: 74: 70	"	47 $\mu$ F 25V	"	C411,412,441,442	
	UW 94: 81: 00	"	100 $\mu$ F 25V	"	C507,508,523,524	
	UW 94: 83: 30	"	330 $\mu$ F 25V	"	C505,506	
	UW 94: 92: 20	"	2200 $\mu$ F 25V	"	C501	
	UW 96: 54: 70	"	0.47 $\mu$ F 50V	"	C493	
	UW 96: 61: 00	"	1 $\mu$ F 50V	"	C449,450,515~518	
	UW 96: 64: 70	"	4.7 $\mu$ F 50V	"	C459,460	
	UW 96: 71: 00	"	10 $\mu$ F 50V	"	C463,464,469,470,481,482	
	UW 86: 81: 00	"	100 $\mu$ F 50V	"	C461,462	
	GD 90: 03: 40	Output Coil	1.5 $\mu$ H	アウトプットコイル	L401,402	
※	HF 85: 51: 00	Carbon Resistor	100 $\Omega$ 1/6W	カーボン抵抗	R425,426,601,602	
※	HF 85: 52: 20	"	220 $\Omega$ "	"	R401~406	R,U,A,C,B LR
※	HF 85: 62: 20	"	2.2k $\Omega$ "	"	"	G
※	HF 85: 52: 70	"	270 $\Omega$ "	"	R582	
※	HF 85: 55: 60	"	560 $\Omega$ "	"	R429,430,515~518	
※	HF 85: 61: 00	"	1k $\Omega$ "	"	R417,418,481,482	
※	HF 85: 61: 20	"	1.2k $\Omega$ "	"	R455,456	

※ New Parts (新規部品)

Ref. No.	Part No.				Description	部 品 名	Remarks	Common Model	Markets
※	HF	85	63	30	Carbon Resistor	3.3kΩ 1/6W	カーボン抵抗	R421,422,611,612	
	HF	85	63	90	"	3.9kΩ "	"	R473~476,477,478,495,496	
※	HF	85	64	70	"	4.7kΩ "	"	R407~409,451,452,463~466	
※	HF	85	65	60	"	5.6kΩ "	"	R575	
※	HF	85	66	80	"	6.8kΩ "	"	R445,446,470,471	
※	HF	85	68	20	"	8.2kΩ "	"	R431,432,599,600	
※	HF	85	71	00	"	10kΩ "	"	R427,428,439~442,453,454,566~568,573,574	
※	HF	85	71	20	"	12kΩ "	"	R423,424	
※	HF	85	71	50	"	15kΩ "	"	R467,468	
※	HF	85	76	80	"	68kΩ "	"	R589,590	
※	HF	85	73	30	"	33kΩ "	"	R457,458	
※	HF	85	81	00	"	100kΩ "	"	R419,420,469,480,535~538,563,572,576~579,609,610	
※	HF	85	81	20	"	120kΩ "	"	R411~416	
※	HF	85	82	70	"	270kΩ "	"	R603,604	
※	HF	85	83	90	"	390kΩ "	"	R459,460,584	
	HL	71	34	70	Metal Oxide Film Resistor	4.7Ω 1P	酸 金 抵 抗	R527~530	
	HL	31	64	70	"	4.7kΩ 1P	"	R493,494	△
	HL	32	52	20	"	220Ω 2P	"	R531,532	
	HU	07	62	00	Metal Film Resistor	2kΩ RE35	金 属 被 膜 抵 抗	R607,608	
※	HQ	42	02	80	Slide Variable Resistor	B5kΩ	ス ラ イ ド V R	VR402 SPATIAL EXPANDER	
※	HS	31	20	80	Variable Resistor		可 変 抵 抗 器	VR401 VOLUME BALANCE	
※	HW	59	34	70	Fuse Resistor	4.7Ω 1/4W	ヒ ュ ー ズ 抵 抗	FR401~403	△
※	HW	59	51	00	"	100Ω 1/4W	"	FR404~407	△
	iA	07	77	00	Transistor	2SA777	ト ラ ン ジ ス タ	TR405~407	
	iA	09	99	10	"	2SA999(E,F)	"	TR408~419 423,428	} Inter-changeable
	iA	11	27	00	"	2SA1127(R,S,T)	"	"	
	iB	05	07	00	"	2B507	"	TR432	△
	iC	09	82	00	"	2SC982	"	TR433	△
	iC	15	09	00	"	2SC1509(P,Q,R,S)	"	TR403,404	
	iC	19	83	00	"	2SC1983	"	TR429,430	
	iC	23	20	10	"	2SC2320(E,F)	"	TR420~422 424,426,427	} Inter-changeable
	iC	26	34	00	"	2SC2634(R,S,T)	"	"	
	iC	28	78	00	"	2SC2878	"	TR401,402	
	iD	03	13	00	"	2SD313(E,F)	"	TR431	△
	iD	04	00	20	"	2SD400(F)	"	TR425	
	iG	05	82	00	IC	M5218L	I	C	IC406,411,412
	iG	08	92	00	"	LC4066B	"	"	} Inter-changeable
	iG	06	16	00	"	μPD4066BC	"	"	
※	iG	09	16	00	"	STK2250Y	"	IC414	△
※	iG	09	20	00	"	M5220L	"	IC405	
※	iG	09	24	00	"	STK3061Y	"	IC413	
※	iG	09	26	00	"	LC6505C-612	"	IC415	
	iF	00	00	40	Diode	1S1555	ダ イ オ ー ド	D417~430, 437	} Inter-changeable
	iF	00	06	70	"	1S2473	"	"	
	iF	00	13	80	"	1SS84	"	D401~412	
	iF	00	34	40	Zener Diode	RD6.2EB3	ツ ェ ナ ー ダ イ オ ー ド	D432	
	iF	00	25	50	"	HZ9A-1	"	D415,416	
	iF	00	23	50	"	HZ12B2	"	D431	

※ New Parts (新規部品)



Ref. No.	Part No.	Description	部 品 名	Remarks	Common Model	Markets
	iF 00 30 40	Zener Diode	HZ18-1L	ツェナーダイオード	D413,414,435,436	
	iH 00 07 70	Diode Bridge	S1RBA	ダイオードブリッジ	D433	
	iH 00 08 70	"	4D4B41	"	D434	Inter-changeable
	iH 00 10 40	"	RB402(LFD)	"	"	
	iH 00 10 90	"	S4VB20	"	"	
*	KA 80 37 90	Push Switch	2 circuit	プッシュスイッチ	SW401	
	KA 90 29 30	Switch		タクトスイッチ	SW402~404	DOWN-UP, MEMORY
	KC 00 11 00	Relay	DC12V	リ レ	RY401	R,A,G,B
*	KC 00 14 90	"	"	"	"	U,C,LR
	LB 20 22 70	Pin Jack	2P	ピンジャック	PJ401	
	LB 40 10 30	"	4P	"	PJ402,403	
	LB 30 17 50	Headphone Jack		ヘッドホンジャック	JK401	
	LA 00 23 40	Wrapping Terminal	P=7.5 5P i-Type	i型ラッピング端子板		
*	LA 00 44 80	Speaker Terminal	8P	スピーカーターミナル		G
	LA 00 34 30	"	8P	"		R,U,A,C,B,LR
	LB 91 20 50	Short Plug	5P i-Type	ショートプラグ		
*	LB 92 11 00	Connector Plug	10P i-Type	コネクタープラグ		
*	LB 92 11 10	"	11P i-Type	"		
	BA 08 71 30	Radiation Block		放 熱 ブ ロ ッ ク		
	CB 06 88 80	Plastic Rivet		プラスチックリベット		
	BA 08 40 00	Heat Sink		放 熱 板		
	BB 06 83 70	Ground Plate		ア ー ス 金 具		
	Ei 33 00 66	Birding Head Tapping Screw	3×8 FCM3-Bz	バインドタッピングネジ	PACK	
	Ei 33 01 46	"	3×14 FCM3-Bz	"	PACK	

\* New Parts (新規部品)

Ref. No.	Part No.	Description	部 品 名	Remarks	Common Model	Markets
*	PB 06 28 20	Keyboard Unit	キーボードユニット			
	KA 80 29 50	Switch	タクトスイッチ			
	HV 45 71 00	Flame Proof Carbon Resistor	10kΩ 1/4W	不燃化カーボン抵抗		
	HV 35 61 00	"	1kΩ "	"		
	HV 35 53 90	"	390Ω "	"		
	HV 35 46 80	"	68Ω "	"		
	UW 86 62 20	Electrolytic Cap.	2.2μF 50V	ケ ミ コ ン		
	iF 00 00 40	Diode	1S1555	ダイオード		
	iA 09 37 00	Transistor	2SA937	トランジスタ		
	iG 04 68 00	IC	BA6104	I C		
		"	M54527P	"	} Replaced by IC : LB1274 } Interchangeable	
	iG 04 94 00	"	LB1274	"		
	iG 03 11 00	"	M54516P	"		
*	iX 60 14 70	"	M54560P	"		
*	iF 00 44 10	Frequency Display	LC-205MK(N)	周波数表示器		
*	iF 00 45 40	LED (LED)	SLR-34URC3H	L E D		
*	iF 00 42 70	" (LED)	SLR-55URC3H	"		
*	iF 00 45 50	" (Green)	SLR-34MC3H	"		
*	iX 60 14 80	LED Unit	SEL9501E	5 連 LED ユニット	SIGNAL Q	
*	iF 00 44 00	"	LS-050	CCSS LED ユニット	CCSS	

\* New Parts (新規部品)



## MECHANISM PARTS

Ref. No.	Part No.	Description	部 品 名	Remarks	Common Model	Markets
* 1	NB 61 23 40	Front Panel Unit	パネルユニット			
* "	NB 61 23 50	"	"	R-70M		LR
* 1-1	PB 06 28 20	Keyboard Unit	キーボードユニット			
* 1-2	CB 61 82 40	Button	シーソーボタン			
* 1-3	CB 61 82 50	"	シングルボタン			
* 1-4	CB 06 88 80	Plastic Rivet	プラスチックリベット			
* 1-5	ED 03 00 66	Binding Head Screw	3×6 ZMC2-Y	バインド小ネジ		
* 1-6	CB 07 41 90	Adhesive Tape	ダブルタックテープ			
* 2	GA 66 45 00	Power Transformer	電源トランス			U,C
* "	GA 66 47 00	"	"			G
* "	GA 66 48 00	"	"			A,B
* "	GA 66 46 00	"	"			R,LR
* 3	LB 20 14 80	Voltage Selector	電圧切換器			R,LR
* 4	CB 07 27 50	Cord Stopper	SR-4N-4	コードストッパー		
* 5	HG 30 92 20	Carbon Resistor	2.2MΩ 1/2P	カーボン抵抗		U,C,LR
* 6	LA 00 29 50	Terminal Board	2P	中継端子台		A,G,B
* 7	LB 20 13 00	Fuse Holder		ヒューズホルダー		R,U,C,LR
* "	LB 20 21 10	"		"		G,B,A
* 8	LB 60 48 10	AC Outlet	M7026-B	ACアウトレット		R,U,C,LR
* 9	MG 00 07 80	Power Cord	6A250V 2m	電源コード		R
* "	MG 00 09 20	"	7.5A250V 2.5m	"		A
* "	MG 00 09 50	"	2.5A250V 2m	"		G
* "	MG 00 10 00	"	6A300/500V 2m	"		B
* "	MG 00 14 50	"	10A125V 1.98m	"	Inter-	U,C,LR
* "	MG 00 14 60	"	10A125V 2m	"	Changeable	U,C,LR
* 10	CB 06 88 80	Plastic Rivet		プラスチックリベット		
* 11	LA 00 44 30	Terminal Plate		ラグ端子板		U,C,LR
* 12	Ei 33 00 86	Binding Head Tapping Screw	3×8 FCM3-B $\ell$	バインドタッピングネジ	PACK	
* 13	ED 33 00 66	Binding Head Screw	3×6 FCM3-B $\ell$	バインド小ネジ	PACK	
* 14	ED 34 00 66	"	4×6 FCM3-B $\ell$	"	PACK	
* 15	EV 20 30 46	Plain Washer	$\phi$ 4 FCM3-B $\ell$	平座金	PACK	
* 16	Ei 33 01 06	Binding Head Tapping Screw	3×10 ZMC2-B $\ell$	バインドタッピングネジ	PACK	
* 17	NA 08 17 80	Tuner Circuit Board		チューナーシート		R,LR
* "	NA 08 17 90	"		"		U,C
* "	NA 08 18 00	"		"		A,B
* "	NA 08 18 10	"		"		G
* 18	NA 08 19 00	Main Circuit Board		メインシート		R,A,B
* "	NA 08 19 10	"		"		U,C,LR
* "	NA 08 19 20	"		"		G
* 19	KA 80 24 60	Push Switch	4A/128A	プッシュスイッチ	POWER	A,G,B
* "	KA 80 25 50	"	TV-8	"	"	R,U,C,LR
* 20	Fi 38 41 00	Ceramic Cap.	0.01 $\mu$ F	セラコン		
* 21	CB 09 52 60	Cover		コンデンサーカバー		
* 22	KA 90 34 70	Remote Push Switch		リモートプッシュスイッチ	PHONO Selector	
* 23	KB 00 04 00	Fuse	T5.0A 250V	ヒューズ		R
* "	KB 00 13 30	"	T2.0A 250V	"		G,B,A
* "	KB 00 25 90	"	5.0A 250V	"		U,C,LR
* 24	KB 00 04 20	"	T2.5A 250V	"		R
* "	KB 00 25 80	"	2.5A 250V	"		LR
* 25	KB 00 03 50	"	T2.0A 250V	"		R
* "	KB 00 07 20	"	T800mA 250V	"		G,B,A
* "	KB 00 10 30	"	2.0A 250V	"		U,C,LR

\* New Parts (新規部品)

Ref. No.	Part No.	Description	部 品 名	Remarks	Common Model	Markets
* 26	AA 61 65 00	Top Cover	トップカバー			
* 27	AA 61 65 40	Bottom Cover	ボトムカバー			
* 28	AA 61 65 60	Rear Panel	リアパネル			R
* "	AA 61 65 70	"	"			U,C
* "	AA 61 65 80	"	"			G
* "	AA 61 65 90	"	"			A,B
* "	AA 61 72 10	"	"	R-70M		LR
* 29	BA 08 58 50	Heat Sink	ヒートキッカー			
* 30	BA 08 57 90	Knob	ツマミ	VOLUME		
* 31	BA 08 58 00	"	"	BALANCE		
* 32	CB 61 82 60	Side Cover	サイドカバー			
* 33	CB 61 82 80	Slide Knob	スライドツマミ	SPATIAL EXPANDER		
* 34	CB 61 03 90	Leg	脚			K-200
* 35	CB 61 01 30	Push Button	プッシュボタン	SPEAKERS PHONO		"
* 36	CB 09 43 60	Spacer	プリントスペーサー			A-550
* 37	CB 60 74 70	Antenna Holder	アンテナホルダー			T-10
* 38	CB 61 84 90	Plastic Rivet	プラスチックリベット			
* 39	EZ 00 14 00	Ground Terminal Screw	3×13.5 MFNI-II	アース端子ネジ		
* 40	EV 90 13 60	Sens Plain Washer	$\phi$ 10× $\phi$ 3.6×t0.8 FNM3-3g	セムス平座金		
* 41	ED 32 60 46	Binding Head Screw	2.6×4 FCM3-B $\ell$	バインド小ネジ	PACK	R,LR
* 42	EZ 00 13 10	Cup Screw	4×8 FNM3-3g	カップタイトネジ		
* 43	EA 32 00 36	Pan Head Screw	2×3 FCM3-B $\ell$	ナベ小ネジ	PACK	
* 44	CB 61 99 90	Rubber, Antivibration		防振ゴム		
* 45	KA 90 53 60	Remote Switch Wire Part		リモートSWワイヤー部	PHONO	
* 46	CB 62 01 00	Rubber, Antivibration		防振ゴム		
* 47	CB 62 01 50	"		"		
* 48	AA 61 67 00	Antenna Panel	アンテナパネル			U,A,G,C,B
* "	AA 61 83 20	"	"			R,L,R
* 49	EN 30 00 16	Bind Bonding Head Tapping Screw	3×8 FCM3-B $\ell$	バインドボンディング タッピングネジ	PACK	
* 50	EZ 00 13 50	Cup Screw	3×14 FCM3-B $\ell$	カップスクリュー(Bタイト)		
	CB 06 92 50	Binding Tie	BK-1	インシュロックタイ		
		Accessories Assembly	付属品 Ass'y			
	Mi 08 28 50	Antenna	FM	FM Q マッチアンテナ		
	Mi 08 29 10	Loop Antenna	AM	ループアンテナ		

\* New Parts (新規部品)

EXPLODED VIEW (Keyboard Unit)

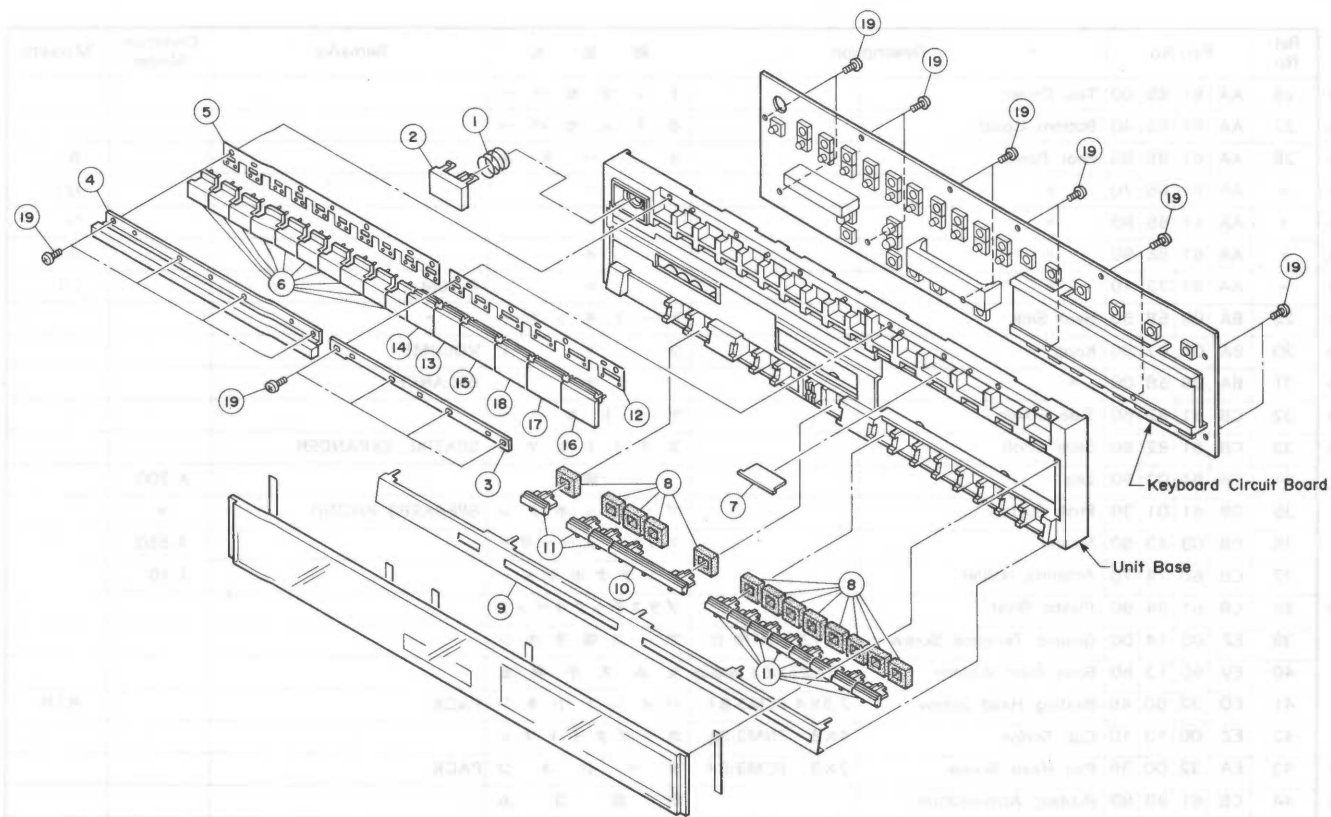

MECHANISM PARTS (Keyboard Unit)

Ref. No.	Part No.	Description	部品名	Remarks	Common Model	Markets
*	PB 06:28:20	Keyboard Unit	キーボードユニット			
*	1 AX 60:00:40	Spring	スプリング	SUS304WPB		
*	2 CB 61:73:20	Button	ボタン		POWER	
*	3 AX 60:00:70	Spring, Hold	バネ押え	t1.6		
*	4 CB 61:75:20	Button Blow	ボタンブロー		PRESET	
*	5 AX 60:00:60	Spring, Button	ボタンバネ		"	
*	6 CB 61:73:40	Button	ボタン		"	
*	7 CX 60:00:90	Stopper	ストッパー	SPCC-SD t-0.8		
*	8 CX 60:01:00	Cushion	クッション	t6		
*	9 CX 60:01:10	Sub Panel	サブパネル			
*	10 CB 61:73:60	Button	ボタン		TUNING	
*	11 CB 61:73:70	Push Button	プッシュボタン			
*	12 AX 60:00:80	Spring, Button	ボタンバネ	SUS304-CSP-H	INPUT	
*	13 CB 61:74:70	Button	ボタン		TAPE MONI 2	
*	14 CB 61:74:60	"	"		TAPE MONI 1	
*	15 CB 61:75:80	"	"		Blank	
*	16 CB 61:75:40	"	"		TUNER	
*	17 CB 61:75:50	"	"		VIDEO / AUX	
*	18 CB 61:75:60	"	"		PHONO	
*	19 EA 02:60:66	Pan Head Tapping Screw	ナベタッピングネジ	M2.6×6 ZMC-2Y	PACK	

\* New Parts (新規部品)

R-70/R-70M

YAMAHA